

Guide to the Changes to Seat Belt Installations

INTRODUCTION

The purpose of this document is to provide advice to vehicle builders and converters and equipment manufacturers on changes to the requirements to fit seat belts to new buses, coaches and minibuses (including van conversions) and to the strength requirements of the anchorages. The changes were contained in an amendment to the Construction and Use Regulations that came into force on 1st October 2001. This document contains details of the checks that will be made where necessary on the installations to ensure compliance with the strength requirements.

The Vehicle Inspectorate gratefully acknowledges the help provided by STATUS, Manchester Metropolitan University, Manchester M1 5GD in the preparation of this document and the photographs on the cover.

It is important to note that for those vehicles shown in the table below, first used on or after 1st October 2001, the current installation check (normally carried out at Certification or first annual test) will apply only till 31st October 2002. From 1st November 2002 see '**Interim Requirements**' section.

Details of mandatory fitting requirements for buses, coaches and minibuses first used on or after 1st October 2001

Vehicles affected	Restraints Required
Buses with a gross weight exceeding 3,500kg (including minibuses and coaches) which are first used on or after 1st October 2001 (except those designed for urban use with standing passengers, or those manufactured 6 months before that date).	Inertia reel 3-point seat belts or retractable lap belts in all forward and rearward facing seats. Lap belts may only be fitted in forward facing non-exposed seats where an appropriate energy absorbing seat or surface is present in front. Lap belts may be fitted on any exposed seat where there are no seats or surfaces directly in front. (Alternatively, disabled persons seat belts, or child restraints, may be fitted.)
Buses with a gross weight not exceeding 3,500kg (including minibuses) which are first used on or after 1st October 2001 (except those designed for urban use with standing passengers, or those manufactured 6 months before that date).	Inertia reel 3-point seat belts in forward facing seats. Inertia reel 3-point seat belts or retractable lap belts in rearwards facing seats. (Alternatively, disabled persons seat belts, or child restraints, may be fitted.)

It will be noted from the table that the only vehicles first used on or after 1st October 2001 that do not require mandatory seat belts fitted are vehicles designed for urban use with standing passengers.

Date of manufacture.

The requirements will apply to those vehicles manufactured on or after 1st April 2001 and first used on or after 1st October 2001. This means that a vehicle first used on or after 1st October 2001 will not have to meet the requirements if it was manufactured before 1st April 2001.

It has been agreed that the date of manufacture can be taken to be the date when two major components are put together. This could be for example an engine fitted on a chassis and not necessarily a body on a chassis. A manufacturer who claims that a vehicle does not currently fall within the scope of the regulations because of the date of manufacture will need to provide written evidence.

Prison vehicles.

Vehicles constructed or adapted for the secure transport of prisoners are required to be fitted with seat belts for the driver's and any front passenger's seat. Other forward or rearward facing seats in these vehicles are required to be fitted with anchorage points so that seat belts can be installed if required.

Reasons for Change.

The changes to the Construction and Use regulations require seat belt mountings to conform to the requirements of certain EEC Directives, (these are covered in other sections), this would involve manufacturers in gaining proof that their installations meet the strength requirements contained in the Directive (normally gained by 'Pull Testing'). The current installation check does not relate directly to the strength requirements in the Directives and therefore can no longer be used for these vehicles.

Legislation currently only allows the checking at annual MOT (Class 4 or 5) test of additional seat belts fitted in addition to those necessary to comply with the law. The new legislation has made the installation of most seat belts mandatory, and hence the installation will not therefore be checked in the annual MOT (Class 4 or 5) test for most vehicles that entered service after 1st October 2001.

Scope of Inspections from 1st November 2002.

Public service vehicles first used on or after 1st October 2001 requiring a Certificate of Initial Fitness, will be inspected at Certification to the new requirements including proof (i.e. Pull test reports covering the specific type of installation) for the strength of the seat belt mountings.

Following consultation it became apparent that some manufacturers needed more time to obtain proof via 'Pull Test' that their seat belt installations met the strength requirements of the Directive. To allow time where required for tests to be conducted, an interim arrangement including a new Enhanced Visual Inspection has been developed. The basis of the advice is a combination of calculations, real-life testing and 'pull tests' carried out on representative structures. It must be stressed that these requirements are over engineered to provide a degree of confidence that installations would meet the requirements of the Directive. Use of the visual check approach will probably mean a penalty in weight, and materials against other designs that have been successfully tested to the Directive requirements.

For private minibuses, buses and coaches tested as Class 4 or 5 vehicles under the MOT testing scheme, the seat belt installations will, in the majority of cases, be required to comply with the law. Because such installations are mandatory it will mean that the installation will no longer be inspected at first annual test for the vehicle. For these vehicles a voluntary check of the installation is available from the Vehicle Inspectorate, except where a pull test has been conducted. The standards for this inspection are identical to the Enhanced Visual Inspection for certified public service vehicles as described in Appendix 1.

Interim Requirements for Public Service Vehicles (1st October 2002 until 31st July 2004)

These will apply from 1st November 2002 until 31st July 2004, at this point they will be reviewed, to take account of any changes that may be required due to the recently released Bus Directive, and any associated legal changes.

These interim requirements are to allow time for manufacturers to gain 'Pull Test' certificates for the seat/seat belt anchorage, as outlined in the 'Anchorage Requirements' section.

The interim requirements will only be an option on vehicles that have seat belts attached to seats tested to the approved requirements of M2 or M3 as required, and where the installation of the seat to floor anchorage can be visually checked. In all other cases a certified 'Pull Test' report for the particular seat/seat belt and floor anchorages will be required.

NB: M2 = Buses having a maximum gross weight not exceeding 5000 kg, M3 = Buses having a maximum gross weight exceeding 5000 kg.

Where an anchorage system cannot be visually inspected at Certification, the Certifying Officer may require an inspection of the anchorages before the remaining panels etc are fitted prior to the completion of the certification examination. The Certifying Officer would have to bear in mind the time/financial elements of using this option. If the Certifying Officer is satisfied with the design, i.e. that the strength of the anchorages is borne by part of the structure and not an add-on plate, he may decide not to inspect remaining vehicles in the batch. However, declarations from the manufacturer to this effect will be required.

The criteria for the Enhanced Visual Check are set out in annex 1. Readers of this document should note that Certifying Officers have been strongly advised to reject installations that depart from the criteria set out in Appendix 1, except where component dimensions have been increased.

Criteria to be met with both the Interim and Full checks

Seat belt markings and approvals.

Apart from those specifically designed for disabled persons the following markings and approval standards apply to all seat belts:

- a BS kitemark and approved to BS3254 Part 1
- or
- an "E" mark and approved to ECE regulation 16.04
- or
- an "e" mark and approved to Community Directive 77/541 (as amended by 96/36 or 2000/3)

Evidence of compliance at certification.

If a seat belt is not marked with one of the above then documentary evidence of compliance, which clearly identifies the seat belts in question, will be required.

or

If identification is not visible in the installed state then one may need to be dismantled to the extent required to confirm compliance.

Seats and other features.

For the purposes of the **Interim Requirements** the presenter will have to produce documentation, (the documentation would have to be clear enough to identify that the certificates cover the seats being presented, this may mean in some circumstances, the seats have to bear an identification mark or number) that the seat and seat legs/base meet and have been tested to either M2 or M3 standard independently of the vehicle being examined.

For the full requirement the 'Pull Test' documentation would have to cover the particular seat and leg/base and floor being presented for inspection.

Energy Absorbing Surfaces

This applies to buses exceeding 3500kg fitted with retractable lap belts on forward facing seats. Any feature which falls directly in front of a seat contained in the reference zone will need to be

energy absorbent. Lap belts may only be fitted in forward facing non exposed seats (including the driver's seat) where any seat or surface in front which falls within the reference zone meets the appropriate energy absorbing criteria. Lap belts **may** be fitted on any exposed seat where there are no seats or surfaces directly in front.

The following note is to provide a practical interpretation of paragraph 3.1.10 of Annex 1 of Directive 96/36 which allows a lap belt under the following conditions:-:

[1] There is a seat or other vehicle parts conforming to paragraph 3.5 of Appendix 1 of Annex III of Directive 74/408/EEC directly in front, or

[2]-no part of the vehicle is in or, when the vehicle is in motion, capable of being in the reference zone (see below), or

[3]- parts of the vehicle within the said reference zone comply with the energy absorbing requirements set out in Appendix 6 of Annex III of Directive 74/408/EEC. '

The reference zone (see Appendix 2)

This is defined as: the space between two vertical longitudinal planes, 400mm apart and symmetrical with respect to the H point (hip point), and defined by the rotation of the apparatus described in Directive 96/36/EEC from vertical to a position where the head is tangential to a horizontal plane situated 25.4 mm above the H point. The apparatus shall be positioned as described in that annex and set to the maximum length of 840mm'

Essentially this describes the 'lollipop test' which is used to determine the surfaces that can be contacted by an apparatus representing a head and upper torso hinged around the hip point, as if restrained by a lap belt.

The agreed interpretation is that everything within the arc defined by the movement of the pendulum from vertical to horizontal position 25.4mm above the 'H' (hip) point, would be in the reference zone. The logic for this approach is that, with the pendulum set at its maximum length it may in certain cases strike or overlap the top of the seat in front (thus implying that the seat back is 'safe' because a head would be unlikely to strike it) in reality, shorter people (such as children) could well strike their heads on the seat back or other object in the reference zone.

Any seat which has nothing in the reference zone (and therefore meets **condition [2]** above) can be fitted with a lap belt. If there is a seat back or other surface in the reference zone, then either condition [1] or condition [3] should be met if a lap belt is to be permitted.

Condition [1] This refers to a particular type of approval under the seating Directive 74/408 or the equivalent ECE Regulation 80. When a seat (or other component) is approved to these requirements there are normally two dynamic tests undertaken; test 1 and test 2. Test 1 represents the situation with an unrestrained occupant seated behind the test seat and test 2 represents the situation with a restrained occupant behind the test seat. To confirm that a seat meets the requirements of this condition, a Certifying Officer will want to see a type approval certificate to 74/408 (as amended by 96/37) or ECE Regulation 80, with confirmation that test 2 has been carried out.

Condition [3] This refers to Appendix 6 of Annex III to 74/408 which in turn refers to the energy-absorbing requirements contained in Directive 74/60 or the equivalent ECE Regulation 21. Similar requirements are contained in Annex II to 74/408 or the equivalent ECE Regulation 17. The test procedure involves a pendulum with an instrumented headform, which is struck against the test surface at a velocity of 24.1 km/hr. The resultant headform deceleration should not exceed 80g continuously for more than 3 milliseconds. Type approval certificates to these standards should be sufficient to confirm compliance with respect to seat backs or other components in the reference zone. Alternatively 'self certification' could be considered (e.g., written confirmation from a seat manufacturer or trim manufacturer that the component meets the test requirements even if it has not been formally certified.)

Failure to meet any of the above conditions would mean that a 3-point belt would need to be fitted.

Appendix 3 shows an example of the type of apparatus used when assessing the reference zone. We have based the dimensions of the base plate and attachment on a practical interpretation of the requirements of the Directive. Some approved apparatus may differ from this.

Evidence of compliance at certification.

Evidence that the lap belt has been installed in compliance with paragraph 3.1.10 of Annex I to Community Directive 96/36 or 2000/3.

Requirements for vehicles certified after 31st July 2004 or where the Enhanced Visual Check has not been used.

Seat belt anchorages on forward and rearward facing seats.

Seat belt anchorages may be attached directly to the vehicle structure, to tracking or mounts attached to the vehicle structure or to the seat structure.

Seat belt anchorages must be tested to the following standards set out in :

- ECE Regulation 14.04 or 14.05
- or**
- EU Directive 76/115 (as amended by 96/38)

Anchorage loads (the load is applied through the belt in the direction the seat is facing - anchorages must withstand the load for not less than 0.2 seconds)			
	M2 Vehicles (forward facing seats)	M3 Vehicles (forward facing seats)	M2, M3 Vehicles (rear facing seats)
Lap belt	11.1 kN	7.4 kN	7.4 kN
Lap & diagonal belt:			
Lap section	6.75 kN	4.5 kN	4.5 kN
Diagonal section	6.75 kN	4.5 kN	4.5 kN
(both sections are tested simultaneously)			
Additional forward load per seat (integral seat belts only)	10 times the weight of the complete seat	6.6 times the weight of the complete seat	6.6 times the weight of the complete seat

M2 = Buses having a maximum gross weight not exceeding 5,000 kg

M3 = Buses having a maximum gross weight exceeding 5,000 kg

Evidence of compliance at Inspection.

Although anchorage type-approval is not mandatory for the classes of vehicle covered by these new regulations, the manufacturer or converter has a responsibility to ensure that all seat belt anchorages comply with the above standards. The only definite way of establishing whether a seat belt anchorage design meets the legislative requirements is to have it pull-tested. Manufacturers who are producing a number of vehicles of standard design will be able to assess their proposed anchorages by pull-testing either a complete vehicle prototype, or an assembly of key components representative of the vehicles structure.

The currently used installation check is not acceptable evidence of compliance. The following evidence that tests have been conducted will be required:

Full type approval to one of the prescribed directives or ECE regulations, or a letter of compliance issued by VCA (Vehicle Certification Agency).

or

Test reports on an identical vehicle or structure to the vehicle requiring certification.

or

Test results on a representative vehicle or structure which whilst not identical is similar and there is a high degree of confidence that they can be applied to the vehicle requiring certification.

Please note the following:

- 1) All the main elements of the anchorage from the belt fixing to the structure of the vehicle must be covered by evidence of testing to the approval standard in a document which clearly identifies all the elements in the design that was subject to the load test.
- 2) Where seats tested to Community Directive 76/115/EC as amended up to and including 96/38 are fitted, additional test information will be required to cover the anchorage of the seats to the vehicle structure.
- 3) Evidence of every type of mounting utilised on any given vehicle will need to be clearly identified.
- 4) Information for seats, the vehicle structure and any connecting components must clearly indicate if they are for 2 or 3 point seat belts.
- 5) Information for seat mountings on a vehicle or vehicle sub- system must be supplemented by the strength details specific to each of the seat types which may be attached to it.
- 6) Vehicles must generally be built to an identical specification and standard as the vehicle or component tested. However, systems which vary from the tested configuration will be acceptable provided the testing organisation provides a written statement to the effect that the system present on the vehicle is considered to be at least as strong as the system tested.
- 7) The Vehicle Inspectorate reserves the right to witness any pull test, however if the test is being witnessed by VCA (Vehicle Certification Agency) to the full technical and installation requirements of the Directive, then this option would not be taken up.

Additional Seat belts fitted voluntarily after 1st October 2001 to a Public Service Vehicle used under a Certificate of Initial Fitness.

Until 31st October 2002 the current installation check applies.

From 1st November 2002 there will be two types of check, these are:

- 1) Vehicles that were first used before 1st October 2001, and have additional seat belts fitted, will be inspected by a Certifying Officer to ensure the alteration meets the requirements. At the next annual psv test, the installation will be formally signed off using the current installation check criteria.
- 2) For vehicles first used on or after 1st October 2001 and subsequently have seat belts fitted voluntarily after 1 November 2002 will be inspected by a Certifying Officer who will check that the anchorage points comply with the technical and installation requirements of:
Community Directive 76/115, 81/575, 82/318, 90/629 or 96/38
or
ECE regulation 14, 14.01, 14.02, 14.03, 14,04 or 14.05.
or
Meet the requirements of the Enhanced Visual Inspection (see Appendix 1) and, if lap belts are fitted to forward facing seats, meet the padding requirements contained in the current seat belt installation check.

Note: For both types of check a Notifiable Alteration form (VTP5 available from Vehicle Inspectorate test stations) should be submitted to:

Vehicle Inspectorate
PSV Centre
Welcombe House,
91/92 The Strand,
Swansea.
SA1 2DA.

Additional Seat belts fitted voluntarily after 1st October 2001 to a private minibus, bus or coach falling under the Class 4 or Class 5 MOT testing scheme.

These will need to meet the technical and installation requirements of:

Community Directive 76/115, 81/575, 82/318, 90/629 or 96/38

or

ECE regulation 14, 14.01, 14.02, 14.03, 14,04 or 14.05.

Mandatory seat belts on private minibuses, buses or coaches falling under the class 4 or class 5 first used on or after 01st October 2001

There will not be a check on these mandatory belts at the first MOT test for these vehicles. From 1st November 2002, a voluntary check service is available from the Vehicle Inspectorate for those installations that have not been subjected to a “pull” test. The voluntary check will ensure it meets the requirements in Appendix 1.

Appendix 1

This inspection was developed to allow a period of time for manufacturers of vehicles to conduct a pull test and does not remove their responsibility to comply in full with the requirements of the Road Vehicles Construction and Use Regulations. As a temporary alternative to the “pull test”, it is applicable only until July 2004 when the situation is to be reviewed. It has been developed using information taken from various similar “pull tests” to give a size/type of mounting that as far as can be assessed would meet M2 or M3 standards. However it should be noted that there can be no guarantee that these mountings would successfully pass a “pull test” in all vehicles. To be able to use this alternative, the Certifying Officer must be satisfied he can see sufficient of the structure/mountings to assess them against the following criteria. If a vehicle does not match the minimum criteria in this document then a “pull test” or documented evidence of such a test, from a test house is required, before a decision can be made on any deviation.

Note: These guidance notes do not cover seat belts installed on the upper deck of a double deck vehicle, or a seat belt attached to the structure of the vehicle. These installations would require a pull test to demonstrate compliance with the requirements.

General Requirements for all Vehicles

1. Seats with integral belt anchorages must be accompanied by certification to show that they are capable of meeting in full the Directive requirements independently of the vehicle.
2. The strength of belt anchorages secured to the vehicle and not to a seat, will be not be included in this examination. Certification that the installation meets the requirements of the Directive will be required.
3. Where seats are attached to tracking, certification for the tracking **and the associated lockable fitting (s)**, will be required. This must show that the tracking and lockable fitting are capable of meeting the strength requirements of the Directive independently of the vehicle when supporting a seat of the type being inspected.
4. All the holes for bolts in each seat leg or tracking used for mounting the seat or tracking to the structure of the vehicle must be fitted with appropriately sized bolts. If hole sizes are not available from the seat test certificate, or if other evidence is not available to show that fewer bolts will suffice, the examiner will assume that all holes in a particular seat pedestal are required for mounting the seat or tracking to the vehicle. Undersized bolts should be rejected unless documentary evidence is available to verify that the seat or tracking can meet the requirements when secured with these fasteners.
5. Tracking systems may be sub-divided into two broad categories. For the purpose of this assessment, “low profile” tracking will be regarded as tracking whose total height from its lowermost to its uppermost surface is less than 30mm. “Heavy duty” tracking is tracking whose total height from its lowermost to its uppermost surface is greater than 30mm.

Specific Requirements for M2 panel van conversions

There are two basic categories that these vehicles will fall into:

1. **Vehicles fitted with “overfloor” reinforcements (i.e. steel plates or frameworks inside the vehicle between the inner plywood floor, and the sheet steel floor).** These vehicles cannot be effectively assessed when the vehicle is complete. However, the Certifying Officer may be satisfied if there is evidence from the manufacturer of a test to the correct criteria in a similar vehicle on the type of flooring system installed between the vehicle floor and the plywood floor. The Certifying Officer may want to satisfy himself through a visual inspection (this will probably have to be done in build, and then the remaining panels etc fitted prior to the certification examination), that the flooring system and attachments are the same as the “pull tested” components. The Certifying Officer would have to bear in mind the time/financial elements of using this option. The onus would be on the manufacturer to present the vehicle to the Certifying Officer.

If the Certifying Officer is satisfied with the design, i.e. that the strength of the anchorages is borne by part of the structure and not an add-on plate, he may decide not to inspect remaining vehicles in a batch of identical vehicles. However, declarations from the manufacturer to this effect will be required.

2. Vehicles fitted with “under floor” reinforcements (i.e. load spreading plates, washers and steel sections under the vehicle. These may be assessed as follows:

Single seats with integral belt anchorages secured directly to the vehicle floor (i.e. not via tracking) must be fitted with load spreading plates under the vehicle floor at each rear leg, and between each front leg and the vehicle floor. These plates need to be a minimum of 75mmx75mmx4mm mild steel. Where the mounting bolt is within 40mm of a structural chassis member, the plate may be folded **but not cropped** to clear the member.

Where pairs or groups of single seats are fitted next to one another (or to existing double seats) to form double or triple seats, such seats must be fitted with reinforcing members under the vehicle floor. The reinforcement needs to consist of one longitudinal 75mm wide channel section per seat pedestal underneath the floor if the distance between the legs of the seats is greater than 75mm. If the distance between the pedestals is less than 75mm, a single longitudinal section of channel 100mm wide will be sufficient. The height and thickness of the channel will be the same as that for double seats (38 & 5mm respectively). Load spreading plates should still be fitted between the front seat legs and the inside of the vehicle floor. Where there is a gangway between adjacent seats, the seats can be treated as individual seats and no further reinforcement of the vehicle floor is necessary, other than that specified elsewhere in this document. In all cases, the ends of the channel sections must abut snugly against the bearers immediately in front of and behind the seat concerned.

Single seats fitted to “low profile” tracking will be considered to meet the requirements of this inspection if the tracking is secured at intervals of not more than 105mm using 8mm grade 8.8 (or better) fasteners. Load spreading washers or plates should be fitted under the vehicle floor. If plain washers are used, these should be a minimum of 50mm diameter and 3mm thick. In cases where the centre of a securing bolt is within 20mm of a chassis member, the washer may be cropped to clear the cross member. If plates are used, these should be a minimum of 35mm wide and 3mm thick and should present a rounded edge of at least 2mm radius towards the sheet steel floor. Plates and washers should, wherever possible, either span adjacent corrugations or approximately follow the contours of the corrugations.

Single seats fitted to “heavy duty” tracking will be considered to meet the requirements of this inspection if the tracking is secured at intervals of not more than 300mm using pairs of 8mm grade 8.8 (or better) fasteners, either side of the tracking centreline. Load spreading plates at least 50mm x 50mm x 3mm thick should be used under the vehicle floor at each mounting point.

Double seats with two pedestals and integral belt anchorages fitted directly to the vehicle floor and not on tracking, should be fitted with substantial channel or box section reinforcements under the vehicle floor. These must run longitudinally under each of the legs and extend as far forward and rearward as the next structural cross member. Channel sections should be at least 76mm x 38mm x 5mm positioned with the flanges facing downwards. If box sections are used, similar exterior dimensions should be used and the wall thickness must be at least 4mm. In addition, seat mounting bolts passing through the box sections must be fitted with “crush tubes” to prevent the walls of the box section deforming as the bolt is tightened. (Because these crush tubes are usually not visible in the completed vehicle the onus would be on the presenter to satisfy the Certifying Officer these were fitted). Both channel and box section reinforcements **must** abut snugly against adjacent cross members. The cut ends of such members should be radiused to reduce the tendency to tear through the vehicle floor in the event of an accident. In addition, reinforcing plates at least 100mm x 100mm x 4mm must be fitted between the front legs and the **inside** of the vehicle’s steel floor.

Double or triple seats fitted to tracking require documentary evidence to verify that the seat and its associated fittings are capable of satisfying the requirements, when fitted to the vehicle.

Triple seats with integral belt anchorages that are fitted directly to the vehicle floor, normally have three symmetrically spaced legs. These should be secured to the vehicle floor using the same methods and reinforcement sizes as those for a double seat with two legs.

Where seats are fitted over a wheel arch and the outboard leg of the seats is mounted through the arch, then a bridge structure secured to the underside of the arch is required. This structure should span the arch, and if flat plate should be at least 75mm wide and 4mm thick, if channel or box section is used it should be of equivalent strength to the flat plate.

Specific Requirements for M3 panel van conversions

M3 panel van conversions are rare, as few such vehicles have Gross Vehicle Weights exceeding 5 tonnes. It is, however, possible to occasionally encounter such vehicles. For the purposes of this inspection, therefore, these vehicles should be treated as “M2” panel van conversions i.e. the same sizes of reinforcing members and plates should be fitted. Although the required test loads for M3 vehicles are lower than those required of an M2 vehicle, there is currently insufficient test data available on such vehicles to allow meaningful guidelines to be established. In addition, the differences in size between these vehicles and their M2 counterparts are such that it might be possible to encounter larger expanses of unsupported floor area in these vehicles than in similar “M2” vehicles.

Specific Requirements for M2 “coach built” vehicles.

This covers vehicles where floors are constructed by securing cross bearers to the main longitudinal rails of the chassis at various intervals. Seats can then be secured either directly to the cross bearers or to additional longitudinal members or tracking, running between the cross bearers.(see photograph on page 11).

Typically, the cross bearers themselves will be made of box, channel or “top hat” section running across the main chassis members. The cross bearers must be:

- i) at least as deep as any longitudinal members used to secure the seats, and
- ii) either be at least one gauge thicker than the material used for those longitudinal members or, where the cross bearer section is the same thickness but deeper, have an 'I' value (second moment of area) equal to or greater than the 'I' value of the thicker material option. The calculation of the relative 'I' values must be demonstrated/proved to the Certifying Officer's satisfaction and be supported by full documentary evidence. [Specification tables/calculation etc.]

Where seats are attached to longitudinal members, the size of those members will vary depending on how far apart the cross bearers are, Tables 1-3 below set out the required mild steel channel section sizes, for various distances between cross bearers. If box sections are used, similar exterior dimensions and wall thickness must be chosen. Seat mounting bolts passing through the box sections must be fitted with “crush tubes” to prevent the walls of the box section deforming as the bolt is tightened. (Because crush tubes are normally not visible in the completed vehicle the onus would be on the presenter to satisfy the Certifying Officer that these were fitted).

Where tracking is used to mount the seats, it may be secured directly to cross bearers, although in some cases there will be a longitudinal member between the tracking and the cross bearer. In general, where tracking is secured to a cross bearer in more than one place, (e.g. where two lengths of tracking meet on the same cross bearer or where one length of tracking is fastened at two points on the same cross bearer) the distance between successive bearers is to be taken as the shortest distance between tracking fastener centers through the cross bearer.

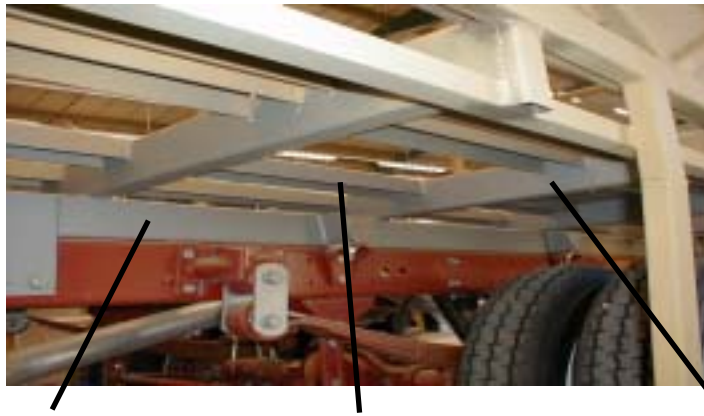

This is classed as
Chassis, Not defined

Longitudinal member
See tables 1 to 3 on pages

Cross Bearer

Table 1. Minimum channel section sizes for seats fitted directly to the vehicle.

Seat Type	Distance between successive bearers		
	<400mm	400mm-600mm	600mm-800mm
Single	50 x 25 x 3mm channel	50 x 30 x 4mm channel	50 x 40 x 4mm channel
Double with 2 legs	50 x 30 x 4mm channel	50 x 40 x 4mm channel	100 x 50mm standard channel
Double with 3 legs	50 x 30 x 3mm channel	50 x 40 x 4mm channel	76 x 38mm standard channel
Double with 4 legs	50 x 25 x 3mm channel	50 x 30 x 4mm channel	50 x 40 x 4mm channel
Triple with 3 legs	50 x 30 x 4mm channel	50 x 40 x 4mm channel	100 x 50mm standard channel
Triple with 4 legs	50 x 30 x 3mm channel	50 x 40 x 4mm channel	76 x 38mm standard channel
Triple with 6 legs	50 x 25 x 3mm channel	50 x 30 x 4mm channel	50 x 40 x 4mm channel

Table 2. Minimum channel section sizes for seats fixed to “Low Profile” tracking.

Seat Type	Distance between successive bearers		
	<400mm	400mm-600mm	600mm-800mm
Single	50 x 25 x 3mm channel	50 x 30 x 3mm channel	50 x 40 x 4mm channel
Double with 2 legs	50 x 30 x 4mm channel	50 x 40 x 4mm channel	76 x 38mm standard channel

Table 3. Minimum channel section sizes for seats fixed to “Heavy Duty” tracking.

Seat Type	Distance between successive bearers		
	<400mm	400mm-600mm	600mm-800mm
Single	not specified	not specified	125 x 25 x 2mm channel
Double with 2 legs	not specified	125 x 25 x 2mm channel	125 x 40 x 3mm channel

Specific Requirements for M3 “coach built” vehicles.

This covers vehicles where floors are constructed by securing cross bearers to the main longitudinal rails of the chassis at various intervals. Seats can then be secured either directly to the cross bearers or to additional longitudinal members or tracking running between the cross bearers. (see photograph on top of page.

Typically, the cross bearers themselves will be made of box, channel or “top hat” section running across the

main chassis members.

The cross bearers must be:

- i) at least as deep as any longitudinal members used to secure the seats, and
- ii) either be at least one gauge thicker than the material used for those longitudinal members or, where the cross bearer section is the same thickness but deeper, have an 'I' value (second moment of area) equal to or greater than the 'I' value of the thicker material option. The calculation of the relative 'I' values must be demonstrated/proved to the Certifying Officer's satisfaction and be supported by full documentary evidence. [Specification tables/calculation etc.]

Where seats are attached to longitudinal members, the size of those members will vary depending on how far apart the cross bearers are, Tables 1-3 below set out the required mild steel channel section sizes for various distances between cross bearers. If box sections are used, similar exterior dimensions and wall thickness must be chosen. Seat mounting bolts passing through the box sections must be fitted with “crush tubes” to prevent the walls of the box section deforming as the bolt is tightened. (Because crush tubes are usually not visible in the completed vehicle the onus would be on the presenter to satisfy the Certifying Officer these were fitted).

Where tracking is used to mount the seats, it may be secured directly to cross bearers, although in some cases there will be a longitudinal member between the tracking and the cross bearer. In general, where tracking is secured to a cross bearer in more than one place, (e.g. where two lengths of tracking meet on the same cross bearer or where one length of tracking is fastened at two points on the same bearer) the distance between successive cross bearers is to be taken as the shortest distance between tracking fastener centers through the cross bearer.

Table 1. Minimum channel section sizes for seats fitted directly to the vehicle.

Seat Type	Distance between successive bearers		
	<400mm	400mm-600mm	600mm-800mm
Single	50 x 25 x 2mm channel	50 x 25 x 3mm channel	50 x 30 x 4mm channel
Double with 2 legs	50 x 30 x 3mm channel	50 x 40 x 4mm channel	76 x 38mm standard channel
Double with 3 legs	50 x 25 x 3mm channel	50 x 30 x 4mm channel	50 x 40mm x 4mm channel
Double with 4 legs	50 x 25 x 2mm channel	50 x 25 x 3mm channel	50 x 30 x 4mm channel
Triple with 3 legs	50 x 30 x 3mm channel	50 x 40 x 4mm channel	76 x 38mm standard channel
Triple with 4 legs	50 x 25 x 3mm channel	50 x 30 x 4mm channel	76 x 38mm standard channel
Triple with 6 legs	50 x 25 x 2mm channel	50 x 25 x 3mm channel	50 x 30 x 4mm channel

Table 2. Minimum channel section sizes for seats fixed to “Low Profile” tracking.

Seat Type	Distance between successive bearers		
	<400mm	400mm-600mm	600mm-800mm
Single	50 x 25 x 2mm channel	50 x 25 x 3mm channel	50 x 30 x 4mm channel
Double with 2 legs	50 x 30 x 3mm channel	50 x 40 x 4mm channel	50 x 40mm x 4mm channel

Table 3. Minimum channel section sizes for seats fixed to “Heavy Duty” tracking.

Seat Type	Distance between successive bearers		
	<400mm	400mm-600mm	600mm-800mm
Single	not specified	not specified	125 x 25 x 2mm channel
Double with 2 legs	not specified	125 x 25 x 2mm channel	125 x 30 x 3mm channel

Seats fitted to the vehicle sidewall.

It is common practice to fit the outboard end of a double coach seat to an aluminium extrusion, on the sidewall of the vehicle. Documentary evidence should be sought that the extrusion, the seat assembly and its mounting brackets are capable of meeting the requirements of the Directive when tested independently of the vehicle. The extrusion itself should be secured to structural members within the vehicle sidewall at intervals of not more than 500mm.

Rear “Bench” type Seats in “M2” and “M3” Vehicles.

It is common practice to fit a single “bench” type seat across the back of most coaches, buses and some minibuses. Such a seat might typically be designed to accommodate up to 5 adults across the width of the vehicle. These seats tend to be mounted in a different way to those in the main saloon area of the vehicle – typically, they are not mounted on separate “pedestals” but on to a “box”-like structure above the vehicle’s engine bay or luggage area. Clearly these seat mountings cannot be inspected in the same way as the other seats in the vehicle.

If all seating positions on such a seat were to be fitted with three-point belts, the required test load would be in the order of 80kN (about 8 tonnes) for an “M2” vehicle and about 50kN (5 tonnes) for an “M3” vehicle. These large forces arise because the load must be applied simultaneously to all the seats in the row. To withstand such loads a substantial structure must be provided to which to attach the seats.

In assessing the vehicle structure in this area, the following points should be considered:

- 1) Establish whether the seats are 5 single seats (less pedestals) or a combination of single, double or triple seats.
- 2) Ensure that certification is available for the seats used. The seats will generally have been tested on pedestals and will not be fitted to these but the certificate for the seat will give some confidence that the seat frame, and particularly the upper anchorage (if fitted) is capable of meeting the requirements.
- 3) Ensure that the seat has been secured to the vehicle using **at least** as many fasteners as would be required to secure it to its pedestal(s) and that these fasteners appear to be of a type suitable for this purpose. If bolting directly through box section, spreader washers at least the same diameter and thickness as the section should be fitted between the underside of the box section and the fastener heads.
- 4) Assess the structural members under the area of floor to which the seats are attached. There will be many different ways of constructing a framework or structure to carry the loads under the seats. The simplest would be to provide two cross members – one under the rearmost part of the seats and one under the foremost parts. Often, these cross members will be linked with longitudinal members to which the seats themselves are secured.
- 5) Assess the size and method of attachment of any longitudinal members to which the seats are attached. Typically, these will be smaller channel, box or angle sections than the main members and they should be at least of similar size and strength as the top section of the pedestals to which similar seats elsewhere in the vehicle would be attached.

In most cases, the main crossmembers under the rear row of seats will be completely unsupported -other than at their ends, to allow access to the luggage or engine compartment. If this is the case, these members will have to be very substantial to withstand the loads applied. In assessing their suitability, the following table must be applied. **NOTE:** Some vehicles may have been successfully tested with considerably smaller sections -particularly if additional members or sheet steel panelling has been used to feed the loads into a greater surrounding area than the immediate underfloor structure provides. ***If satisfactory proof of a test is available from the presenter, this should be accepted even if the vehicle structure does not conform to the requirements in the table.***

Vehicle category & belt type	Minimum Required Crossbearer size for Rear “Bench” type Seats.
M2 with lap belts	100 x 50 x 3.2mm Mild steel box section

M2 with 3-point belts	100 x 50 x 4mm Mild steel box section
M3 with lap belts	90 x 50 x 3mm Mild steel box section
M3 with 3-point belts	90 x 50 x 3.6mm Mild steel box section

In general, the *depth* of a section is more important than its width and should therefore not be compromised. For example, a 100 x 40 x 6mm section would be an acceptable alternative to a 100 x 50 x 5mm section provided that the orientation of the section was such that the 100mm dimension was vertical.

A number of other factors should be taken into account when assessing suitability.

- The method by which the cross members are attached to the vehicle sidewalls should be appropriate to the size of the cross members. A 100x100x5mm section will require considerably more substantial end attachments than a 90 x 50 x 4mm cross member.
- Many coaches have substantial end frames to provide rollover protection. This section of such a vehicle is likely to be inherently very strong. If there are additional frame members (or sheet steel panelling) attaching the main cross members to the vehicle, these may substantially increase the strength of the structure as a whole and this should be taken into account when assessing the suitability of the main cross members.

Appendix 2

Reference Zone

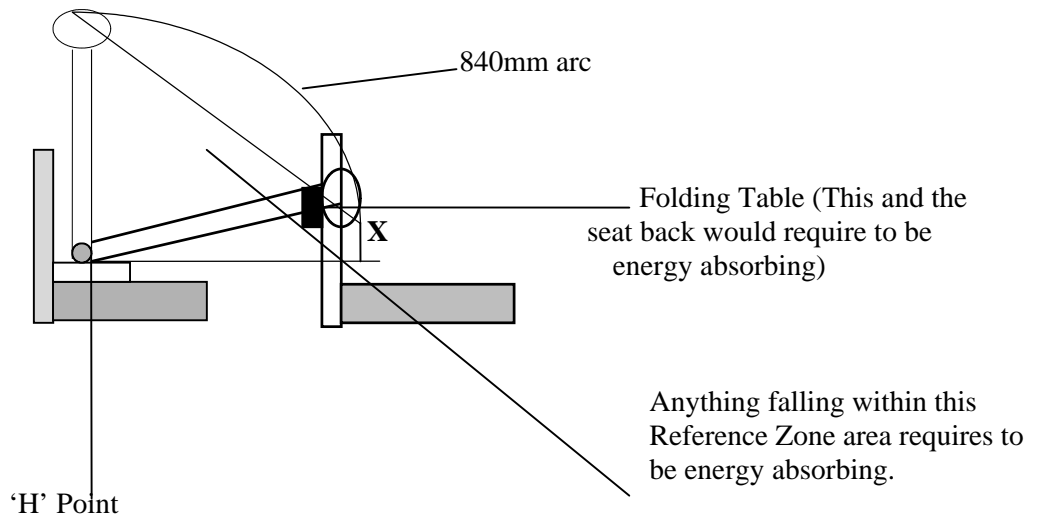
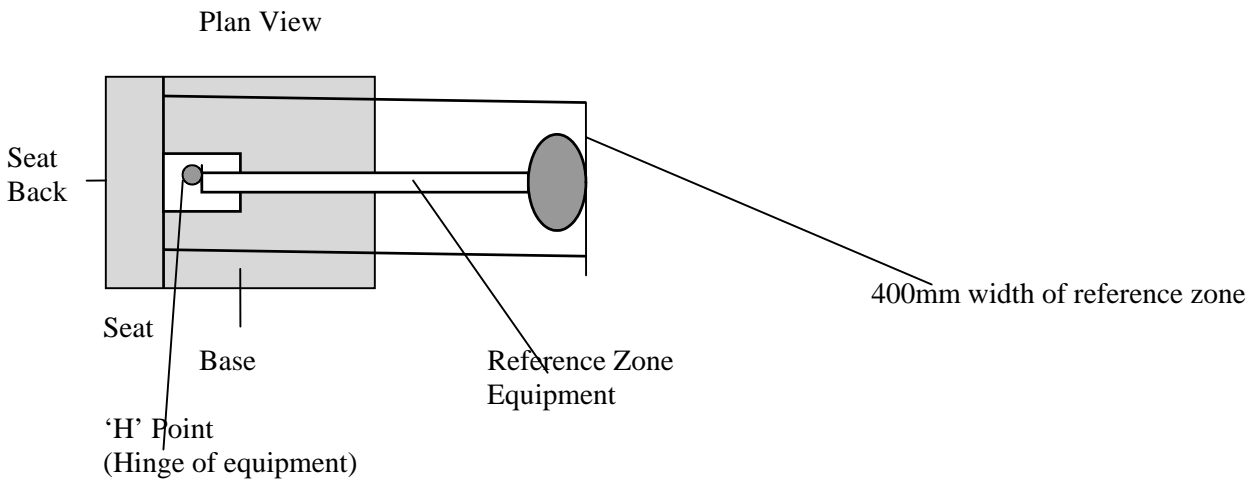

Note :- X = Lower position of the reference

Appendix 3

