



O1 Category Trailer - up to 750kg

O2 Category Trailer - 750kg to 3500kg

(mass on the axles)

Trailer Type Approval Seminar

Agenda

- **Type Approval Process**
- **Type Approval Subjects**
- **Conformity of Production**
- **Support & Information services**
- **Application & Initial Contacts**

ECWVTA Revised Framework Directive

EC Whole Vehicle Type Approval is being extended to cover all new road vehicles and trailers

Timetable for the enforcement

	New Types	Existing Types
Incomplete / Complete	29 October 2010	29 October 2012
Completed	29 October 2011	29 October 2013
Special Purpose	29 October 2012	29 October 2014

NO APPROVAL NO SALE

ECWVTA Revised Framework Directive

New or Existing Types..???

Existing Type – The specific type of trailer is currently
Manufactured in the UK /
Exported to a EU country

New Types – A new design or trailer type
Manufactured in the UK /
Exported to a EU country

Exporting a trailer type to an EU country for the first time means ECWVTA is mandatory as of 29th October 2010

Which Type Approval route?

As a Manufacturer, there are three options of approval available:

- **IVA** (Individual Vehicle Approval)
 - UK / Issuing member state only. Inspection of each vehicle, no limit on numbers, **NO CoP**
- **NSSTA** (National Small Series Type Approval) - **UK only** / Issuing member state only. A limit of 500 trailers belonging to one Type per year. There are however 'eased' technical requirements
- **ECWVTA** (EC Whole Vehicle Type Approval)
 - Full technical & administrative requirements



ECWVTA & NSSTA in a Nutshell

Type Approval authorises a manufacturer to:

- Produce vehicles, systems and components to a proven specification and;
- Self-certify these as compliant with relevant legislation

Two fundamental requirements:

- Meeting the technical and administrative requirements and capturing the design
- Ensuring that subsequent production is manufactured in conformance with the approved design

Type Approval Hierarchy

For NSSTA and ECWVTA there are three key steps to follow:

1. **Whole Vehicle Type Approval**
2. **Trailer System Approvals Or Test Reports**
Brakes, Glass, Tyres, Lighting etc.
3. **Conformity of Production, Research & Development, etc.**

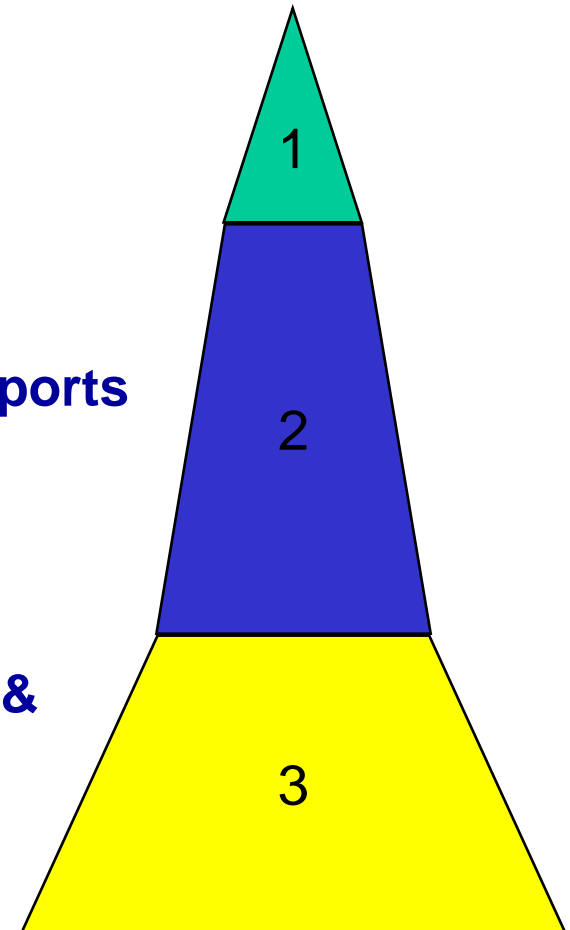

Your Product Range and ECWVTA

For NSSTA and ECWVTA your trailer range will be divided up using the following criteria. It is worth remembering that each Type needs its own Certificate of Approval.

Type –

- Manufacturer
- Category
- Chassis (fundamental differences)
- Number of Axles
- Braking System (Braked, Un-braked)

Variant –

- Body Style
- GVW difference >20%
- Steered Axles

Version – **Combination of Options**

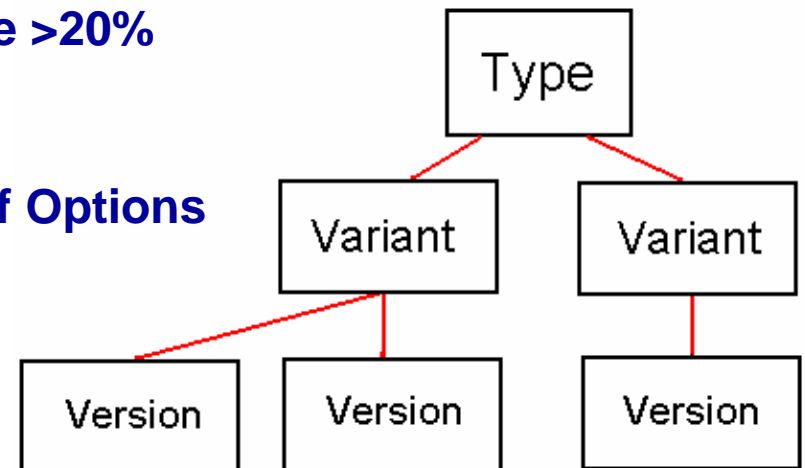

Technical Requirements

For ECWVTA and NSSTA the technical requirements cover the following:

- Rear Protection Device
- Registration Plate Space
- Steering Effort
- Braking
- Radio Interference
- Statutory Plates
- Installation of Lighting
- Heating Systems
- Spray Suppression
- Safety Glazing
- Tyres
- Masses and Dimensions
- Couplings
- Transport of Dangerous Goods



Regulation or Directive

	<u>UNECE Regulation</u>	<u>EEC Directive</u>
Rear Protection Device		70/221
Registration Plate Space		70/222(1003/2010)
Steering Effort	79.01	70/311
Braking	13.11	71/320
Radio Interference	10.03	72/245
Statutory Plates		76/114(19/2011)
Installation of Lighting	48.04	76/756
Heating Systems	122.00	2001/56
Spray Suppression		91/226(2010/19)
Safety Glazing	43.00	92/22
Tyres		92/23
Masses and Dimensions		97/27
Couplings	55.01	94/20
Transport of Dangerous Goods	105.04	98/91

Type Approval Application Document

2007/46 Whole Vehicle Information Document

Annex 1 – Complete List

Test Reports for each subject

1 Whole Vehicle Certificate

1 Detailed Information
document

Annex 3 – Accompany List

Test Reports or Certificates for
each subject

1 Whole Vehicle Certificate

>1 Systems Certificates

Multiple Information
Documents

Whole Vehicle Approval Hierarchy

Three fundamental whole-vehicle Type Approval categories are available under both ECWVTA and NSSTA

1. Complete vehicle approval

- covers **single-stage manufacture** of a fully finished product

2. Incomplete vehicle approvals

- controls the specification of a partially assembled vehicle
- multiple approvals sometimes required
- can reduce Type Approval requirements for the final stage manufacturer

3. Completed vehicle approval

- **final assembly of a multi-stage vehicle** as a fully finished product

Technical Requirements

The following information is to be used only as a guide.

It should not be used as a substitute to the legislation.

Note: *The following tests are non destructive and VCA always endeavour to look after products. However during the loading of ballast and brake testing, small marks may be unavoidable. We also test the break away cable which is destructive.*

Fuel Tanks & Rear Protection Devices

“Tank” means the tank(s) designed to contain liquid fuel, used primarily for the propulsion of the vehicle.

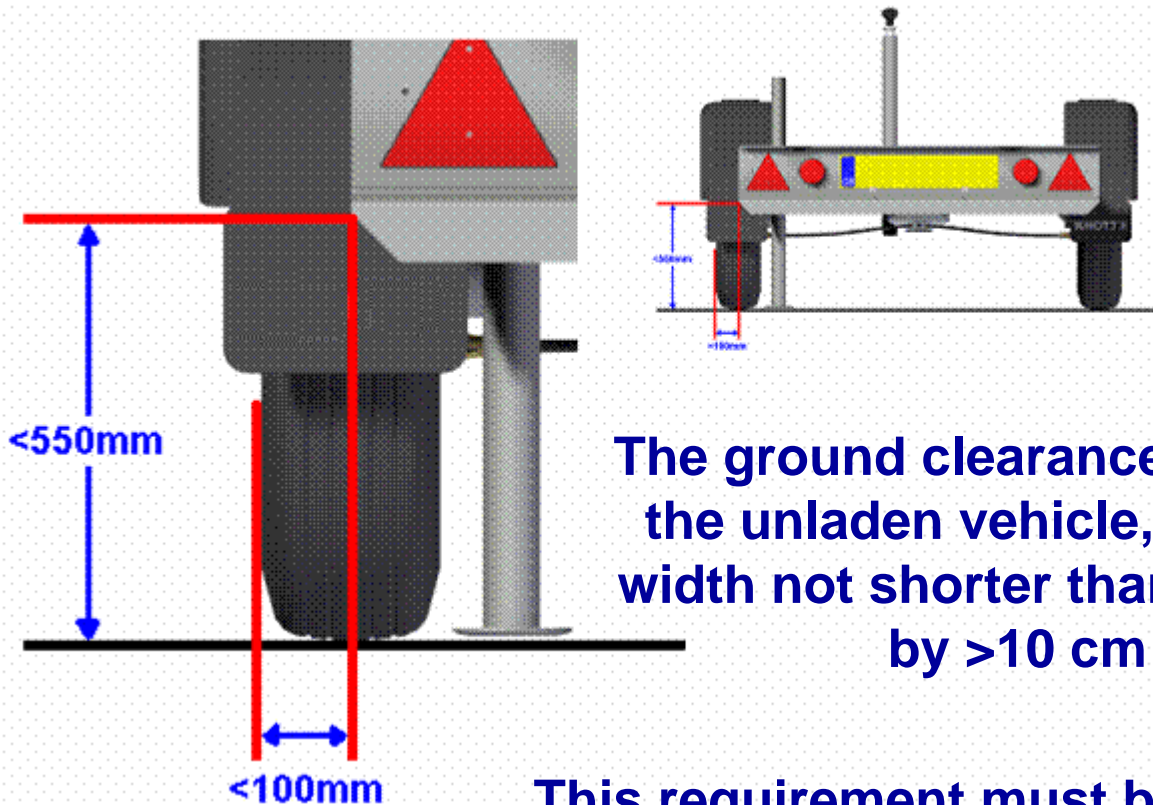

The ground clearance of the rear of the unladen vehicle, $<55\text{cm}$ over a width not shorter than the rear axle by $>10\text{ cm}$ on either side

This requirement must be satisfied $<45\text{ cm}$ from the rear of the vehicle.

Rear Registration Plate Space

The space for mounting shall comprise of a flat or virtually flat rectangular surface with the following minimum dimensions:

520mm x 120mm

or

340mm x 240mm

- Position of the plate horizontally
(Centre or Left)
- Position of the plate vertically
- Angle of the plate
- Geometrical visibility

Common Problem

- Lights too close so they intrude on the outward visibility angle.
- Part of the trailer intrudes on the visibility angle

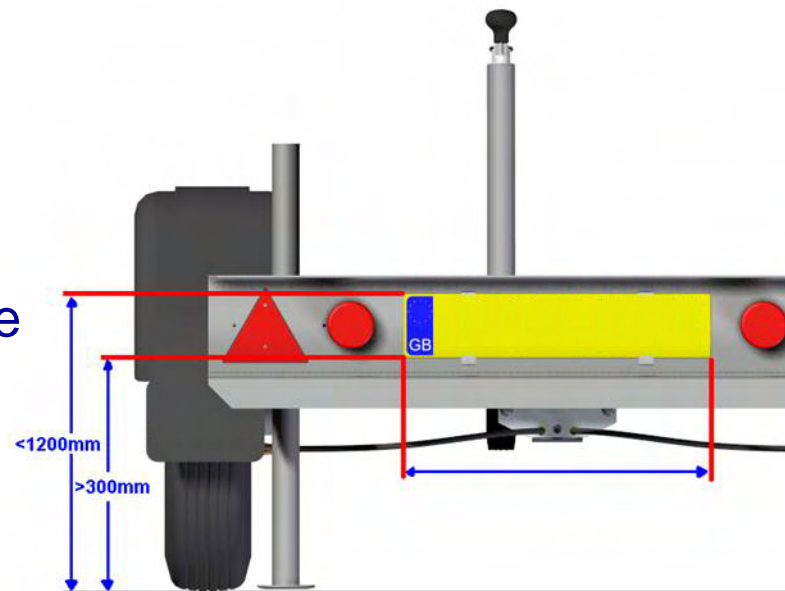

Steering Effort

This Directive applies to the steering equipment of all vehicles in categories O.

“Steering equipment” means all the equipment the purpose of which is to determine the direction of movement of the vehicle

Steered Axles have an effect on Braking, in Regulation-13 braking operated by an Overrun Device is not permitted.

As of 2014 Directive 71/320/EEC repealed, leaving Regulation 13 only.

Braking

Common Problems

- Poor brake performance on the Hill Hold test
 - Trailers delivered without the brakes adjusted
 - Trailers delivered without the brakes bedded
- No locknuts fitted on the brake rods
- Handbrake lever travel restricted
- Brake Compatibility not provided or checked

Radio Interference

Most trailers are only fitted with a simple lighting circuit.

However Caravans etc will have electrical components such as:

- Fridges
- Combi-Boilers
- Televisions

These components are generally all approved as a separate unit or turned off via a relay when the trailer is connected to a towing vehicle.

Some Complex LED lights also require EMC approval

Statutory Plates

1 – Manufacturer's Statutory Plate

Layout

Character Size (*Min height 4mm*)

17 Digit VIN Construction

GVW / Coupling Mass/ Axle Mass

Location

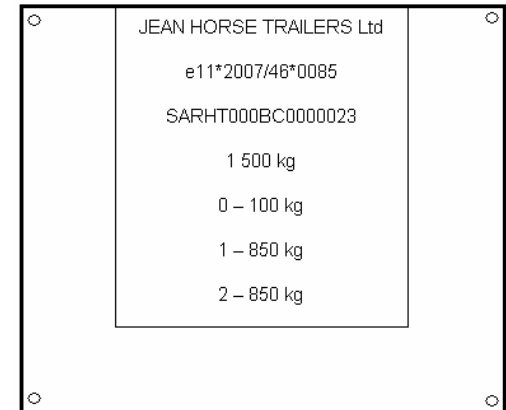

2 – VIN Number Chassis Stamping

Character Size (*Min height 7mm*)

Unique to a particular Vehicle

Location (*Right hand side of vehicle*)

Statutory Plates

WMI Number
World Manufacturer
Identifier

VIN Construction

The VIN shall consist of three sections:

1. the world manufacturer identifier (**WMI**)
2. the vehicle descriptor section (**VDS**)
3. the vehicle indicator section (**VIS**)

WMI – Assigned to the vehicle manufacturer

VDS – 6 characters, to indicate the characteristics of the vehicle

VIS – 8 characters, the last four shall consist of digits only.

The VIN shall provide clear identification of a particular vehicle.

Installation of Lighting

A change is occurring for O2 trailers as the fitment of reverse lights means moving away from 7-pin connectors to 13-pin.

Simple List of Required Lamps / Reflectors

	O1	O2
Reversing Lamp	Optional	1 (2 if >6m length)
Rear Indicator Lamp		2
Stop Lamps		2
High Level Stop Lamp		Optional
Registration Plate Lamp		Such as to illuminate plate
Front Position Lamp		Optional <1.6m wide, Mandatory >1.6m
Rear Position Lamp		2
Rear Fog Lamp		1
Rear Triangular Reflector		2
Side Reflector		<3m from Front, <1m from Rear, <3m Between
Front Reflector		2
Side Marker Lamp		Mandatory >6m length
End Outline Marker Lamp		Optional 1.8 to 2.1m wide, Mandatory >2.1m

Installation of Lighting

Specific Problems

- No front position lamps or reflectors
- Front position lamps too far inboard
- No side marker lamps or reflectors
- No reverse lamps (7-pin connector)
- Protective bars over the lamps
- Lamps and reflectors installed at an angle
- Number plate lamps fitted too far apart to illuminate number plate
- Number plate lamps not fitted in accordance with approval

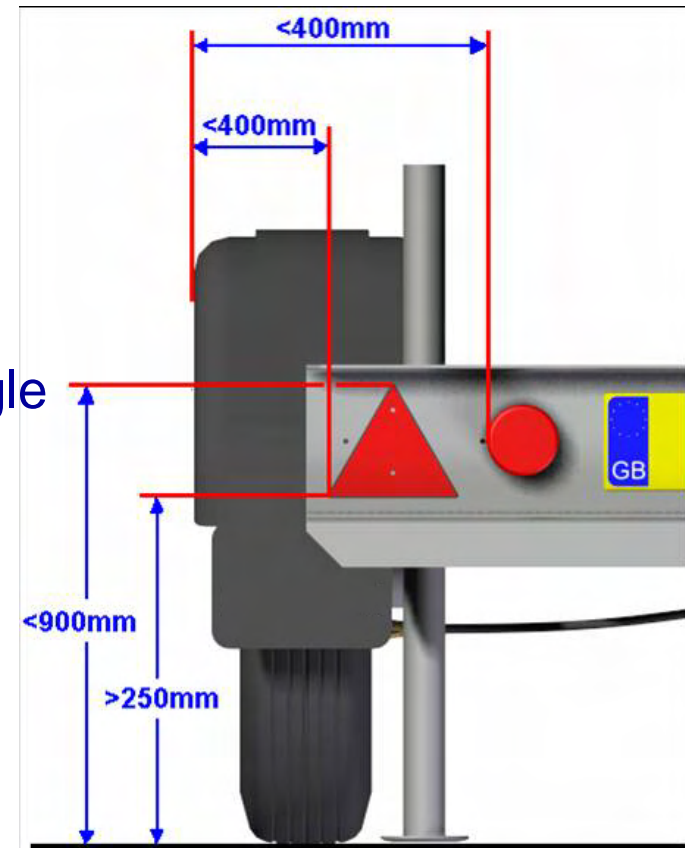

Installation of Lighting

Example of a specific problem and how to avoid it:

1)

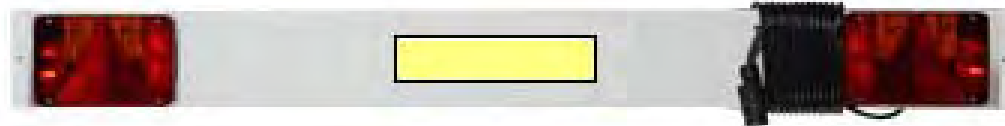

2)



3)

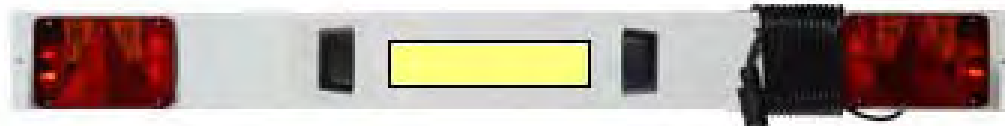

Refer to lamp approval for fitting information

Heating Systems

This Directive applies to all trailers in category O where a heating system is fitted.

“Heating system” means any type of device which is designed to increase the temperature of the interior of a vehicle, including any load area.

Spray Suppression Systems

2010/19/EU enforced on 9 April 2011 – Meaning Spray Suppression is mandatory for O1 and O2 category trailers.

However they are exempt from having to fit a spray suppression device

Requirements

Mudguard

Valances

Rain Flaps

~~Air/Water Separator (matting)~~



Safety Glazing

All glazing bears the EEC component type approval mark and any additional symbol

For special purpose trailers the glazing just needs to be approved

This can be useful where manufacturers require low volumes of a specific design

Case by case

Tyre Installation



Installation

Make / Model

Size Fitted

Load Capacity

Speed Rating

E-Mark

Sound E-Mark (>10" diam.)

You will NOT be restricted to a particular Make and Model of Tyre only the Key Information underlined (Annex 3)

Masses and Dimensions

Trailer Dimensions

- Length
- Width
- Height

Trailer Mass

- Mass in running order on each axle and the coupling
- Maximum laden mass on each axle and the coupling
- Technically permissible maximum mass on each axle and the coupling

Masses and Dimensions

Can be straight forward or cause issues

Dimensional there have been no issues

Axle and nose weights can pose a problem

Key Issues

- Nose load too high
- Axle weight distribution laden
- Chassis angle when measuring

Couplings

- 1. Coupling Heads & Eyes – Pre Approved Part**
(Check D & S values + Installation)
- 2. Overrun Device – Pre Approved Part**
(Check D & S values + Installation)
- 3. Drawbar – Pre Approved, Requires Approval or Exempt**



Drawbars

Drawbars need to be approved if they are a separate technical unit.

The widely held view that bolt-on drawbars are separate technical units and drawbars welded to the main frame are not **is incorrect**

The method of attachment is disregarded when determining if the drawbar is a separate technical unit

What is classed as a Drawbar and requires approval?

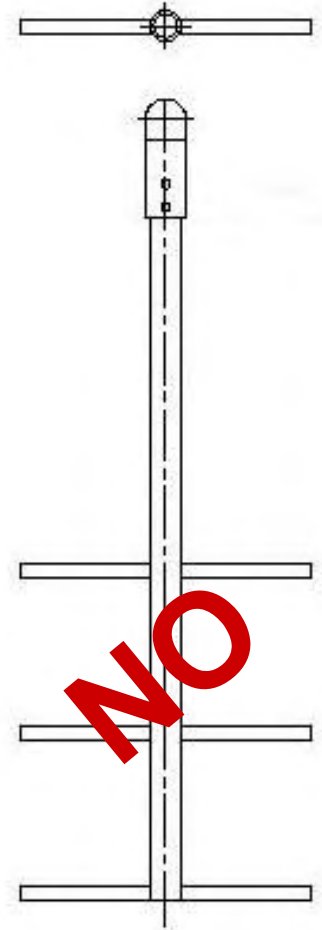
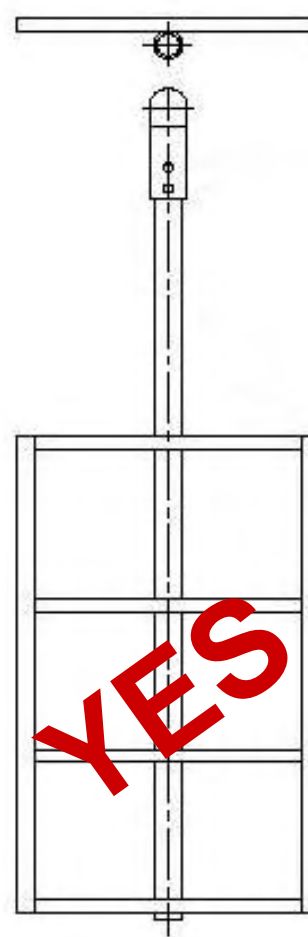
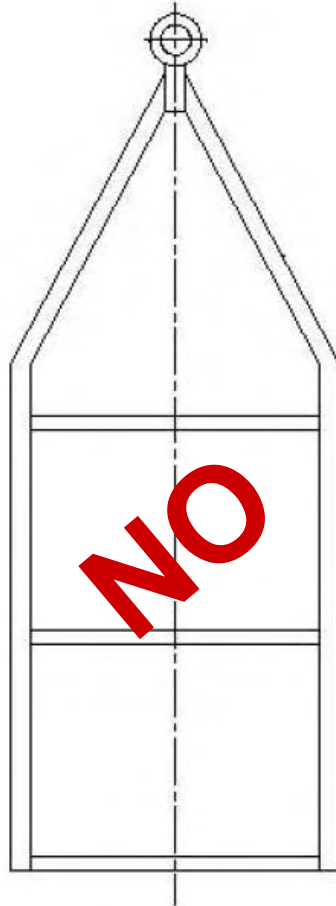
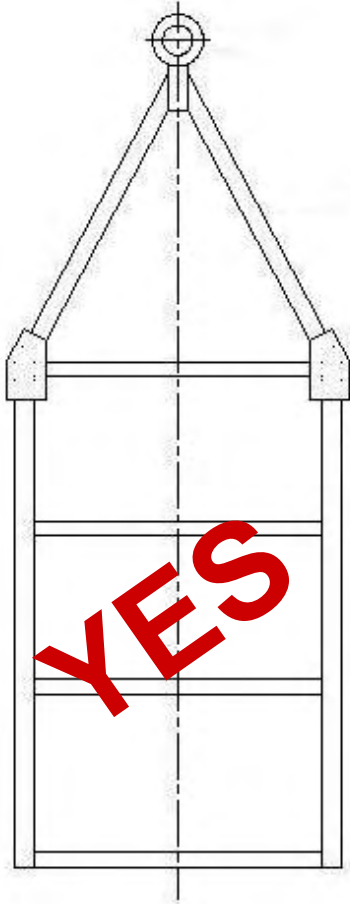

Couplings

If a trailer is deemed to have a drawbar comprising a separate technical unit, there are 3 options available:

- 1. Buy and fit an Approved Drawbar**
- 2. Calculation using ISO7641-1**
(simple design only)
- 3. Physical test of 2,000,000 cycles**
(94/20 EC or Reg55)

Regardless of Drawbar classification, we would like to see all trailers be put through one of the options above

Couplings

Once the Drawbar, Coupling Head and Overrun Device have been checked:

The final check

Height requirement for a **50mm ball** when trailer is **laden** to its maximum weight

430mm ± 35mm

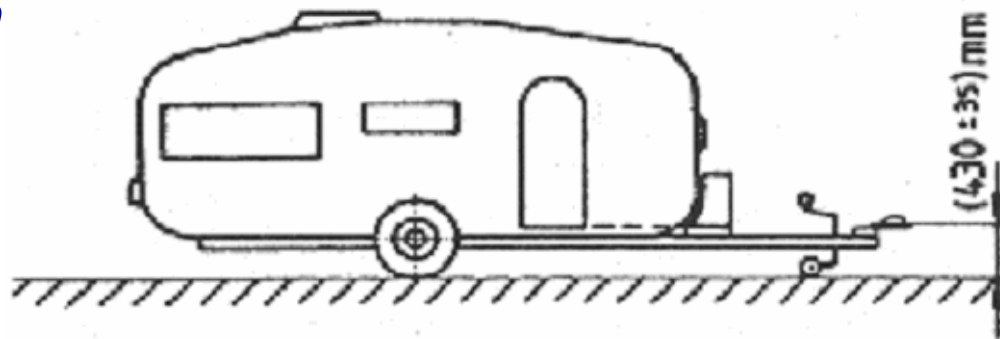

Transportation of Dangerous Goods

This Directive shall apply to any vehicle, whether complete (e.g. one stage built trailers), incomplete (e.g. trailer chassis), or completed trailers intended for the transport of dangerous goods by road.

A Plan of Action

1. Work out what to do

Understand the legislation

Plan what needs to be done

2. Get things right & ready

Develop compliant designs

Prepare approval documents

3. Make it so!

Get tests & reports done

Get final approval

Questions..???



O1 Category Trailer - up to 750kg

O2 Category Trailer - 750kg to 3500kg

(mass on the axles)

Conformity of Production



Change?

Change before you have to.

Jack Welch

Change brings opportunity.

Nido Qubein

If there is no struggle, there is no progress.

Frederick Douglass

Change is such hard work.

Billy Crystal



Agenda

- **Glossary**
- **What is CoP?**
 - **What does it affect?**
- **Should I be worried?**
- **What do I need to do?**
 - **The quality elements**
 - **Control Plans**
- **The audit**
- **Support and Information Services**

What is CoP?

- The ability to produce a series of products which conform to the specification and performance requirements of a relevant directive.
- Simplified; is the 10th, 100th 1000th the same as the one type approved?

CoP – What does it affect?



CoP – What does it affect?

CoP is only concerned with those aspects of a vehicle that are type approved

- Examples, change to the loading conditions
 - May affect; Brakes, Tyres, Masses and Dimensions
 - Change to the colour of a vehicle may affect, err nothing
 - If you add another subject, you need to consider the CoP implications

What does CoP affect

- Rear Protection Device
- Registration Plate Space
- ~~Steering Effort~~
- Braking
- ~~Radio Interference~~
- Statutory Plates
- Installation of Lighting
- ~~Heating Systems~~
- Spray Suppression
- ~~Safety Glazing~~
- Tyres
- Masses and Dimensions
- Couplings
- ~~Transport of Dangerous Goods~~

But what if I make.....



CoP – What does it affect?

- Multi stage builds
 - Second stage not responsible for base vehicle, only the components or systems added by the second stage
 - Close tie's required
 - Base builder may change something that could affect 2nd stage approval, without this tie up 2nd stage approval may become invalid.
 - Example, change of load rating on tyres



Should I be worried?

Good news:



Bad news:

Documenting it.....

What do I need to do?

- A Quality System

What do I need to do?

The quality system:

- Formal quality system
ISO9001/TS16949 + Control
plans

*However, formal quality system
not mandatory, therefore:*

- Quality documentation (manual) +
Detailed control plans + On-site
assessment

Quality Documentation

- Informal Quality System
- Quality Manual or documents used to ensure product consistency should contain, but not be limited to at least the following:
 - Approved suppliers
 - How does the company select and monitor suppliers?
 - Incoming goods
 - How does the company ensure supplied goods conform?

Quality Documentation

- Non-conforming goods
 - How does the company ensure that goods purchased or manufactured that do not conform are not used for production?
- Staff training
 - How does the company ensure staff are properly trained? How is this recorded?
- Calibration
 - How does the company ensure that all relevant equipment is calibrated?

Quality Documentation

- Change Control
 - Important one this one. How does the company ensure that any changes to the design or performance of the product which might affect the validity of the approval is notified to the authority?
- Final inspection
 - How does the company ensure that the final product conforms?

This is a minimum list, quality documentation should be sufficient for the product and have continual improvement in mind

What do I need to do?

- **Control Plans**



Control Plans

- What is a control plan?
 - A control plan is a documented description of the procedures, checks and activities necessary to verify that the production unit continues to conform to the type approval requirements with regard to specification, marking and performance



Control Plans (continued)

- Control plan layout
 - There is no mandatory layout, you choose what suits your needs best
 - Electronic or paper copies acceptable
 - The control plan should become part of your quality system, the results generated will be inspected during any surveillance audit

Control Plans. Trailers

Subject	Legislation		CoP Requirements		
	DIR	REG	Insp Type	Freq	Control Doc
Lighting Installation	76/756	48	1	1/ Year	IVXX4
			2	1/mth	IVXX7
			4	100%	
Key					
Inspection Type 1			Vehicle Test (Reg/Dir)		
Inspection Type 2			Visual/Dimensional Verification		
Inspection Type 3			Record details in log		
Inspection Type 4			Functional Check		
Inspection Type 5			Supplier CoP		

Control Documents

Control Description Sheet – IVXX4

Lighting Installation

Procedure	Description	Inspection Type	Responsibility	Record
BBB1	Rear light position	2	Quality dept	CoP record
	Number plate position	2	Quality dept	CoP record
	Side outline markers	2	Quality dept	Cop Record
	Functional Check	2	Inspection	Build log

Procedure

Procedure BBB1- Lighting Installation

Rear light Position	Measure rear light position in accordance with R48. Check visibility angles
Number plate position	Measure number plate position in accordance with R48. Check visibility angles
Side outline markers	Measure number plate position in accordance with R48. Check visibility angles
Visual check	Check lighting for functionality and damage
???????	?????????????

Control Plans. Trailer

Subject	Legislation		CoP Requirements		
	DIR	REG	Insp Type	Freq	Control Doc
Rear Underrun	70/221	58	1	1/ Year	<i>IVXX3</i>
			5	-	N/A
			4	100%	
Key					
Inspection Type 1			Vehicle Test (Reg/Dir)		
Inspection Type 2			Visual/Dimensional Verification		
Inspection Type 3			Record details in log		
Inspection Type 4			Functional Check		
Inspection Type 5			Supplier CoP		

What's a good control plan

- Clear and unambiguous
- Suitable for the subject
- In a format that suits the manufacture and is acceptable to the VCA
- Demonstrates compliance
- Flexible

What's a poor control plan

- Disjointed
- B.O.M (Bill of material is not a control plan)
- Rigid
- Insufficient information
 - Test/measurement description
 - Method of recording
 - Frequency
 - Responsibility



Typical Audit Schedule

- Opening Meeting – Outline of Audit
- Quality/procedure manual review
- Overview of CoP system/ Control plans
- Site visit. Production line work instructions /equipment / end of line testing
- Document control. EC legislation / drawings / obsolete documents

Typical Audit Schedule

- Records. Test reports / calibration / suppliers
- Change control. Design / development / documentation
- Purchase. Supplier selection / supplier monitoring
- Calibration. In-house/external/ process/traceability

Typical Audit Schedule

- Control of N/C goods.
Supplier/production. Quarantine area
- Product storage. Stock rotation/storage
- Review / Questions
- Audit summary
- Close



Audit result:

- CoP Clearance granted
- CoP Clearance pending – non-conformances to be addressed
- Clearance granted for 1-3 years depending on risk rating and evidence of conformity.

And Finally (nearly)

- Look at VCA as your partner.
 - VCA has over 25 years experience in dealing with type approval and CoP around the world
 - Experience in every sector (car, bus, truck, trailer, motorcycle, agricultural)
 - We can help you interpret legislation (we are linked to policy makers in London and Europe)
 - Advise on quality documentation
 - Advise on control plans
 - Help you through the process in the most efficient and cost effective way
 - Your success is our success

Tools available:

- www.dft.gov.uk/vca
 - Conformity of Production guidance
 - Legislation information notices
 - Type Approval information

Tools available:

- VISTA – legislation database

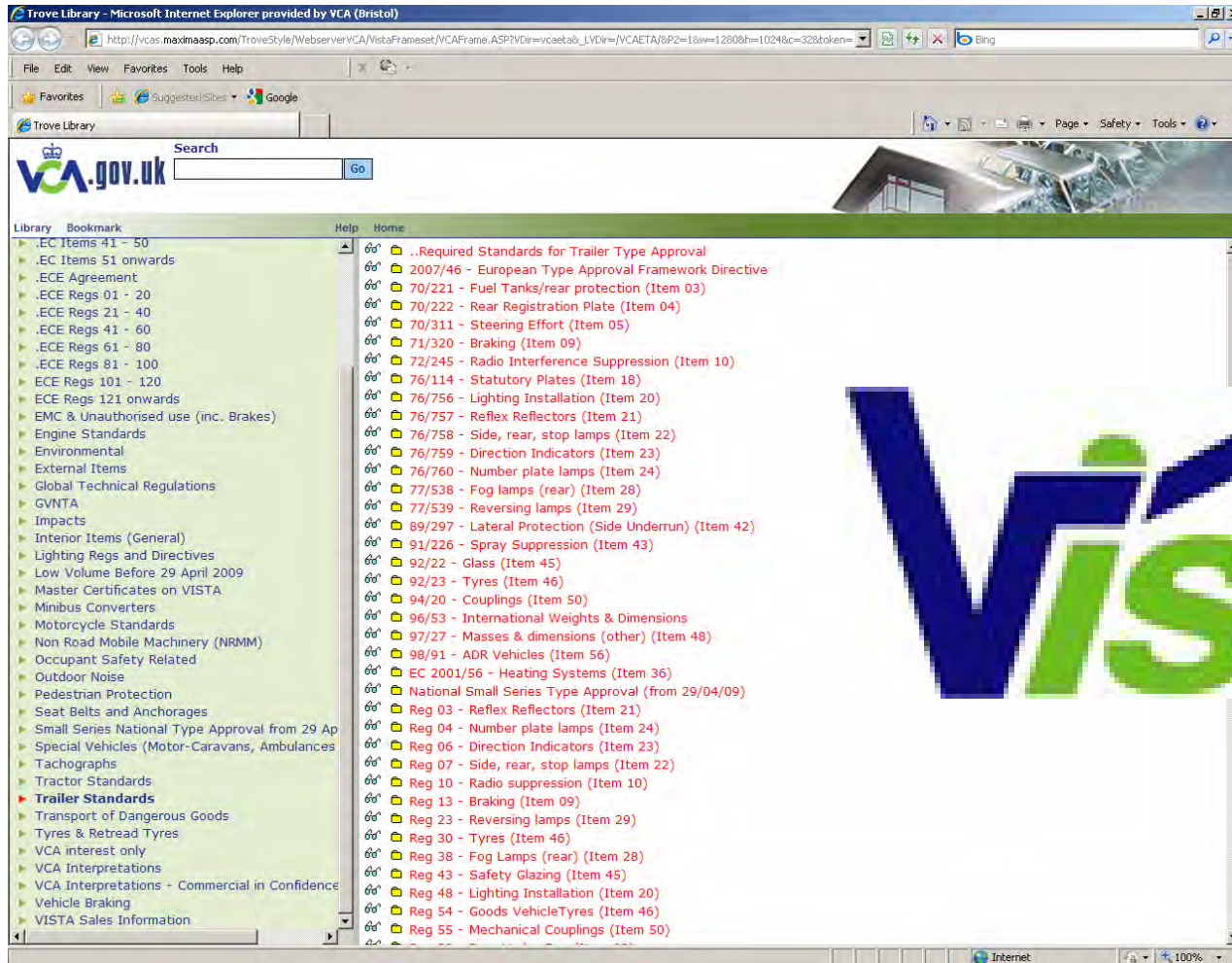

The screenshot shows the VISTA legislation database interface. The browser window title is "Trove Library - Microsoft Internet Explorer provided by VCA (Bristol)". The address bar contains the URL: <http://vcas.maximaasp.com/TroveStyle/WebsserverVCA/VistaFrameset/VCAFrame...>. The page header includes the VCA.gov.uk logo and a search bar. The main content area is a list of legislative items, with a left-hand navigation menu. The list includes:

- ..Required Standards for Trailer Type Approval
- 2007/46 - European Type Approval Framework Directive
- 70/221 - Fuel Tanks/rear protection (Item 03)
- 70/222 - Rear Registration Plate (Item 04)
- 70/311 - Steering Effort (Item 05)
- 71/320 - Braking (Item 09)
- 72/245 - Radio Interference Suppression (Item 10)
- 76/114 - Statutory Plates (Item 18)
- 76/756 - Lighting Installation (Item 20)
- 76/757 - Reflex Reflectors (Item 21)
- 76/758 - Side, rear, stop lamps (Item 22)
- 76/759 - Direction Indicators (Item 23)
- 76/760 - Number plate lamps (Item 24)
- 77/538 - Fog lamps (rear) (Item 28)
- 77/539 - Reversing lamps (Item 29)
- 89/297 - Lateral Protection (Side Underrun) (Item 42)
- 91/226 - Spray Suppression (Item 43)
- 92/22 - Glass (Item 45)
- 92/23 - Tyres (Item 46)
- 94/20 - Couplings (Item 50)
- 96/53 - International Weights & Dimensions
- 97/27 - Masses & dimensions (other) (Item 49)
- 98/91 - ADR Vehicles (Item 56)
- EC 2001/56 - Heating Systems (Item 36)
- National Small Series Type Approval (from 29/04/09)
- Reg 03 - Reflex Reflectors (Item 21)
- Reg 04 - Number plate lamps (Item 24)
- Reg 06 - Direction Indicators (Item 23)
- Reg 07 - Side, rear, stop lamps (Item 22)
- Reg 10 - Radio suppression (Item 10)
- Reg 13 - Braking (Item 09)
- Reg 23 - Reversing lamps (Item 29)
- Reg 30 - Tyres (Item 46)
- Reg 38 - Fog Lamps (rear) (Item 28)
- Reg 43 - Safety Glazing (Item 45)
- Reg 48 - Lighting Installation (Item 20)
- Reg 54 - Goods Vehicle Tyres (Item 46)
- Reg 55 - Mechanical Couplings (Item 50)

Tools available:

- **CMS – Compliance Management System**

What is CMS?

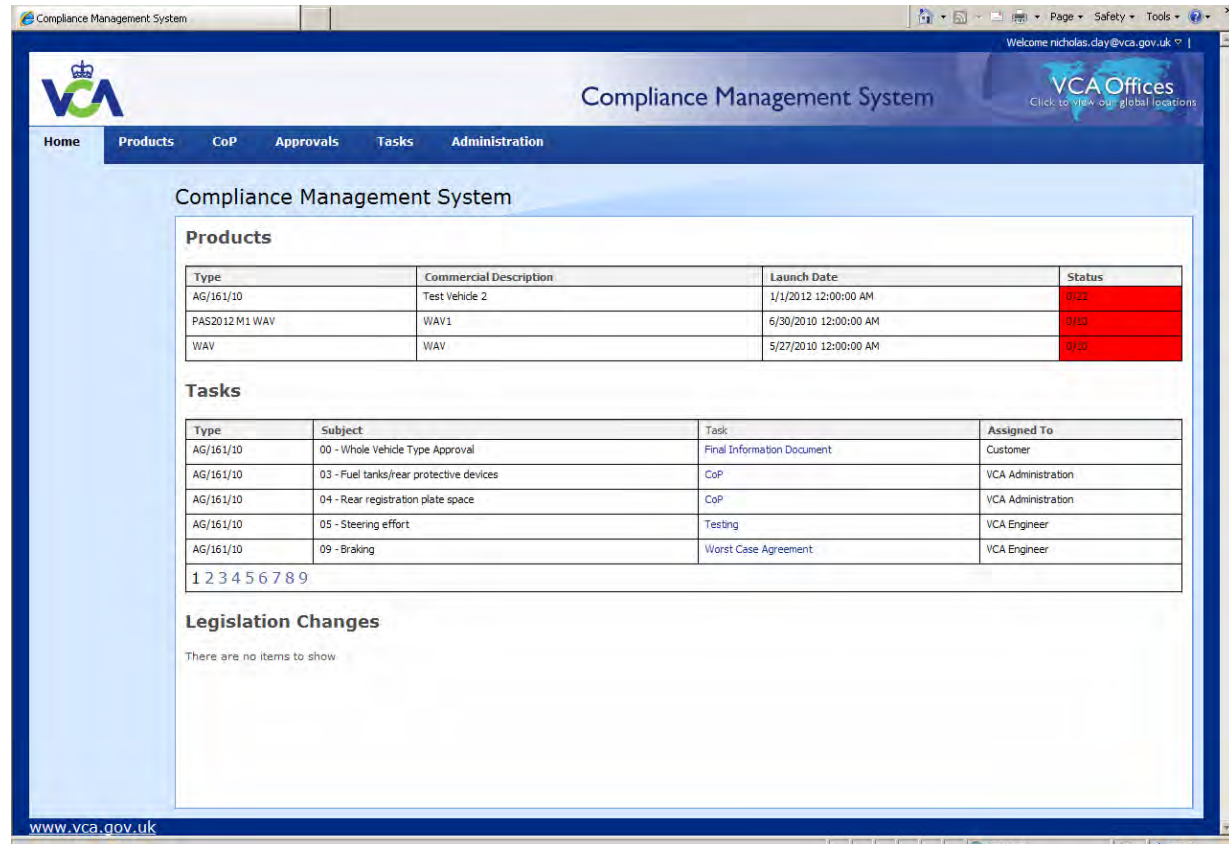

Compliance Management System

Welcome richolas.day@vca.gov.uk

VCA Offices
Click to view our global locations

Home Products CoP Approvals Tasks Administration

Compliance Management System

Products

Type	Commercial Description	Launch Date	Status
AG/161/10	Test Vehicle 2	1/1/2012 12:00:00 AM	0/22
PAS2012 M1 WAV	WAV1	6/30/2010 12:00:00 AM	0/10
WAV	WAV	5/27/2010 12:00:00 AM	0/10

Tasks

Type	Subject	Task	Assigned To
AG/161/10	00 - Whole Vehicle Type Approval	Final Information Document	Customer
AG/161/10	03 - Fuel tanks/rear protective devices	CoP	VCA Administration
AG/161/10	04 - Rear registration plate space	CoP	VCA Administration
AG/161/10	05 - Steering effort	Testing	VCA Engineer
AG/161/10	09 - Braking	Worst Case Agreement	VCA Engineer

1 2 3 4 5 6 7 8 9

Legislation Changes

There are no items to show

www.vca.gov.uk

- VCA's web based collaborative system
 - Helping manufacturers manage their type approval process

How does CMS help?

- Guidance through the type approval process
- Exchange type approval documentation
- Exchange supporting data
- Track the type approval process and monitor progress

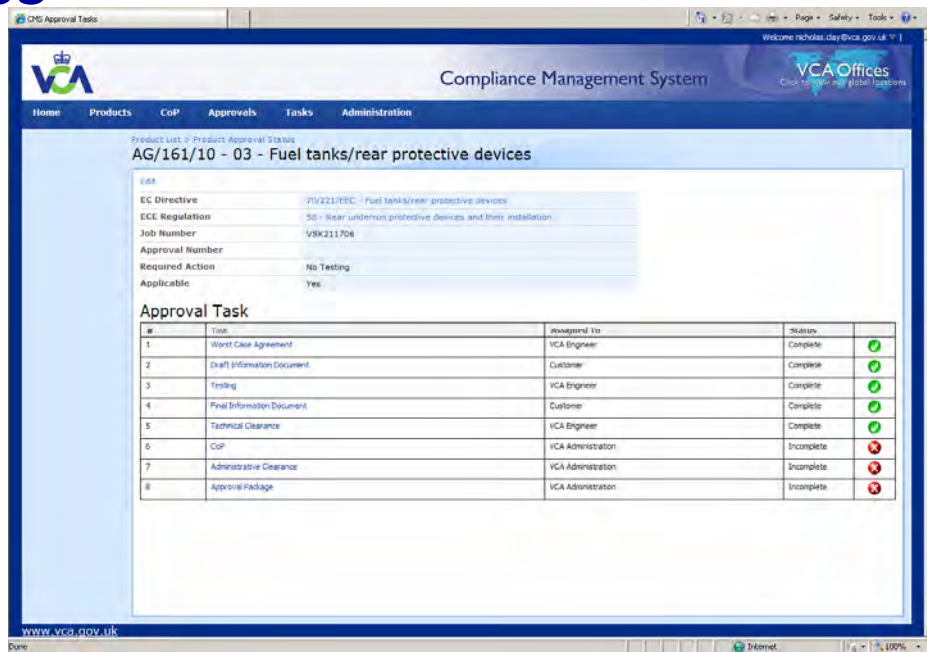

The screenshot displays the 'CMS Approval Tasks' interface. At the top, there is a navigation menu with 'Home', 'Products', 'CoP', 'Approvals', 'Tasks', and 'Administration'. The main content area shows the 'Product List > Product Approval Status' for 'AG/161/10 - 03 - Fuel tanks/rear protective devices'. Below this, there is a table of metadata including EC Directive (75/221/EEC), ECE Regulation (55), Job Number (VSK211706), and Required Action (No Testing). A section titled 'Approval Task' contains a table with the following data:

#	Task	Assigned To	Status	Progress
1	Work Case Agreement	VCA Engineer	Complete	✓
2	Draft Information Document	Customer	Complete	✓
3	Testing	VCA Engineer	Complete	✓
4	Final Information Document	Customer	Complete	✓
5	Technical Clearance	VCA Engineer	Complete	✓
6	CoP	VCA Administration	Incomplete	✗
7	Administrative Clearance	VCA Administration	Incomplete	✗
8	Approval Package	VCA Administration	Incomplete	✗

How does CMS help?

- Allows manufacturers to:
 - Receive alerts and prompts for information and documents to be supplied to VCA
 - Securely store and have easy access to all completed approvals
 - Store and keep track of Conformity of Production (CoP) documentation

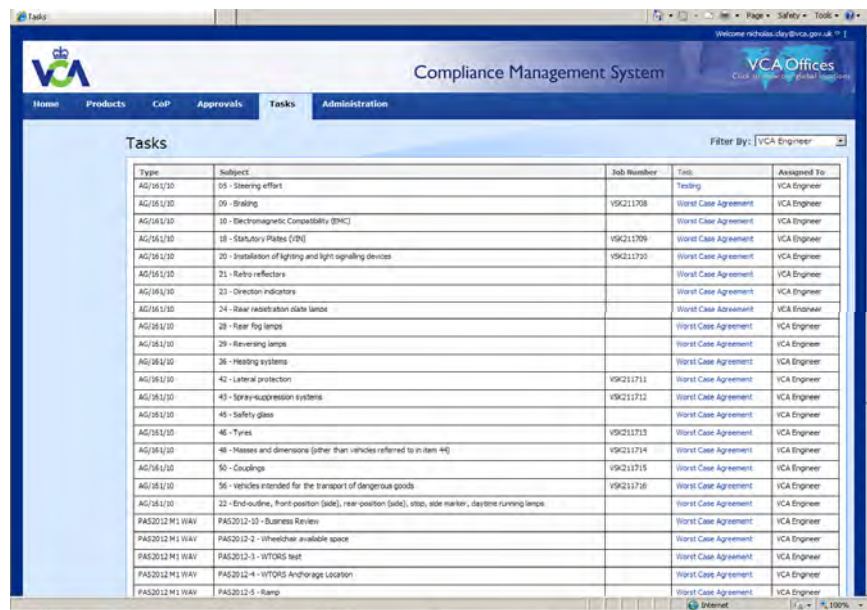

The screenshot displays the VCA Compliance Management System (CMS) interface. The page title is "Compliance Management System" and the user is logged in as "nicholas.dley@vca.gov.uk". The navigation menu includes "Home", "Products", "CoP", "Approvals", "Tasks", and "Administration". The "Tasks" section is active, showing a list of tasks assigned to a VCA Engineer. The table below represents the data shown in the screenshot.

Type	Subject	Job Number	Task	Assigned To
AG/16/1/20	95 - Steering effort		Testing	VCA Engineer
AG/16/1/20	99 - Braking	V9K211708	Worst Case Agreement	VCA Engineer
AG/16/1/20	10 - Electromagnetic Compatibility (EMC)		Worst Case Agreement	VCA Engineer
AG/16/1/20	18 - Statutory Plates (SP)	V9K211709	Worst Case Agreement	VCA Engineer
AG/16/1/20	20 - Installation of lighting and light signalling devices	V9K211710	Worst Case Agreement	VCA Engineer
AG/16/1/20	21 - Retro reflectors		Worst Case Agreement	VCA Engineer
AG/16/1/20	23 - Direction indicators		Worst Case Agreement	VCA Engineer
AG/16/1/20	24 - Rear redistribution date lamps		Worst Case Agreement	VCA Engineer
AG/16/1/20	28 - Rear fog lamps		Worst Case Agreement	VCA Engineer
AG/16/1/20	29 - Reversing lamps		Worst Case Agreement	VCA Engineer
AG/16/1/20	36 - Heating systems		Worst Case Agreement	VCA Engineer
AG/16/1/20	42 - Lateral protection	V9K211711	Worst Case Agreement	VCA Engineer
AG/16/1/20	43 - Sprinkler-suppression systems	V9K211712	Worst Case Agreement	VCA Engineer
AG/16/1/20	45 - Safety glass		Worst Case Agreement	VCA Engineer
AG/16/1/20	46 - Tyres	V9K211713	Worst Case Agreement	VCA Engineer
AG/16/1/20	48 - Masses and dimensions (other than vehicles referred to in item 44)	V9K211714	Worst Case Agreement	VCA Engineer
AG/16/1/20	50 - Couplings	V9K211715	Worst Case Agreement	VCA Engineer
AG/16/1/20	56 - Vehicles intended for the transport of dangerous goods	V9K211716	Worst Case Agreement	VCA Engineer
AG/16/1/20	22 - End-outline, front-position (side), rear-position (side), vltos, side marker, daytime running lamps		Worst Case Agreement	VCA Engineer
FA52012 M1 VAV	FA52012-10 - Business Review		Worst Case Agreement	VCA Engineer
FA52012 M1 VAV	FA52012-2 - Wheelchair available space		Worst Case Agreement	VCA Engineer
FA52012 M1 VAV	FA52012-3 - VTDOS test		Worst Case Agreement	VCA Engineer
FA52012 M1 VAV	FA52012-4 - VTDOS Anchorage Location		Worst Case Agreement	VCA Engineer
FA52012 M1 VAV	FA52012-5 - Ramp		Worst Case Agreement	VCA Engineer

- Questions?
- Nicholas.Clay@vca.gov.uk
- 01179524136

- Costs?
- Audit: £800-1600 (1-2 days)
- Paperwork clearance: £250

Support & Information Sources

- VCA website - www.dft.gov.uk/vca
- Address: VCA Midlands Centre
Watling Street
Nuneaton
Warwickshire
CV10 0UA
- Telephone: 0247 632 8421