

ANNEX 7

STABILITY OF MULTIHULL CRAFT

The term "multihull craft" is defined in 2.1.3.4 of the Code.

1 Stability criteria in the intact condition

A multihull craft, in the intact condition, shall have sufficient stability when rolling in a seaway to successfully withstand the effect of either passenger crowding or high-speed turning as described in 1.4. The craft's stability shall be considered to be sufficient provided compliance with this paragraph is achieved.

1.1 Area under the GZ curve

The area (A_1) under the GZ curve up to an angle θ shall be at least:

$$A_1 = 0.055 \times 30^\circ / \theta \quad (\text{m.rad})$$

where θ is the least of the following angles:

- .1 the downflooding angle;
- .2 the angle at which the maximum GZ occurs; and
- .3 30° .

1.2 Maximum GZ

The maximum GZ value shall occur at an angle of at least 10° .

1.3 Heeling due to wind

Paragraph 1.3 of this annex contains no actual criteria. An intact stability criterion for angle of heel due to a steady wind is however given in 3.2.1 of this annex.

The wind heeling lever shall be assumed constant at all angles of inclination and shall be calculated as follows:

$$HL_1 = \frac{P_i \cdot A \cdot Z}{9800\Delta} \quad (\text{m})$$

$$HL_2 = 1.5 HL_1 \quad (\text{m}) \quad (\text{see figure 1})$$

where:

$$P_i = 500 (V_w / 26)^2 \quad (\text{N/m}^2)$$

V_w = wind speed corresponding to the worst intended conditions (m/s)

A = projected lateral area of the portion of the craft above the lightest service waterline (m^2)

Z = vertical distance from the centre of A to a point one half the lightest service draught (m)

Δ = displacement (t).

1.4 Heeling due to passenger crowding or high-speed turning

Paragraph 1.4 of this annex contains no actual criteria, but the data derived are required in the application of 1.5 below, using the heeling levers listed in 3.1 of this annex.

Heeling due to the crowding of passengers on one side of the craft or to high-speed turning, whichever is the greater, shall be applied in combination with the heeling lever due to wind (HL₂).

1.4.1 Heeling due to passenger crowding

When calculating the magnitude of the heel due to passenger crowding, a passenger crowding lever shall be developed using the assumptions stipulated in 2.10 of this Code.

1.4.2 Heeling due to high-speed turning

When calculating the magnitude of the heel due to the effects of high-speed turning, a high-speed turning lever shall be developed using either the following formula or an equivalent method specifically developed for the type of craft under consideration, or trials or model test data:

$$TL = \frac{I}{g} \frac{V_o^2}{R} \left(KG - \frac{d}{2} \right) \quad (\text{m})$$

where:

TL = turning lever (m)

V_o = speed of craft in the turn (m/s)

R = turning radius (m)

KG = height of vertical centre of gravity above keel (m)

d = mean draught (m)

g = acceleration due to gravity.

It should be noted that this method is extremely simplistic and often pessimistic because it ignores hydrodynamic forces on the hull and appendages. Alternatively, another method of assessment may be employed, as provided for in 2.1.4 of this Code.

1.5 Rolling in waves (figure 1)

The effect of rolling in a seaway upon the craft's stability shall be demonstrated mathematically. In doing so, the residual area under the GZ curve (A₂), i.e. beyond the angle of heel (θ_h), shall be at least equal to 0.028 m.rad up to the angle of roll θ_r . In the absence of model test or other data, θ_r shall be taken as 15° or an angle of ($\theta_d - \theta_h$), whichever is less.

The determination of θ_r using model test or full-scale data should be made using the method for determining θ_z in 1.1.5.3 of annex 6.

2 Criteria for residual stability after damage

It is helpful to read 2.5 and 2.6 of this annex before proceeding further.

Paragraph 2.2 of this annex contains no actual criteria. A damaged stability criterion for angle of heel due to a steady wind is however given in 3.2.2 of this annex.

2.1 The method of application of criteria to the residual stability curve is similar to that for intact stability except that the craft in the final condition after damage shall be considered to have an adequate standard of residual stability provided:

- .1 the required area A_2 shall be not less than 0.028 m.rad (figure 2 refers); and
- .2 there is no requirement regarding the angle at which the maximum GZ value shall occur.

2.2 The wind heeling lever for application on the residual stability curve shall be assumed constant at all angles of inclination and shall be calculated as follows:

$$HL_3 = \frac{P_d \cdot A \cdot Z}{9800\Delta}$$

where:

$$P_d = 120 (V_w / 26)^2 \quad (\text{N/m}^2)$$

V_w = wind speed corresponding to the worst intended conditions (m/s)

A = projected lateral area of the portion of the ship above the lightest service waterline (m^2)

Z = vertical distance from the centre of A to a point one half of the lightest service draught (m)

Δ = displacement (t).

2.3 The same values of roll angle shall be used as for the intact stability.

The intact stability roll angle is described in 1.5 of this annex.

2.4 The downflooding point is important and is regarded as terminating the residual stability curve. The area A_2 shall therefore be truncated at the downflooding angle.

2.5 The stability of the craft in the final condition after damage shall be examined and shown to satisfy the criteria, when damaged as stipulated in 2.6 of this Code.

2.6 In the intermediate stages of flooding, the maximum righting lever shall be at least 0.05 m and the range of positive righting lever shall be at least 7° . In all cases, only one breach in the hull and only one free surface need to be assumed.

3 Application of heeling levers

3.1 In applying the heeling levers to the intact and damaged curves, the following shall be considered:

.1 for intact condition:

.1.1 wind heeling lever (including gusting effect) (HL_2); and

.1.2 wind heeling lever (including gusting effect) plus either the passenger crowding or speed turning levers whichever is the greater (HTL);

.2 for damage condition:

.2.1 wind heeling lever - steady wind (HL_3); and

.2.2 wind heeling lever plus heeling lever due to passenger crowding (HL_4).

3.2 Angles of heel due to steady wind

3.2.1 The angle of heel due to a wind gust when the heeling lever HL_2 , obtained as in 1.3, is applied to the intact stability curve shall not exceed 10° .

3.2.2 The angle of heel due to a steady wind when the heeling lever HL_3 , obtained as in 2.2, is applied to the residual stability curve after damage, shall not exceed 15° for passenger craft and 20° for cargo craft.

MULTIHULL CRAFT CRITERIA

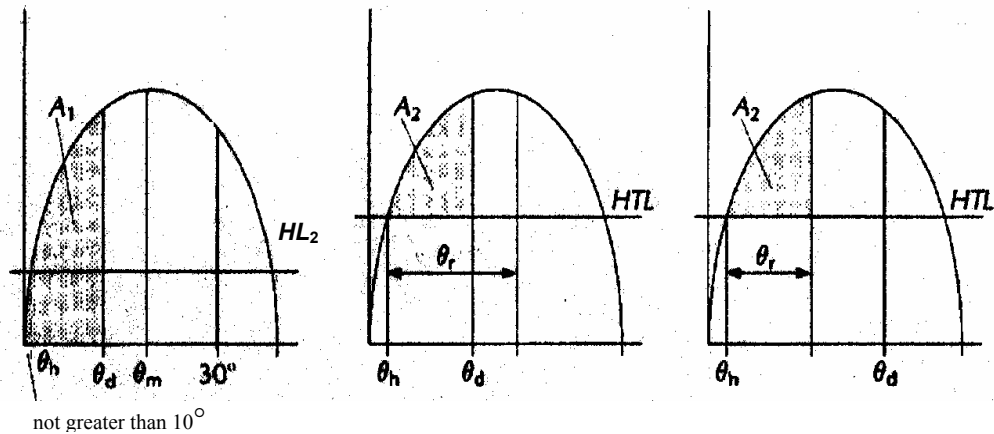

Figure 1 - Intact stability

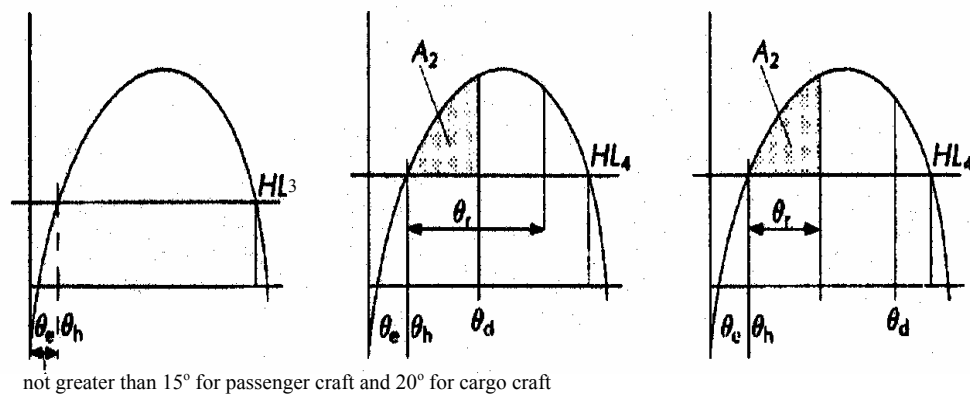

Figure 2 - Damage stability

Abbreviations used in figures 1 and 2

- HL₂ = Heeling lever due to wind + gusting
- HTL = Heeling lever due to wind + gusting + (passenger crowding or turning)
- HL₃ = Heeling lever due to wind
- HL₄ = Heeling lever due to wind + passenger crowding
- θ_m = Angle of maximum GZ
- θ_d = Angle of downflooding
- θ_r = Angle of roll
- θ_e = Angle of equilibrium, assuming no wind, passenger crowding or turning effects
- θ_h = Angle of heel due to heeling lever HL₂, HTL, HL₃ or HL₄
- A₁ ≥ Area required by 1.1
- A₂ ≥ 0.028 m.rad