

**The Merchant Shipping (Cargo Ship Construction) Regulations 1997:  
Schedules**

This Notice forms an integral part of the Merchant Shipping (Cargo Ship Construction) Regulations 1997 and Schedules referred to in the Notice are those invoked in those Regulations. Compliance with its provisions is therefore a statutory obligation.

**Notice to all Shipowners, Shipbuilders, Masters, Certifying Authorities and Surveyors**

- Schedule 1: Ballast and bilge pumping and drainage arrangements
- Schedule 2: Cargo tank venting arrangements
- Schedule 3: The design, construction, location and testing of devices to prevent the passage of flame into cargo tanks in oil tankers
- Part 1 Definitions
  - Part 2 Design
  - Part 3 Construction
  - Part 4 Performance tests (General)
  - Part 5 Test procedures for flame screens and flame arrestors
  - Part 6 Test procedures for high velocity vents
  - Part 7 Test procedures for flame arrestors located in-line
  - Part 8 Location and installation of devices
  - Part 9 Manufacturer's instruction manual
- Schedule 4: Storage and distribution of oil and gaseous fuel
- Part 1 Fuel
  - Part 2 Lubricating and other oil systems
  - Part 3 Arrangements for oil fuel systems
- Schedule 5: Remote control of propulsion machinery from the navigating bridge
- Schedule 6: Steering gears
- Part 1 General
  - Part 2 Electric and electro-hydraulic steering gear
  - Part 3 Steering gear in tankers
- Schedule 7: Construction of rudder actuators for certain tankers
- Schedule 8: Protection against noise
- Schedule 9: Periodically unattended machinery spaces
- Schedule 10: Emergency and transitional source of electrical power

Part 1	Emergency and transitional source of electrical power
Part 2	Starting arrangements for emergency generating sets
Part 3	Emergency supplies

Schedule 11: General precautions against shock, fire and other hazards

Schedule 12: Electrical equipment in hazardous areas and spaces

Schedule 13: Emergency towing arrangements for tankers

In this Merchant Shipping Notice –

- (1) a reference to a numbered paragraph is, unless otherwise stated, a reference to the paragraph of that number in the Schedule;
- (2) a reference to a numbered section is, unless otherwise stated, a reference to the section of that number in that Part;
- (3) a reference to a numbered Part is, unless otherwise stated, a reference to the Part of that number in that Schedule;
- (4) a reference to a numbered Schedule is, unless otherwise stated, a reference to the Schedule of that number in this Merchant Shipping Notice;
- (5) where a sub-heading refers to "requirements" or to "additional requirements" for certain ships, the text following such a subheading in that Part or Schedule (or until the next sub-heading in that Part or Schedule) shall (unless the context otherwise requires) relate only to such ships;
- (6) a reference to a ship constructed on or after a specified date is a reference to a ship the keel of which is laid or which is at a similar stage of construction on or after that date.

In this Merchant Shipping Notice –

"accommodation spaces" means passenger spaces, corridors, lavatories, cabins, offices, crew spaces, hairdressing salons, pantries not containing cooking appliances, lockers and similar spaces;

"auxiliary steering gear" means the equipment, other than any part of the main steering gear, necessary to steer the ship in the event of failure of the main steering gear but not including the tiller, quadrant or components serving the same purpose;

"bulkhead deck" means the deck up to which the majority of transverse watertight bulkheads are carried;

"cargo ship" means a mechanically propelled ship which is not a passenger ship, troop ship, pleasure vessel or fishing vessel;

"cargo spaces" means all spaces used for cargo, including cargo tanks, and trunks to such spaces;

"Certifying Authority" means the Secretary of State or any person authorised by the Secretary of State and includes in particular (if so authorised) Lloyd's Register of Shipping, the British Committee of the Bureau Veritas, the British Committee of Det Norske Veritas, the British Committee of Germanischer Lloyd, and the British Technical Committee of the American Bureau of Shipping;

"chemical tanker" means a tanker constructed or adapted and used for the carriage in bulk of any liquid power product of a flammable nature listed in Chapter 17 of the International Code for the Construction and Equipment of Ships Carrying Dangerous Chemicals in Bulk;

"control stations" means spaces in which radio or main navigating equipment, or the emergency source of power, or the central fire recording, or fire control equipment, or fire extinguishing installations are located or a control room located outside a propelling machinery space;

"dangerous goods" means goods defined as such in the Merchant Shipping (Dangerous Goods and Marine Pollutants) Regulations 1990 <sup>(a)</sup>;

"deadweight" means the difference in tonnes between the displacement of a ship at the summer load waterline in water of a specific gravity of 1.025 and the lightweight of the ship;

"emergency source of electrical power" means a source of electrical power intended to supply the emergency switchboard in the event of failure of the supply from the main source of electrical power;

"emergency switchboard" means a switchboard which in the event of failure of the main electrical power supply system is directly supplied by the emergency source of electrical power or the transitional source of emergency power and is intended to distribute electrical energy to the emergency services;

"freeboard deck" means the deck defined as such in the Merchant Shipping (Load Line) Rules 1968 <sup>(b)</sup>;

"gas carrier" means a tanker constructed or adapted and used for the carriage in bulk of any liquefied gas or certain other substances of a flammable nature listed in Chapter 19 of the International Code for the Construction and Equipment of Ships Carrying Liquefied Gases in Bulk;

"hazardous area" means an area in which explosive gas-air mixtures are, or may be expected to be, present in quantities such as to require special precautions for the construction and use of electrical apparatus or other apparatus which otherwise would constitute a source of ignition;

"lightweight" means the displacement of a ship in tonnes without cargo, fuel, lubricating oil, ballast water, feed water and fresh water in tanks, consumable stores, passengers and crew and their effects;

"machinery alarm and control centre" means the position from which the propelling and auxiliary machinery can be controlled and where the alarms other than those located in accommodation spaces and at the navigating bridge, necessary for the safe operation of such machinery are located;

"machinery control room" means a room from which the propelling machinery and boilers serving the needs of propulsion may be controlled;

"machinery space" means any space which contains propelling machinery, boilers, oil fuel units, steam and internal combustion engines, generators and major electrical machinery, oil filling stations, refrigerating, stabilising, ventilation and air conditioning machinery, and similar spaces; and, where the context so admits, any trunk to such a space;

---

<sup>a</sup> SI 1990/2605, to which there is an amendment not relevant to this Notice.

<sup>b</sup> SI 1968/1053, to which there are amendments not relevant to these Regulations.

"machinery spaces of Category A' means a machinery space which contains -

(a) internal combustion type machinery used either for main propulsion purposes, or for other purposes where such machinery has in the aggregate a total power output of not less than 375 kilowatts; or

(b) any oil fired boiler or oil fuel unit;

and any trunk to such a space;

"main generating station" means the space in which the main source of electrical power is situated;

"main source of electrical power" means a source intended to supply electrical power to the main switchboard for distribution to all services necessary for maintaining a ship in normal operational and habitable conditions;

"main steering gear" means the machinery, rudder actuators, steering gear power units, if any, and auxiliary equipment and the means of applying torque to the rudder stock, such as the tiller or quadrant, necessary for effecting movement of the rudder for the purpose of steering the ship under normal service conditions;

"main switchboard" means the switchboard which is directly supplied by the main source of electrical power and is intended to distribute electrical energy to the ship's services;

"Marine Safety Agency" means the Marine Safety Agency, an Executive Agency of the Department of Transport;

"maximum ahead service speed" means the greatest speed which the ship is designed to maintain at sea at her deepest seagoing draught;

"maximum astern speed" means the greatest speed which it is estimated the ship can attain at the designed maximum astern power at the deepest sea going draught;

"Merchant Shipping Notice" means a Notice described as such, issued by the Department of Transport; and includes a reference to any document amending or replacing that Notice which is considered by the Secretary of State to be relevant from time to time and is specified in a Merchant Shipping Notice;

"navigable speed" means the minimum speed at which the ship can be effectively steered in the ahead direction;

"noise level" means 'A' weighted sound pressure level in decibels dB(A) as defined and tabulated in the British Standards specification number BS EN 60651;1994 Specifications for Sound Level Meters;

"normal operational and habitable condition" is a condition under which the ship as a whole, the machinery, services, means and aids ensuring propulsion, ability to steer, safe navigation, fire and flooding safety, internal and external communications and signals, means of escape and emergency boat winches, as well as the designed comfortable conditions of habitability are in working order and functioning normally;

"oil fuel unit" means the equipment used for the preparation of oil fuel for delivery to an oil fired boiler or equipment used for the preparation for delivery of heated oil to an internal combustion engine and includes any oil pressure pumps, filters and heaters dealing with oil at a pressure greater than 180 kPa;

"oil tanker" means a ship constructed or adapted primarily to carry oil in bulk in its cargo spaces and includes a combination carrier or a chemical tanker when it is carrying a cargo or part cargo of oil in bulk;

"pleasure vessel" means

**(a)** any vessel which at the time it is being used is –

**(i)** **(a)** in the case of a vessel wholly owned by an individual or individuals used only for the sport or pleasure of the owner or the immediate family or friends of the owner; or

**(b)** in the case of a vessel owned by a body corporate, used only for sport or pleasure and on which the persons are employees or officers of the body corporate, or their immediate family or friends; and

**(ii)** on a voyage or excursion which is one for which the owner does not receive money for or in connection with operating the vessel or carrying any person, other than as a contribution to the direct expenses of the operation of the vessel incurred during the voyage or excursion; or

**(b)** any vessel wholly owned by or on behalf of a members' club formed for the purpose of sport or pleasure which, at the time it is being used, is used only for the sport or pleasure of members of that club or their immediate family; and for the use of which any charges levied are paid into club funds and applied for the general use of the club; and

**(c)** in the case of any vessel referred to in paragraphs (a) or (b) above no other payments are made by or on behalf of users of the vessel, other than by the owner.

In this definition "immediate family" means in relation to an individual, the husband or wife of the individual, and a relative of the individual or the individual's husband or wife, and "relative" means brother, sister, ancestor or lineal descendant;

"power actuating system" means the hydraulic equipment provided for supplying power to turn the rudder stock, comprising a steering gear power unit or units, together with the associated pipes and fittings, and a rudder actuator. The power actuating systems may share common mechanical components, that is, tiller, quadrant and rudder stock or components serving the same purpose;

"Reid vapour pressure" means the vapour pressure of a liquid as determined by laboratory testing in a standard manner in the Reid apparatus;

"a similar stage of construction" means a stage at which -

**(a)** construction identifiable with a specific ship begins; and

**(b)** assembly of that ship, comprising at least 50 tonnes or 1 per cent of the estimated mass of all structural material, whichever is the less, has commenced;

"settling tank" means an oil storage tank having a heating surface of not less than 0.183 square metre per tonne of oil capacity;

"steering gear control system" means the equipment by which orders are transmitted from the navigating bridge to the steering gear power units. Steering gear control systems comprise transmitters, receivers, hydraulic control pumps and their associated motors, motor controllers, piping and cables;

"steering gear power unit" means -

(a) in the case of electric steering gear, the electric motor and its associated electric equipment; or

(b) in the case of electro-hydraulic steering gear, the electric motor, its associated electrical equipment and connected pump; or

(c) in the case of steam-hydraulic or pneumatic-hydraulic steering gear, the driving engine and connected pump;

"suitable" in relation to material means accepted by the Marine Safety Agency as suitable for the purpose for which it is used;

"Surveyor" means a surveyor appointed by a Certifying Authority;

"tanker" means a cargo ship constructed or adapted for the carriage in bulk of liquid cargoes of a flammable nature and except where the context otherwise requires, includes a gas carrier and a chemical tanker;

"tons" means gross tons and a reference to tons -

(a) in relation to a ship having alternative gross tonnages under paragraph 13 of Schedule 5 of the Merchant Shipping (Tonnage) Regulations 1982<sup>(a)</sup> is a reference to the larger of those tonnages; and

(b) in relation to a ship having its tonnage determined both under Part II and regulation 16 of those Regulations is a reference to its gross tonnage as determined under regulation 16 of those Regulations;

"watertight" means capable of preventing the passage of water in any direction;

MSAS (D)  
Marine Safety Agency  
Spring Place  
105 Commercial Road  
Southampton  
SO15 1EG

Telephone: 01703 329195  
Fax: 01703 329204

20 March 1997

**SAFE SHIPS CLEAN SEAS**

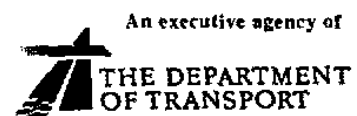

---

<sup>a</sup> S.I. 1982/841

**SCHEDULE 1**

**BALLAST AND BILGE PUMPING AND DRAINAGE ARRANGEMENTS**

1. Every ship shall be provided with efficient bilge pumping plant and means for drainage so arranged that water entering any part of the hull, up to the bulkhead deck, other than a space permanently appropriated for the carriage of fresh water, water ballast, oil fuel or liquid cargo and for which other efficient means of pumping or drainage are provided, can be pumped out through at least one suction pipe when the ship is on an even keel or is listed not more than 5 degrees either way. Wing suctions shall be provided where necessary for this purpose. Efficient means shall be provided whereby water may easily flow to the suction pipes; provided that the Certifying Authority may allow the means of pumping or drainage to be dispensed with in particular compartments of any ship, if it is satisfied that the safety of the ship is not thereby impaired.

***Additional requirements for ships constructed on or after 25th May 1980***

2. Provision shall be made for the drainage of enclosed cargo spaces situated on the freeboard deck of any ship; provided that the Certifying Authority may permit the means of drainage to be dispensed with in any particular compartments of any ship if by reasons of the size or internal subdivision of those spaces, the safety of the ship is not thereby impaired. Where the freeboard is such that the deck edge is not immersed when the ship heels 5 degrees either way, the required drainage shall be by means of a suitable number and size of deck scuppers discharging directly overboard fitted in accordance with paragraph 12 of Schedule 4 of the Merchant Shipping (Load Line) Rules 1968. In all other cases, internal drainage shall be led to a suitable space or spaces of adequate capacity, having a high water-level alarm and provided with suitable arrangements for discharge overboard.

***Additional requirements for ships constructed on or after 1st September 1984***

3. At least two power pumps connected to the main bilge system shall be provided, one of which may be driven by the propulsion machinery. Sanitary, ballast and general service pumps may be accepted as power bilge pumps if provided with the **necessary connections to the bilge pumping system**.

4. All bilge pipes used in or under coal bunkers or fuel storage tanks or in machinery spaces shall be of steel or other suitable material.

5. The bilge and ballast pumping systems shall be so arranged as to prevent water passing from the sea or from water ballast spaces into the cargo spaces or into the machinery spaces or from one watertight compartment to another. Provision shall be made to prevent any deep tank having bilge and ballast connections being inadvertently flooded from the sea when it contains cargo or being discharged through a bilge pipe when it contains water ballast.

6. The distribution boxes and manually operated valves provided in connection with the bilge pumping arrangements shall be in positions which are accessible under ordinary circumstances. The valves shall be clearly marked for identification.

7. The scuppers of cargo spaces intended for the carriage of motor vehicles with fuel in their tanks for their own propulsion shall not be led to machinery or other spaces where sources of ignition may be present.

8. The bilge pumping arrangements for cargo spaces intended to contain flammable or toxic liquids shall be designed so that inadvertent pumping of such liquids through the main bilge system or any other system connected to a pump located in a machinery space can be prevented. Additional means of draining such spaces shall be provided if the Certifying Authority considers their provision necessary taking into consideration the quantity and characteristics of the liquids and their location.

***Additional requirements for ships constructed on or after 1st February 1992***

9. Where the freeboard is such that the edge of the freeboard deck is immersed when the ship heels 5 degrees or less, the drainage of the enclosed cargo spaces on the freeboard deck required by paragraph 2 shall be led to a suitable space, or spaces, of adequate capacity, having a high water level alarm and provided with suitable arrangements for discharge overboard. In addition it shall be ensured that -

- (a) the number, size and disposition of the scuppers are such as to prevent unreasonable accumulation of free water;
- (b) the pumping arrangements take account of the requirements for any fixed pressure water-spraying fire-extinguishing system;
- (c) water contaminated with petrol or other dangerous substances is not drained to machinery spaces or other spaces where sources of ignition may be present or where it could pose a health and safety hazard to persons; and
- (d) where the enclosed cargo space is protected by a carbon dioxide fire-extinguishing system the deck scuppers are fitted with means to prevent the escape of the smothering gas.

***Regulation 23***

**SCHEDULE 2**

**CARGO TANK VENTING ARRANGEMENTS**

1. The cargo tank venting arrangements shall -

- (a) be so designed and constructed as to ensure that the pressure, above or below that of the atmosphere, within the tanks does not exceed the design pressures;
- (b) include pressure-vacuum valves capable of providing for the flow of vapour, air or inert gas mixtures caused by thermal variations within the cargo tank; and
- (c) be capable of providing for the flow of vapour, air or inert gas mixtures whilst the tank is being loaded, ballasted or discharged at the highest rate.

2. Every vent system outlet to atmosphere from a valve required by subparagraph 1(b) shall be located as high and at the furthest distance from a source of ignition as is practicable and in no case shall it be located less than 2 metres above the cargo tank deck or less than 5 metres from air intakes or openings to enclosed spaces containing a source of ignition or from machinery and equipment which may constitute an ignition hazard.

**3.** By-pass arrangements for the pressure-vacuum valves required by subparagraph 1(b) may be fitted if the valves are located in a vent main or masthead riser. Indicators showing whether the by-pass is open or shut shall be provided.

**4.** Every vent system outlet to atmosphere provided in accordance with subparagraph 1(c) shall

**(a)** permit the free flow of vapour mixtures, or be so designed that the discharge velocity of the vapour mixtures is at least 30 metres per second;

**(b)** be so arranged that the vapour mixture is discharged vertically upwards;

**(c)** where the system permits the free flow of vapour mixtures, be such that the outlets to atmosphere are located at least 6 metres above the cargo tank deck and at least 10 metres measured horizontally, from the nearest air intake or opening to an enclosed space containing a source of ignition and from machinery and equipment which may constitute an ignition hazard. Any outlet less than 4 metres, measured horizontally, from a fore and aft gangway shall be located at least 6 metres above the gangway;

**(d)** where the system is so designed that the discharge velocity of the vapour mixtures is at least 30 metres per second, be such that the outlets to atmosphere are located at least 2 metres above the cargo tank deck and at least 10 metres, measured horizontally, from the nearest air intake or opening to an enclosed space containing a source of ignition and from machinery and equipment which may constitute an ignition hazard. Such outlets shall be provided with high velocity vents designed and constructed in accordance with Schedule 3; and

**(e)** be so arranged as to prevent, the design pressure of any cargo tank being exceeded. For the purposes of this Schedule the system shall be designed on the basis of the maximum designed cargo loading rate of any tank or group of tanks multiplied by a factor of at least 1.25.

**5.** The venting arrangement of each cargo tank may be independent or combine with other cargo tanks and may be connected to the inert gas piping required by the Merchant Shipping (Fire Protection: Large Ships) Regulations 1997. Where the arrangements are combined with other cargo tanks, stop valves or other effective means of isolating each cargo tank shall be provided. Stop valves shall be provided with locking arrangements to permit control of their operation. Any cargo tank isolation arrangement provided in accordance with this paragraph shall not prevent the flow of vapour, air or inert gas caused by thermal variations within the tank.

**6.** The venting system shall be provided with devices to prevent the passage of flame into the cargo tanks. The design, construction, location and testing of these devices shall be in accordance with Schedule 3. The devices for cargo tanks in which the atmosphere is flammable shall be flame arrestors or high velocity vents. The devices for cargo tanks in which the atmosphere is rendered non-flammable by a fixed inert gas system provided in accordance with the Merchant Shipping (Fire Protection: Large Ships) Regulations 1997 may be flame screens.

**7.** The vents shall be connected to the top of each cargo tank and be self-draining to the cargo tanks. Other permanently installed drainage arrangements may be permitted where it is not possible to provide self-draining vent lines.

8. High level alarms or overflow control systems or other equivalent means together with cargo tank content gauges and filling procedures shall be provided to protect the tanks from excess pressure due to overfilling.

9. Isolation of the slop tanks containing oil or oil residue in combination carriers from other cargo tanks shall be by blank flanges, which shall remain in position at all times when cargoes other than oil cargoes are carried.

10. The master shall be provided with information regarding the maximum permissible loading rate for each cargo tank and, in the case of combined venting systems, for each group of cargo tanks.

***Schedule 2 Paragraphs 4(d) and 6***

**SCHEDULE 3**

**THE DESIGN, CONSTRUCTION, LOCATION AND TESTING OF DEVICES TO PREVENT THE PASSAGE OF FLAME INTO CARGO TANKS IN OIL TANKERS**

**Part 1 - Definitions**

In this Schedule -

"flame arrestor" means a device to prevent the passage of flame, complying with all relevant requirements of this Schedule. Its flame arresting mechanism is based on the principle of quenching;

"flame screen" means a device utilizing wire mesh to prevent the passage of unconfined flames, complying with all relevant requirements of this Schedule;

"flame speed" means the speed at which a flame propagates along a pipe or other system

"flash-back" means the transmission of a flame through a device;

"high velocity vent" means a device to prevent the passage of flame consisting of a mechanical valve which adjusts the opening available for flow in accordance with the pressure at the inlet of the valve in such a way that the efflux velocity cannot be less than 30 metres per second and complying with all relevant requirements of this Schedule;

"pressure/vacuum valve" means a device designed to maintain pressure and vacuum in a closed container with preset limits.

**Part 2 - Design**

2. (a) Devices, other than flame screens, shall be capable of performing one or more of the following functions -

***Flame arrestors and high velocity vents***

(i) permitting the gas to pass through passages without flash-back and without ignition of the gases on the protected side when the device is subjected to heating for the period of time specified in subparagraphs 5(c)(ii) and 6(c)(ii);

### ***High velocity vents***

(ii) maintaining an efflux velocity in excess of the flame speed for the gas irrespective of the geometric configuration of the device and without the ignition of gases on the protected side when the device is subjected to heating; and

### ***Flame arrestors and high velocity vents***

(iii) preventing an influx of flame when conditions of vacuum occur within the cargo tanks.

(b) Devices shall allow for efficient drainage of moisture without impairing their efficiency to prevent the passage of flame.

(c) The casting, element and gasket materials shall be capable of withstanding the highest pressure and temperature to which the device may be exposed under both normal and fire test conditions.

(d) Elements, gaskets and seals shall be of material resistant to corrosion by both sea water and the cargo.

(e) The casing or housing shall be capable of withstanding the hydrostatic pressure test required by subparagraph 4(i)

(f) In line devices shall be able to withstand without damage or permanent deformation the internal pressure resulting from detonation when tested in accordance with paragraph 7.

(g) Devices shall be designed to minimize the effect of fouling under normal operating conditions.

(h) Devices shall be capable of operating in freezing conditions and any device provided with heating arrangements so that its surface temperature exceeds 85°C shall be tested at the highest operating temperature.

(i) The clear area through flame arrestors shall be at least 1.5 times the cross-sectional area of the vent lines.

(j) High velocity vents shall be capable of opening in such a way that an efflux velocity of 30 metres per second is immediately initiated, maintained at all flow rates and be capable of closing in such a way that this minimum velocity is maintained until the valve is fully closed.

### **Part 3 - Construction**

The devices shall be of a construction adequate for the service for which they are intended, in particular -

**3.(a)** the casing or housing of devices shall be of material meeting at least the same standards of strength, heat resistance and corrosion resistance as the pipe to which it is attached;

**(b)** the devices shall allow ease of inspection and removal of internal elements for replacement, cleaning or repair;

**(c)** all flat joints of the housing shall be machined true and shall provide an adequate metal-to-metal contact;

(d) flame arrestor elements shall fit in the housing in such a way that flame cannot pass between the element and the housing;

(e) resilient seals may be installed only if their design is such that if the seals are damaged or burned, the device is still capable of effectively preventing the passage of flame;

(f) devices shall be so constructed as to direct the efflux vertically upwards;

(g) fastenings essential to the operation of the device such as screws shall be protected against loosening;

(h) means shall be provided to establish that if any valve is fitted it lifts easily without remaining in the open position;

(i) high velocity vents shall have a width of the contact area of the valve seat of at least 5 millimetres;

(j) devices shall not be capable of being by-passed or held open unless they are tested in the bypassed or open position in accordance with paragraphs 4, 5, 6 or 7, as appropriate;

(k) Flame screens shall be -

(i) such that they cannot be inserted improperly in the opening; and

(ii) securely fitted so that flames cannot circumvent the screen;

(l) each device shall be labelled or marked to indicate -

(i) the manufacturer's name or trademark, the style, type, model, or other manufacturer's designation for the device;

(ii) the size of the outlet for which the device is approved;

(iii) the approved location for installation including the maximum or minimum length of pipe, if any, between the device and atmosphere;

(iv) the direction of flow through the device; and

(v) the test laboratory and its report number

#### **Part 4 - Performance tests (General)**

**4.(a)** Devices shall be tested by an approved laboratory to show that they meet the requirements of this Schedule.

**(b)** Performance characteristics such as flow rates, operating sensitivity flow resistance and velocity shall be demonstrated.

**(c)** Flame screens shall be tested in accordance with subparagraph 5(b).

**(d)** Flame arrestors shall be tested in accordance with paragraph 5 or 7 as appropriate

(e) High velocity vents shall be tested in accordance with paragraph 6

(f) Only one prototype device shall be submitted for each test. The device tested shall have the same dimensions, with the most unfavourable tolerances allowed, as the design of the production model.

(g) Gasoline vapour (a non-leaded petroleum distillate consisting essentially of aliphatic hydrocarbon compounds with a boiling range of approximately 65°C to 75°C) or technical propane is to be used for the tests to establish that the devices are suitable for the explosive atmospheres that these requirements refer to.

(h) A corrosion test shall be carried out. A complete device including a section of the pipe to which it is fitted shall be exposed to a 20 per cent sodium chloride solution spray at a temperature of 25°C for a period of 240 hours, and allowed to dry for 48 hours. All movable parts shall thereafter operate properly and there shall be no corrosion deposits which cannot be washed off. Other equivalent tests may be accepted.

(i) A hydrostatic pressure test shall be carried out in which the casing or housing of the device shall withstand the following pressures -

Device	Pressure(kPa)
(i) End of Line	900
(ii) In line up to and including 200 mm pipe diameter	1,500
(iii) In line, above 200 mm. and up to and including 300mm pipe diameter	1,800
(i) In line, above 300mm. pipe diameter	to the satisfaction of the Marine Safety Agency

(j) The laboratory report of the test conducted shall contain the following information-

- (i) detailed and dimensioned drawings of the device;
- (ii) the types of tests conducted and the results obtained;
- (iii) specific advice on the approved attachments;
- (iv) the types of cargo for which the device is suitable;
- (v) drawings of the test rig;
- (vi) in the case of high velocity vents, the pressures at which the device opens and closes and the efflux velocity; and
- (vii) the markings on the device.

#### **Part 5 - Test procedures for flame screens and flame arrestors located at openings to the atmosphere**

**5.(a)** The test rig shall consist of an apparatus producing an explosive mixture, a small tank with a diaphragm, a flanged prototype of the device, a plastic foil bag and an ignition source in three

positions. A suitable test rig is shown at Figure 1. Other test rigs may be used, providing that the tests can be shown to be equivalent.

**(b)** A flash-back test shall be carried out as follows -

**(i)** the tank and the plastic foil bag shall be filled with the most easily ignitable propane/air mixture, the plastic foil bag enveloping the prototype device. The dimensions of the plastic foil bag are dependent on the dimensions of the device but for those normally used on tankers the foil bag shall have a circumference of 2 metres and a length of 2.5 metres and a wall thickness of 0.05 millimetres. Three ignition sources shall be installed in the bag, one close to the device, one as far away as possible therefrom, and the third at the midpoint between those two. These three sources shall be ignited in succession during the three tests;

**(ii)** if a flash-back occurs, the tank diaphragm will burst and this will be audible and visible to the operator by the emission of a flame. Flame, heat and pressure sensors may be installed as an alternative method of detecting a flash-back.

**(c)** An endurance burning test shall be carried out as follows, in addition to the flash-back test for flame arrestors at outlets where flows of explosive mixtures are foreseen -

**(i)** the test rig referred to in subparagraph 5(a) may be used, without the plastic foil bag. The flame arrestor shall be so installed that the mixture emission is vertical. In this position the mixture shall be ignited. Thermo-couples shall be installed on the flame arresting element;

**(ii)** flash-back shall not occur during this test. Endurance burning shall be achieved by using the most easily ignited gasoline vapour/air mixture with the aid of a pilot flame at the outlet. When the highest obtainable temperature of the exposed parts of the element is reached by varying the proportions of the flammable mixture and the flow rate the temperature shall be maintained for 10 minutes after which the flow shall be stopped and the condition of the device observed.

#### **Part 6 - Test procedures for high velocity vents**

**6.(a)** The test rig shall be capable of producing the required flow rate. Suitable test rigs are shown at Figures 2 and 3. Other test rigs may be used provided equivalent tests are achieved.

**(b)** A flow condition test shall be carried out with high velocity vents using compressed air or gas at agreed flow rates. The following characteristics shall be recorded

**(i)** the flow rate. Where air or a gas other than cargo vapours with which the vent is to be used is employed in the test, the flow rates achieved shall be corrected to reflect the vapour density of such cargoes;

**(ii)** the pressure before the vent opens. The pressure in the tank on which the device is located shall not rise at a rate greater than 10 kPa:

**(iii)** the pressure at which the vent opens;

**(iv)** the pressure at which the vent closes; and

**(v)** the efflux velocity measured at the outlet.

(c) The following fire safety tests shall be conducted using a mixture of gasoline vapour and air which produces the most easily ignitable mixture at the point of ignition. This mixture shall be ignited with the aid of a permanent pilot flame at the outlet –

(i) flash-back tests shall be carried out with the vent in the upright position and then inclined at 10 degrees to the vertical. For some vent designs further tests with greater inclinations of the vent may be required. In each of these tests the flow shall be reduced until the vent closes and the flame is extinguished and each test shall be carried out at least 50 times. The influx side of combined valves shall be tested in accordance with the requirements of subparagraph 5(b) with the vacuum valve held open;

(ii) an endurance burning test as prescribed in subparagraph 5(c) shall be carried out. In this test the main flame shall be extinguished and, with the pilot light on, small quantities of the most easily ignitable mixture shall be allowed to escape for a period of 10 minutes during which time flash-back shall not occur. For this test the soft seals or seats shall be removed.

#### **Part 7 - Test procedures for flame arrestors located in-line**

7.(a) A flame arrestor shall be installed at the end of a pipe of suitable length and of the same diameter as the flange of the flame arrestor. A plastic foil bag shall be secured to the exposed flange. The dimensions of the plastic foil bag shall be at least 4 metres circumference, 4 metres length and material wall thickness of 0.05 millimetres. The pipe shall be filled with the most easily ignitable mixture of propane and air, which shall then be ignited. The velocity of the flame near the flame arrestor shall be measured and shall have a value of that for the detonation velocity.

(b) A typical test rig is shown at Figure 4. Other test rigs may be used provided the tests are equivalent.

(c) Three detonation tests shall be conducted. No flash-back shall occur through the device and no part of the flame arrestor shall be damaged or show permanent deformation.

#### **Part 8 - Location and installation of devices**

8. (a) The devices installed shall preclude excess pressures in cargo tanks during loading or discharging. The following shall be taken into account in their selection

(i) cargo loading and discharge rates;

(ii) gas evolution;

(iii) pressure drop across the device taking into account the resistance coefficient;

(iv) pressure drop in the vent piping system;

(v) pressure at which the vent opens if a high velocity vent is selected; and

(vi) density of the saturated vapour/air mixture.

(b) Means shall be provided to enable personnel to reach devices situated more than 2 metres above deck to facilitate maintenance, repair and inspection.

(c) Devices shall be located at the outlets to atmosphere unless tested and approved for in-line installation. Devices for in-line installation shall not be fitted at the outlets to atmosphere unless they have been tested and approved for that position.

(d) Flame screens shall be protected against mechanical damage.

(e) Cowls, weatherhoods, nozzles, deflectors, tee-pieces, bends or orifice plates shall not be installed after flame arrestors unless the devices are tested and approved in association with these attachments. The distance between flame arrestors and the open ends of the pipes in which they are fitted shall be such that neither stationary flames nor heating leading to a flash-back can occur.

#### **Part 9 - Manufacturer's instruction manual**

(a) Devices shall have an instruction manual supplied by the manufacturer. This manual shall be kept on board the tanker and shall include the following information-

(i) installation instructions;

(ii) operating instructions;

(iii) maintenance requirements including the frequency and method of cleaning; and

(iv) a copy of the laboratory report.

**Regulation 35(2)**

### **SCHEDULE 4**

#### **STORAGE AND DISTRIBUTION OF OIL AND GASEOUS FUEL**

##### **Part 1 - Fuel**

1. In every ship in which oil or gaseous fuel is used in engines or boilers for the propulsion or safety of the ship, the arrangements for the storage, distribution and utilization of the fuel shall be such that the effective use of the engines can be maintained under all conditions likely to be met by the ship in service.

2. In every ship in which oil or gaseous fuel is used, the arrangements for the storage, distribution and utilization of the fuel shall be such that, having regard to the hazard of fire and explosion which the use of such fuel may entail, the safety of the ship and of persons on board is preserved.

3. Every oil fuel installation which serves a boiler supplying steam for the propulsion of the ship shall include not less than two oil fuel units.

##### ***Additional requirements for ships constructed on or after 1st September 1984***

4. In every ship in which oil or gaseous fuel is used, the arrangements for storage, distribution and utilization of fuel shall comply at least with the following provisions -

(a) oil fuel systems containing heated fuel oil at a pressure exceeding 180 kPa shall be in illuminated locations so that defects and leakage can be readily observed.

Where it is impracticable to meet the requirements of this subparagraph the Certifying Authority may permit other arrangements;

**(b)** oil fuel tanks shall be part of the ships structure and shall be located outside machinery spaces of Category A, When oil fuel tanks, except double bottom tanks, are necessarily located adjacent to or within machinery spaces of Category A at least one of their vertical sides shall be contiguous to the machinery space boundaries and, if practicable, they shall have a boundary common with the double bottom tanks. The area of the tank boundary common with the machinery space shall be kept to a minimum. Any oil fuel tank located within the boundaries of machinery spaces of Category A shall not contain fuel having a flashpoint of less than 60°C. Where it is impracticable to meet the requirements of this subparagraph, the Certifying Authority may permit other arrangements;

**(c)** every oil fuel tank shall, where necessary, be provided with save-alls or gutters which will catch any oil which may leak from the tank;

**(d)** oil fuel tanks shall not be situated directly above boilers or other heated surfaces;

**(e)** oil fuel shall not be carried in forepeak tanks;

**(f)** means shall be provided for the removal of water from fuel oil. Such means shall include the fitting of water drain valves to daily service tanks, settling tanks and where practicable, to other oil fuel tanks. Where the removal of water by drain valves is impracticable water separators shall be fitted in the supply lines to propulsion machinery;

**(g)** save-alls or gutters and screens shall be provided to prevent oil fuel that may leak under pressure from any pump, filter or heater from coming into contact with boilers or other heated surfaces;

**(h)** every pipe connected to any oil fuel storage, settling, or daily service tank, not being a double bottom tank, which if damaged would otherwise permit discharge of the contents so as to cause a fire hazard shall be fitted with a valve or cock which shall be secured to the tank to which it is connected and be capable of being closed from a readily accessible position outside the space in which the tank is situated provided that in the case of any inlet pipe to such a tank, a non-return valve similarly secured to the tank may be substituted. In the case of an oil fuel deep tank traversed by any shaft or pipe tunnel, in addition to the valve or cock secured to the tank, a valve or valves may be fitted on the pipe line or lines outside the tunnel or tunnels to enable control to be exercised in the event of fire;

**(i)** provision shall be made which will prevent overpressure in any oil fuel tank oil fuel filling pipe or any part of the oil fuel system. Air and overflow pipes and relief valves shall discharge to a position where there will be no risk of fire or explosion from the emergence of oil or oil vapour; and

**(j)** every oil fuel pipe shall be made of steel or other suitable material except that flexible pipes may be permitted in positions where the Certifying Authority is satisfied that they are necessary; such flexible pipes and their attachments shall be constructed to the satisfaction of the Certifying Authority.

**5.** Safe and efficient means of ascertaining the amount of oil fuel contained in any oil fuel tank shall be provided. Sounding pipes shall not terminate in any space where the risk of ignition of spillage therefrom could arise. In particular, sounding pipes shall not terminate in passenger

spaces or crew spaces. Other means of ascertaining the amount of oil fuel may be permitted provided that the failure of such means or overfilling of the tanks will not permit release of oil fuel.

### ***Requirements for ships constructed on or after 1st February 1992***

**6.** Sounding pipes shall not terminate in machinery spaces. However where the Certifying Authority considers that impracticable it may permit the termination of sounding pipes in machinery spaces on condition that

- (a) an oil level gauge is provided meeting the requirements of subparagraph 6(d);
- (b) the sounding pipes terminate in locations remote from ignition hazards unless precautions are taken, such as the fitting of effective screens to prevent the oil fuel in the case of spillage through the terminations of the sounding pipes from coming into contact with a source of ignition;
- (c) the terminations of sounding pipes are fitted with self-closing blanking devices and with a small diameter self-closing control cock located below the blanking device for the purpose of ascertaining before the blanking device is opened that oil fuel is not present. Provision shall be made so as to ensure that any spillage of oil through the control cock involves no ignition hazard; and
- (d) oil level gauges may be used in place of sounding pipes. Such gauges shall be such that their failure, or the over-filling of the tank, shall not permit release of fuel into the machinery spaces. The use of cylindrical gauge glasses is prohibited. The Certifying Authority may permit this use of oil-level gauges with flat glasses and self-closing valves between the gauges and fuel tank. Oil-level gauges shall be maintained in proper condition to ensure their continued accurate functioning in service.

## **Part 2 - Lubricating and other oil systems**

### ***Requirements for ships constructed on or after 1st September 1984***

**7.** The arrangements for the storage, distribution and utilization of lubricating oil in machinery spaces of Category A shall comply with the requirements of subparagraphs 4(a) 4(d), 4(g), 4(h), 4(i), 4(j) and paragraphs 5 and 6 as applicable as they apply to oil fuel installations except that tank gauges of the flat glass type, provided with self-closing valves at each tank connection and sight flow glasses having an acceptable degree of fire resistance may be permitted. Alternative arrangements may be permitted in machinery spaces other than machinery spaces of Category A where the Certifying Authority is satisfied that the safety of the ship is not impaired.

**8.** The arrangements for the storage, distribution and utilization of flammable oils, other than fuel and lubricating oil, used in power transmission control and activating systems and heating systems shall be such as to ensure the safety of the ship and persons on board. In enclosed spaces containing a source of ignition the arrangements shall comply with subparagraphs 4(d), 4(g), 4(i), 4(j) and paragraphs 5 and 6 as they apply to oil fuel installations except that tank gauges of the flat glass type provided with selfclosing valves at each tank connection may be permitted.

## **Part 3 - Arrangements for oil fuel systems**

**9.** Ships constructed before 1st July 1998 shall comply with the requirements of paragraphs 10, 11 and 12 not later than 1st July 2003, except that a suitable enclosure on engines having an output of 375 kW or less having fuel injection pumps serving more than one injector may be used as an alternative to, the jacketed piping system in paragraph 10.

**10.** All external high pressure fuel delivery lines between the high pressure fuel pumps and fuel injectors shall be protected with a jacketed piping system capable of containing fuel from a high pressure line failure. A jacketed pipe incorporates an outer pipe into which the high pressure fuel pipe is placed forming a permanent assembly. The jacketed piping system shall include a means for collection of leakages and arrangements shall be provided for an alarm to be given of a fuel line failure.

**11.** All surfaces with temperatures above 220 degrees which may be impinged as a result of a fuel system failure shall be properly insulated.

**12.** Oil fuel lines shall be screened or otherwise suitably protected to avoid as far as practicable oil spray or oil leakages onto hot surfaces, into machinery air intakes, or other sources of ignition. The number of joints in such piping systems shall be kept to a minimum.

### ***Regulation 37***

## **SCHEDULE 5**

### **REMOTE CONTROL OF PROPULSION MACHINERY FROM THE NAVIGATING BRIDGE**

**1.** In every ship provided with remote control of the propulsion machinery from the navigating bridge the following provisions shall apply

**(a)** the speed, direction of thrust and, if variable, the pitch of the-propeller shall be fully controllable from the navigating bridge under any sailing condition including manoeuvring;

**(b)** the remote control from the navigating bridge shall be performed by a single control device for each independent propeller; each such device shall, where necessary, be provided with means of preventing overload of the propulsion machinery; provided that multiple propeller installations may be controlled by a single control device;

**(c)** propulsion machinery movements selected at the navigating bridge shall be indicated in the main machinery control room or at the manoeuvring platform as appropriate;

**(d)** the main propulsion machinery shall be provided with an emergency stopping device, located on the navigating bridge, which shall be independent of the controls otherwise required;

**(e)** remote control of the propulsion machinery shall be possible from only one location at a time. Inter-connected control units may be permitted at such locations. There shall be provided at each location an indicator showing which location is in control of the propulsion machinery. Transfer of control between the navigating bridge and the machinery spaces shall only be possible from the machinery space or the main machinery control room. The control system shall be arranged so that the propeller thrust does not alter significantly when control is transferred from one station to another;

(f) means shall be provided to control the propulsion machinery locally in the event of failure of the remote control system;

(g) the design of the propulsion machinery remote control system shall be such that in the event of its failure an alarm will be given and the preset speed and direction of thrust maintained until local control is in operation; the Certifying Authority may waive this requirement where other essential features of the system design render compliance impracticable, subject to such alternative provisions as it may require;

(h) indication shall be given on the navigating bridge of -

(i) propeller speed and direction of rotation in the case of fixed pitch propellers; and

(ii) propeller speed and pitch position in the case of controllable pitch propellers;

(i) the number of automatic and consecutive attempts which fail to start any internal combustion propulsion engine shall be limited so as to maintain sufficient air pressure for further attempts under local control; and

(j) an alarm shall be provided on the navigating bridge and in the machinery space to indicate low starting air pressure at a level which still permits main propulsion machinery starting operations.

2. Every ship provided with means of remote or automatic control of the main propulsion machinery and its associated machinery, including the sources of main electric supply, enabling that machinery to be operated and supervised from a control room shall be as safe as if the machinery were under direct supervision.

3. Any automatic starting, operating or control system shall be so designed that the failure of any part of such systems shall not prevent their operation manually.

### ***Regulation 38***

## **SCHEDULE 6**

### **STEERING GEARS**

#### **Part 1 - General**

1.(a) Every ship shall be provided with an efficient main steering gear and, subject to subparagraph 1(e) an efficient auxiliary steering gear; Provided that if duplicate steering gear power units and their connections are fitted to the satisfaction of the Certifying Authority and each power unit complies with the requirements of subparagraph 1(d) no auxiliary steering gear shall be required.

(b) The main steering gear and the auxiliary steering gear shall be arranged so that the failure of one of them will not render the other one inoperative.

(c) The main steering gear and rudder stock shall -

(i) be of adequate strength and sufficient to steer the ship at maximum ahead service speed;

(ii) be capable of putting the rudder over from 35 degrees on one side to 35 degrees on the other side with the ship running ahead at maximum service speed and under the same conditions, from 35 degrees on either side to 30 degrees on the other side in not more than 28 seconds; and

(iii) be designed so that they will not be damaged at maximum astern speed.

(d) The auxiliary steering gear shall

(i) be of adequate strength and capable of being brought speedily into action, in an emergency; and

(ii) be of sufficient power to enable the ship to be steered at navigable speed, and in any such ship in which a rudder stock of over 355.6 millimetres in diameter in way of the tiller is required to comply with the requirements of subparagraphs 1(c)(i) and 1(c)(iii), the auxiliary steering gear shall be operated by power.

(e) Notwithstanding subparagraph 1(a) an auxiliary steering gear need not be fitted if

(i) two or more identical steering gear power units are provided which when operating simultaneously are capable of operating the rudder in accordance with the requirements of subparagraph 1(c)(ii); and

(ii) the main steering gear is so arranged that after a single failure in its piping system or in one of the power units the defect can be isolated so that steering capability can be maintained or speedily regained. A steering gear with a proven record of reliability that does not comply with this subparagraph may be permitted by the Certifying Authority on ships the keel of which was laid before 1st September 1986.

(f) In every ship which is fitted with a power operated steering gear the position of the rudder shall be indicated at the principal steering station.

(g) Simple operating instructions with a block diagram showing the change over procedures for remote steering gear control systems and steering gear power units shall, where applicable, be permanently displayed on the navigating bridge and in the steering gear compartment.

***Additional Requirements for ships constructed on or after 1st September 1984***

(h) (i) The steering gear components and the rudder stock shall be of sound and reliable construction. In particular single essential components such as tillers and hunting gear shall be designed and constructed to withstand, with an adequate factor of safety, the maximum working stresses to which they may be subjected. Any bearings for such essential components shall be of a suitable type which shall be permanently lubricated or provided with lubrication fittings.

(ii) The design pressure for steering gear components and piping subject to internal hydraulic pressure shall be at least 1.25 times the maximum working pressure anticipated when the steering gear is operating taking into account any pressure which may exist in the low pressure side of the system. Fatigue criteria, taking into account pulsating pressure due to dynamic loads, shall be taken into account for the design of piping and components if the Certifying Authority considers it appropriate.

**(iii)** Relief valves shall be fitted to any part of the hydraulic system which can be isolated and in which pressure can be generated from a power unit or from external forces. The pressure at which relief valves operate shall not exceed the design pressure. The valves shall be of adequate size so as to avoid an undue rise in pressure above the design pressure.

**(i)** The main steering gear and rudder stock shall be operated by power if necessary to meet the requirements of subparagraph 1(c)(ii) and in any case when the diameter of the rudder stock in way of the tiller is required to be greater than 120 millimetres excluding additional strengthening for navigation in ice.

**(j)** The auxiliary steering gear shall –

**(i)** be capable of putting the rudder over from 15 degrees on one side to 15 degrees on the other side in not more than 60 seconds with the ship at its deepest seagoing draught and running ahead at one half of the maximum ahead service speed or 7 knots, whichever is the greater; and

**(ii)** operated by power if necessary to meet the requirements of subparagraph 1(j)(i) and in any case when the diameter of the rudder stock in way of the tiller is required to be greater than 230 millimetres excluding additional strengthening for navigation in ice.

**(k)** The angular position of the rudder shall be indicated in the steering gear compartment and, if the main steering gear is power operated, at the steering station on the navigating bridge. The rudder angle indicator system shall be independent of any steering gear control system.

**(l)** Steering gears other than of the hydraulic type shall achieve equivalent standards to those required by this Schedule.

**(m)** Main and auxiliary steering gear power units shall –

**(i)** be arranged to re-start automatically when power is restored after a power failure;

**(ii)** be capable of being brought into operation from a position on the navigating bridge; and

**(iii)** be provided with an audible and visual alarm on the navigating bridge that will operate in the event of a power failure to any steering gear power unit.

**(n)** **(i)** Main steering gear control shall be provided on the navigating bridge and in the steering gear compartment. Two independent control systems operable from the navigating bridge shall be provided for a steering gear arranged in accordance with subparagraph 1(e). A single hydraulic telemotor control system may be permitted by the Certifying Authority on any ship other than a tanker, chemical tanker or gas carrier of 10,000 tons or over. The steering wheel or steering lever need not be duplicated.

**(ii)** Auxiliary steering gear control shall be provided in the steering gear compartment and, if the auxiliary steering gear is power operated, from the navigating bridge. Any auxiliary steering gear control system provided on the navigating bridge shall be independent of the control system for the main steering gear.

**(o)** Every main and auxiliary steering gear control system shall

- (i) if electric, be served by its own separate circuit supplied from a steering gear power circuit from a point within the steering gear compartment or directly from switchboard busbars supplying that steering gear power circuit at a point on the switchboard adjacent to the supply to the steering gear power circuit;
  - (ii) be provided in the steering gear compartment with means for disconnecting the control system from the steering gear it serves;
  - (iii) be capable of being brought into operation from a position on the navigating bridge;
  - (iv) be provided with an audible and visual alarm on the navigating bridge that will operate in the event of a failure of the electric power supply to the control system; and
  - (v) be provided only with short circuit protection for the electric supply circuits.
- (p) Electric power circuits and the steering gear control system with their associated components, cables and pipes shall be separated as far as is practicable throughout their length.
- (q) A means of communication to both order and respond to steering commands shall be provided between the navigating bridge and the steering gear compartment.
- (r) Hydraulic power operated steering gear shall be provided with
- (i) arrangements to maintain the cleanliness of the hydraulic fluid taking into consideration the type and design of the hydraulic system;
  - (ii) a low level alarm for each hydraulic fluid reservoir arranged to give audible and visual alarms on the navigating bridge and in the machinery space in the event of leakage of the hydraulic fluid; and
  - (iii) a fixed storage tank having sufficient capacity to recharge at least one power actuating system, including the reservoir, where the main steering gear is required to be power operated. The storage tank shall be provided with a contents gauge and shall be permanently connected by piping in such a manner that the hydraulic systems can be readily recharged from a position within the steering gear compartment.
- (s) The steering gear compartment shall be readily accessible and, as far as is practicable, separated from the machinery spaces. Handrails and gratings or other non-slip surfaces shall be provided to ensure suitable working conditions at the steering- gear machinery and controls in the event of hydraulic fluid leakage.
- (t) An alternative power supply shall be provided in every ship where the diameter of the rudder stock is required to be 230 millimetres or more excluding any strengthening for navigating in ice. The alternative power supply shall be provided automatically within 45 seconds either from the emergency source of electric power or from an independent source of power located in the steering gear compartment. The independent source of power shall be used for this purpose only. The alternative power supply shall be at least sufficient to provide power for the steering gear to comply with the performance requirements of subparagraph 1(j)(i) and for its associated control system and rudder angle indicator. The alternative power supply shall have a capacity sufficient for at least 30 minutes of continuous operation in every ship of 10,000 tons or over and at least 10 minutes of continuous operation in any other ship.

**(u)** In every tanker of 10,000 tons or over and every other ship of 70,000 tons or over the main steering gear shall have two or more identical power units complying with the requirements of subparagraph 1(e).

**(v)** The main steering gear in every tanker of 10,000 tons or over shall, subject to the requirements of subparagraph 1(w), be so arranged that in the event of loss of steering capability due to a single failure in any part of one of the power actuating systems, other than seizure of a rudder actuator, steering capability shall be regained in not more than 45 seconds after the loss of one power actuating system. The main steering gear shall comprise either

**(i)** two independent and separate power actuating systems each capable of meeting the requirements of subparagraph 1(c)(ii); or

**(ii)** at least two identical power actuating systems which shall be capable of meeting the requirements of subparagraph 1(c)(ii) when acting simultaneously in normal operation. Interconnection of the hydraulic power actuating systems shall be provided, if necessary for compliance with this requirement. The loss of hydraulic fluid from one system shall be capable of being detected and the defective system automatically isolated so that the other actuating system or systems remain fully operational.

**(w)** In any tanker of 10,000 tons or over but of less than 100,000 tonnes deadweight the main steering gear may be constructed in such a way that the single failure criterion required by subparagraph 1(v) is not applied to the rudder actuator or actuators provided that

**(i)** steering capability shall be regained within 45 seconds of a single failure of any part of the piping system or in one of the power units; and

**(ii)** the design, construction and testing of the rudder actuator is in accordance with the requirements of Schedule 7 if only one actuator is provided.

## **Part 2 - Electric and electro-hydraulic steering gear**

**(a)** Every ship which is fitted with electric or electro-hydraulic steering gear shall be provided with indicators which will show when the power units of such steering gear are running. These indicators shall be situated in the machinery control room or in such other position or positions as the Certifying Authority may approve, and on the navigating bridge.

**(b)** In every ship of 5,000 tons or over and in every ship constructed on or after 1st September 1984, steering gear shall, subject to subparagraph 2(c),

**(i)** be served by at least two exclusive circuits fed from the main switchboard one of which may pass through the emergency switchboard; each circuit shall have adequate capacity for supplying all the motors which are normally connected to it and which operate simultaneously, and if transfer arrangements are provided in the steering gear compartment to permit either circuit to supply any motor or combination of motors, the capacity of each circuit shall be adequate for the most severe load condition; the circuits shall be separated as widely as is practicable throughout their length; an auxiliary electric or electro-hydraulic steering gear may be connected to one of the circuits supplying the main steering gear; and

**(ii)** be provided with short circuit protection and an overload alarm for the protection of the circuits and motors. In the case of ships constructed on or after 1st September 1984 any protection provided against excess current shall be capable of conducting at least

twice the full load current of the motor or motors taking into consideration the motor Starting currents; when a three phase supply is used an alarm shall be provided that will indicate the failure of any one of the supply phases; the alarms required by this subparagraph shall be both audible and visual and located in a conspicuous position in the main machinery space or in the control room from which the main machinery is normally controlled;

(c) In every ship of under 5000 tons in which the electrical power is the sole source of power for both main and auxiliary steering gear, the arrangement shall comply with the requirements of the preceding paragraph, except that if the auxiliary steering gear is powered by a motor primarily intended for other services, suitable overload protection shall be fitted. Only short circuit protection need be provided for the motor and power circuits of any electrically or electro-hydraulically operated main steering gear fitted in any ship of less than 5000 tons.

(d) The main steering gear in any ship of less than 1600 tons may be fed by one circuit from the main switchboard if the auxiliary steering gear is not electrically powered or is powered by an electric motor primarily intended for other purposes. The Certifying Authority may permit arrangements for such motors other than those required by subparagraphs 1(m)(i), 1(m)(ii), and 2(b)(ii) if it considers it safe so to do.

### **Part 3 - Steering gear in tankers**

**3.(a)** In addition to requirements otherwise imposed by Parts 1 and 2 every tanker, the keel of which was laid or which was at a similar stage of construction before 1st September 1984, shall comply with the requirements of subparagraphs 3(b) to 3(d).

#### ***Tankers of 10,000 tons or over***

(b) In every tanker (including chemical tankers and gas carriers) of 10,000 tons or over -

(i) two steering gear control systems shall be provided, each of which shall be capable of being operated separately from the navigating bridge. Duplication of the steering wheel or lever is not required;

(ii) in the event of failure of the steering gear control system in operation, the other system shall be capable of being brought into immediate operation from a position on the navigating bridge;

(iii) each steering gear control system, if electric, shall be served by its own separate circuit supplied from a steering gear power circuit from a point within the steering gear compartment or directly from switchboard busbars supplying that steering gear power circuit at a point on the switchboard adjacent to the supply to the steering gear power circuit;

(iv) in the event of failure of electrical power supply to a steering gear control system, an alarm shall be given on the navigating bridge which shall be audible and visual and situated where it can be readily observed;

(v) means for control of the main steering gear shall be provided in the steering gear compartment;

(vi) means shall be provided in the steering gear compartment to disconnect the steering gear control system from the steering gear it serves;

(vii) means of communication shall be provided between the navigating bridge and the steering gear compartment;

(viii) the rudder angle indication system on the navigating bridge shall be independent of the steering gear control system;

(ix) the angular position of the rudder shall be recognisable in the steering gear compartment;

(x) a low level alarm shall be provided for each hydraulic fluid reservoir to give the earliest practicable indication of hydraulic fluid leakage. Audible and visual alarms shall be given on the navigating bridge and in the machinery space where they can be readily observed;

(xi) a fluid storage tank shall be provided having sufficient capacity to recharge at least one power actuating system including the reservoir. The storage tank shall be permanently connected by piping in such a manner that the hydraulic systems can be readily recharged from a position within the steering gear compartment and shall be provided with a contents gauge; and

(xii) the steering gear compartment shall be provided with suitable arrangements to ensure working access to the steering gear machinery and controls. These arrangements shall include handrails and gratings or other non-slip surfaces to ensure suitable working conditions in the event of hydraulic fluid leakage.

#### ***Tankers of 40,000 tons or over***

(c) In every tanker (including chemical carriers and gas carriers) of 40,000 tons or over the steering gear shall be so arranged that, in the event of a single failure of the piping or of one of the power units, steering capability can be speedily regained. This shall be achieved by –

(i) an independent means of restraining the rudder; or

(ii) fast acting valves, which may be manually operated, to isolate the actuator or actuators from the external hydraulic piping together with a means of directly refilling the actuators by a fixed independent power-operated pump and piping system; or

(iii) an arrangement such that, where hydraulic power systems are interconnected, loss of hydraulic fluid from one system shall be detected and the defective system isolated either automatically or from the navigating bridge so that the other system remains fully operational.

#### ***Tankers constructed on or after 1st June 1979***

(d) The provisions of subparagraphs 3(e), 3(f), 3(g) and 3(h) shall apply to every tanker (except chemical tankers and gas carriers) of 10,000 tons or over -

(i) for which the building contract was placed after 1st June 1979; or

(ii) in the absence of a building contract, the keel of which was laid or which was at a similar stage of construction after 1st January 1980; or

(iii) the delivery of which was after 1st June 1982; or

(iv) which has undergone an alteration or modification of a major character -

(aa) for which the contract was placed after 1st June 1979; or

(bb) in the absence of a contract, the construction work of which was begun after 1st January 1980; or

(cc) which was completed after 1st June 1982.

(e) The main steering gear shall comprise two or more identical power units and it shall be capable of operating the rudder as required by subparagraph 1(c)(ii) while operating with one or more power units. As far as is reasonable and practicable, the main steering gear shall be so arranged that a single failure in its piping or in one of the power units will not impair the integrity of the remaining part of the steering gear. All mechanical components which are part of the steering gear and the mechanical connection with any steering gear control system, if any, shall be of sound construction.

(f) The main steering gear power units shall be arranged to start automatically when power is restored after a power failure.

(g) In the event of failure of any of the steering gear power units, means shall be provided to ensure that an alarm shall be given on the navigating bridge. Every steering gear power unit shall be capable of being brought into operation either automatically or manually from a position on the navigating bridge.

(h) An alternative power supply, at least sufficient to supply a steering gear power unit so as to enable it to move the rudder as specified below, and also to supply its associated steering gear control system and the rudder angle indicator shall be provided automatically, within 45 seconds either from the emergency source of electrical power, or from another independent source of power located in the steering gear compartment. This independent source of power shall be used only for this purpose and shall have a capacity sufficient for half an hour of continuous operation. The steering gear power unit, when being supplied by the alternative power supply, shall at least be capable of putting the rudder over from 15 degrees on one side to 15 degrees on the other side in not more than 60 seconds with the ship at its deepest sea-going draught while running at one half of its maximum service speed ahead or 7 knots whichever is the greater.

***Schedule 6 Paragraph 1(w)(ii)***

## **SCHEDULE 7**

### **CONSTRUCTION OF RUDDER ACTUATORS FOR CERTAIN TANKERS**

#### ***Materials of Construction***

1. Rudder actuator components subject to internal hydraulic pressure or for transmitting mechanical forces to the rudder stock shall be constructed of ductile materials which have been tested to establish their mechanical properties. Such materials shall not have an elongation less than 12 per cent on a gauge length of five times the diameter of the test piece or an ultimate tensile strength greater than 650 Newtons per square millimetre.

**Design and Stress Analysis**

2. Subject to paragraph 4, detailed calculations, including a stress analysis of the pressure retaining parts of the actuator, shall be provided so that the Certifying Authority can establish that the design of the rudder actuator is suitable for its intended purpose. A fatigue analysis and a fracture mechanics analysis shall be undertaken if the Certifying Authority considers it necessary due to the complexity of the design or the method of manufacture. Such analyses shall take all foreseen dynamic loads into account and shall be supplemented by experimental stress analysis if the Certifying Authority considers it necessary.

**Allowable Stresses**

3. For the purpose of determining the scantlings of rudder actuator components subject to internal hydraulic pressure the allowable stresses shall not exceed -

$$\begin{aligned} \sigma_m &\leq f \\ \sigma_t &\leq 1.5 f \\ \sigma_b &\leq 1.5 f \\ \sigma_t + \sigma_b &\leq 1.5 f \\ \sigma_m + \sigma_b &\leq 1.5 f \end{aligned}$$

where -

$\sigma_m$  is the equivalent primary general membrane stress,  
 $\sigma_t$  is the equivalent primary local membrane stress,  
 $\sigma_b$  is the equivalent primary bending stress,

$$f = \sigma \frac{B}{A} \text{ or } \sigma \frac{Y}{B} \quad \text{whichever is smaller, where -}$$

$\sigma_B$  is the specified minimum tensile strength of material at ambient temperature, and

$\sigma_Y$  is the specified minimum yield stress or 0.2% proof stress of material at ambient temperature

A and B being in accordance with the following table –

Material	Forged Steel	Cast Steel	Nodular Cast Iron
A	4	4.6	5.8
B	2	2.3	3.5

**Burst Test**

4. Rudder actuator components subject to internal hydraulic pressure that have not been subject to a detailed stress analysis in accordance with paragraph 2 may be accepted by the

Certifying Authority on the basis of a satisfactory burst test. The minimum bursting pressure shall be determined by the formula -

$$P_b = P.A. \frac{\sigma_{Ba}}{\sigma_B}$$

where -

$P_b$  is the minimum bursting pressure;

P is the design pressure as specified in subparagraph 1(h)(ii) of Schedule 6;

A is the appropriate number taken from the table in paragraph 3;

$\sigma_{Ba}$  is actual tensile strength; and

$\sigma_B$  is the specified minimum tensile strength of the material at ambient temperature.

### **Construction**

**5.(a)** Local concentrations of stress shall be minimised.

**(b)** All welded joints within the pressure boundary of a rudder actuator or connecting parts transmitting mechanical loads shall be the full penetration type or be of equivalent strength. The weld details and welding procedure shall be to the satisfaction of the Certifying Authority.

**(c)** Oil seals between stationary components that form any part of the external pressure boundary shall be of the metal to metal type or equivalent.

**(d)** At least two oil seals shall be provided between components having relative movement to each other that form any part of the external pressure boundary so that the failure of one will not render the actuator inoperative. The Certifying Authority may permit other arrangements providing equivalent protection against leakage.

**(e)** Isolating valves, directly mounted on the actuator, shall be provided at every pipe connection to the actuator.

**(f)** The relief valves for the rudder actuator required by subparagraph 1(h)(iii) shall have a discharge capacity of at least the total capacity of the pumps which provide power for the actuator increased by 10 per cent. Under such conditions the rise in pressure above the set pressure shall not exceed 10 per cent, due consideration being given to the effect of foreseen ambient conditions on the viscosity of the oil.

### **Testing**

**6.(a)** The rudder actuator shall be completely examined for surface and volumetric flaws by non-destructive testing techniques and procedures acceptable to the Certifying Authority. Fracture mechanics analysis may be accepted for determining the maximum allowable flaw size.

**(b)** Pressure parts of the actuator shall be tested hydrostatically to 1.5 times the design pressure. The rudder actuator shall be subjected to a further hydrostatic test and a running trial when it is installed in the ship.

**SCHEDULE 8**

**PROTECTION AGAINST NOISE**

1. Noise levels in machinery spaces shall not exceed 110 dB(A) provided that the Secretary of State, may, under such conditions as he may specify, permit higher noise levels having regard to the size of the ship and the type of machinery installed.
2. Any machinery space in which the noise level exceeds 90 dB(A) and which is required to be manned shall be provided with a designated refuge from noise where the noise level does not exceed 75dB(A).
3. Every entrance to a machinery space in which the noise level exceeds 85 dB(A) shall be provided with a warning notice comprising a symbol complying with British Standards Institution specification number BS 5378:1980 and a supplementary sign stating "High Noise Levels. Use Ear Protectors". Sufficient ear protectors shall be provided for use in such spaces."
4. Noise levels in machinery spaces shall be measured when the largest number of machines that operate simultaneously in service are at their normal service loads. Measurements taken during sea trials at normal ahead service speed of the ship will be accepted.
5. The equipment and procedures for measuring and recording noise levels in machinery spaces shall be generally in accordance with the provisions of the publication entitled "The Code of Practice for Noise Levels in Ships" published by Her Majesty's Stationery Office or to any other appropriate standard or Code of Practice (e.g. IMO Res. A 468 (XII)) for this purpose.

**SCHEDULE 9**

**PERIODICALLY UNATTENDED MACHINERY SPACES**

***General***

1. Every ship shall be provided with effective means for control of, and arrangements for monitoring the operation of, the machinery used or essential for propulsion, so that the safety of the ship in all sailing conditions, including manoeuvring is not less than that of a ship with continuously manned machinery spaces.

***Operation and documentation***

2. In every ship, the Certifying Authority shall ensure that the equipment provided for operating the ship with the machinery spaces containing machinery used or essential for propulsion periodically unattended, is functioning in a reliable manner before the ship is permitted to operate with those machinery spaces unattended. The Certifying Authority shall ensure that satisfactory arrangements are made for periodic inspections and routine tests on such equipment to ensure continuous and reliable operation and shall issue documentary

evidence indicating that it is satisfied that the ship and its equipment is suitable for operation in the said conditions.

### ***Alarm systems***

3. Every ship shall be provided with an alarm system which shall indicate any fault in the unattended machinery or unattended machinery spaces requiring attention. The alarm system shall -

(a) indicate each separate alarm condition visually at the machinery alarm and control centre and provide an audible alarm at that centre and in the machinery spaces;

(b) be connected to the engineers' public rooms and to each of the duty engineers' cabins so that at least one of the duty engineers' cabin is connected to the alarm system at any time. The Certifying Authority may permit equivalent alternative arrangements;

(c) be connected to an audible and visual alarm on the navigating bridge which shall be activated for any situation which requires the action of, or should be brought to the attention of, the officer of the watch;

(d) as far as practicable be designed to indicate an alarm condition should a failure of the alarm and monitoring system occur;

(e) activate an alarm that is clearly audible in the engineers' accommodation if an alarm condition has not received attention at the machinery alarm and control centre within a reasonable time;

(f) in the event of a loss of the normal power supply, be supplied automatically from a stand-by power supply; the failure of the normal power supply shall be indicated on the alarm system; and

(g) be able to indicate multiple faults simultaneously; the acceptance of any fault on the alarm system shall not inhibit other alarms; acceptance of the alarm at the machinery alarm and control centre shall be indicated at the other positions where the alarm condition is shown; alarms shall be maintained until they are accepted and the visual indication of individual alarms shall remain until the fault has been corrected when the alarm system shall automatically be reset to its normal operating condition.

### ***Safety system***

4. A safety system shall be provided so that malfunction in the machinery which presents an immediate danger shall initiate the automatic shut-down of the defective machinery and give an alarm. The main propulsion machinery shall not be automatically shut down except when continued operation would cause serious damage, complete breakdown or an explosion. Arrangements for overriding the automatic shut-down of the main propulsion machinery may be permitted, provided that the operating arrangements preclude inadvertent operation. Visual indication shall be provided to show whether or not the override has been activated. A suitable notice, warning of the possible effect of overriding shall be displayed at the override position.

### ***Communication***

5. Every ship shall be provided with a means of vocal communication between the propelling engine room, main machinery control room, or manoeuvring platform as appropriate, the navigating bridge and the engineers' accommodation.

### ***Control of propulsion machinery***

6. In every ship the speed of rotation, direction of thrust and, if applicable the pitch of the propeller shall be fully controllable from the navigating bridge and the following provisions shall apply -

(a) the remote control from the navigating bridge shall be performed by a single control device for each independent propeller with automatic performance of all associated services including where necessary means of preventing overload of the propulsion machinery;

(b) propulsion machinery movements selected at the navigating bridge shall be indicated at the machinery alarm and control centre; and

(c) means of controlling the propulsion machinery and other machinery essential for the propulsion of the ship locally in the event of failure of any part of the automatic or remote control systems shall be provided.

### ***Machinery, boilers and electrical installations***

7.(a) An automatic control system, and an alarm system shall be provided to the satisfaction of the Certifying Authority for all important functions including pressures, temperatures and fluid levels. The control system shall be such that through the necessary automatic arrangements the services needed for the operation of the main propulsion machinery and its auxiliaries are ensured.

(b) In every ship of 1600 tons or over, and, where practicable, in ships of less than 1600 tons, where the electrical power is normally supplied by one generator, there shall be provided suitable load shedding arrangements to ensure the integrity of supplies to services required for propulsion, steering and to ensure the safety of the ship. There shall be adequate provision, in the event of loss of the generator in operation, for automatically starting and connecting to the main switchboard a standby generator of sufficient capacity to sustain propulsion, steering and to ensure the safety of the ship, and automatic restarting of the essential auxiliaries including, where necessary, sequential operation.

(c) Where stand-by machinery is necessary to ensure continuity of services essential for propulsion, automatic changeover devices shall be provided. An alarm shall be given on automatic changeover.

### ***Fire safety***

8.(a) Every fuel oil and lubricating oil pressure pipe shall where necessary, be screened or otherwise suitably protected to prevent oil, in the event of a failure of that pipe, coming into contact with hot surfaces or entering machinery air intakes. High pressure fuel oil pipes of compression ignition engines shall, additionally, be provided with means of collecting, at a safe location, any such oil and indicating the fault on the alarm system.

(b) Every oil fuel tank that directly supplies the main propulsion machinery or its auxiliaries and which is arranged to be filled automatically or by remote control shall be provided with means to prevent overflow and spillage. Every such tank and settling tank fitted with oil fuel heating arrangements shall be provided with a high temperature alarm if the flashpoint of the oil fuel therein can be exceeded.

(c) The equipment (such as oil fuel purifiers) for preparing flammable liquids for use in boilers or machinery shall have arrangements to prevent overflow and spillages and, so far as it is reasonable and practicable, be installed in a space appropriated solely for such equipment and their heaters.

(d) All internal combustion engines having an output of 2250 kilowatts or above or having cylinders of 300 millimetres bore or above shall be provided with crankcase oil mist detectors or engine bearing temperature detectors or other equivalent means which shall give an alarm on the alarm system in the event of an incipient dangerous condition.

(e) All air supply casings and uptakes of boilers and scavenge air belts of main propulsion engines shall be provided with detectors which shall give an alarm on the alarm system in the event of incipient fire occurring therein, unless the Certifying Authority waives the requirement for such provisions.

### ***Protection against flooding***

**9.(a)** The machinery space bilge wells shall be so located that an accumulation of liquid at normal angles of heel and trim may be detected and a liquid level alarm shall be provided. The machinery space bilge wells shall have sufficient capacity to accommodate normal drainage during unattended periods. Ships with automatic bilge pumping shall be provided with a means of indicating when the bilge pump is operating more frequently than during normal operation. When automatic bilge pumping is provided smaller bilge wells may be permitted by the Certifying Authority.

**(b)** The location of the controls of any valve serving a sea inlet, a discharge below the waterline or a bilge injection system shall be so sited as to allow adequate time for operation in the case of influx of water to the space, having regard to the time likely to be required to reach and operate such controls. If the level to which the space could become flooded with the ship in the fully loaded condition so requires, arrangements shall be made to operate the controls from a position above such a level.

***Regulation 47(4) and 49(2)***

## **SCHEDULE 10**

### **EMERGENCY AND TRANSITIONAL SOURCE OF ELECTRICAL POWER**

#### **Part 1 - Emergency and transitional source of electrical power**

**1.(a)** In every ship the emergency source of electrical power shall be capable of operating simultaneously for a period of at least 6 hours the following services

- (i)** the emergency lighting required by the Merchant Shipping (Life Saving Appliances for ships other than ships of Classes III to VI (A)) Regulations 1997 as appropriate;
- (ii)** an emergency lighting system which shall be provided in the main machinery spaces, the space containing the ship's main electric generating plant, on the navigating bridge and in the chartroom;
- (iii)** the general alarm, if electrically operated;

(iv) the ship's navigation lights if solely electric; and

(v) the daylight signalling lamp if it is operated by the ship's main source of electrical power.

Except that in ships of under 5000 tons the period shall be of at least 3 hours and subparagraphs 1(a)(ii) and 1(a)(v) do not apply.

(b) (i) In every ship the emergency source of electrical power shall be either accumulator (storage) batteries capable of complying with the requirements of subparagraph 1(a) without being recharged or suffering an excessive voltage drop, or a generator driven by internal combustion type machinery with an independent fuel supply and with efficient starting arrangements and the fuel provided for such machinery shall have a flashpoint of not less than 43°C.

(ii) The emergency source of electrical power shall be so arranged that it will operate efficiently when the ship is listed 22 ½ degrees and when the trim of the ship is 10 degrees from an even keel.

(iii) Provision shall be made for periodically testing the emergency source of power and its associated circuits.

***Ships constructed on or after 1st September 1984***

(c) Notwithstanding subparagraphs 1(a) and 1(b), every ship constructed on or after 1st September 1984 shall comply with subparagraph 1(d) to 1(o).

(d) Every ship shall be provided with a self-contained emergency source of electrical power which shall be so designed and arranged that it will operate at full rated power when the ship is listed 22 ½ degrees and when the trim of the ship is 10 degrees from an even keel or any combination of or up to these limits.

(e) The emergency source of electric power, the associated transforming equipment, any transitional source of emergency power required by subparagraph 1(g)(ii) the emergency switchboard and the emergency lighting switchboard shall be

(i) located above the uppermost continuous deck,

(ii) readily accessible from the open deck;

(iii) located aft of the collision bulkhead;

(iv) so arranged that a fire or other casualty in the spaces containing the main source of electrical power, the associated transforming equipment and the main switchboard or in any machinery space of Category A will not interfere with the supply control and distribution of emergency supplies; and

(v) located where practicable in a space which is not contiguous to the boundaries of a machinery space of Category A or any other space containing the main source of electrical power, the main switchboard or any associated transforming equipment.

(f) The emergency source of electrical power shall be a generating set complying with the requirements of subparagraph 1(g) or an accumulator battery complying with the requirements of subparagraph 1(i).

- (g)** Where the emergency source of electrical power is a generator it shall
- (i)** be driven by internal combustion machinery with an independent fuel supply having a flashpoint of not less than 43°C (Closed Cup Test); and
  - (ii)** be started automatically upon the failure of the main source of electrical power supply unless a transitional source of emergency electrical power is provided in accordance with subparagraph 1(j); if the emergency generator is arranged for automatic starting, the generator and the services that would otherwise be supplied from the transitional source of emergency electrical power in compliance with the requirements of subparagraphs 1(j)(iii) and 1(j)(iv) shall be automatically connected to the emergency switchboard so that such services will be supplied within 45 seconds of the failure of the main source of electrical power.
- (h)** The emergency generator may be used to supply services other than emergency supplies exceptionally for short periods provided that the independent operation of the emergency source of electrical power is safeguarded in all circumstances.
- (i)** Where the emergency source of electrical power is an accumulator battery it shall be-
- (i)** capable of supplying the emergency electrical load without being recharged, whilst maintaining the voltage of the battery throughout the required discharge period within 12 per cent of its nominal voltage;
  - (ii)** automatically connected to the emergency switchboard in the event of the failure of the main source of electrical power; and
  - (iii)** capable of immediately supplying the services specified in subparagraphs 1(j)(iii) and 1(j)(iv)
- (j)** The transitional source of emergency electrical power shall -
- (i)** consist of an accumulator battery capable of supplying the required services, without being recharged, whilst maintaining the voltage of the battery throughout the required discharge period within 12 per cent of its nominal voltage;
  - (ii)** be arranged to supply automatically the services required by subparagraphs 1(j)(iii) and 1(j)(iv) for at least half an hour in the event of the failure of either the main or emergency source of electrical power
  - (iii)** supply the lighting required by subparagraphs 3(b)(i), 3(b)(ii) and 3(b)(iv)(aa) except that permanently fixed, individual, automatically charged, relay operated accumulator lamps may be permitted for the transition phase in machinery, service and accommodation spaces; and
  - (iv)** supply the services required by subparagraphs 3(b)(iii)(aa), 3(b)(iii)(bb) and 3(b)(iii)(cc) unless a suitably located independent accumulator battery is provided capable of supplying such services for the period of time required by the those paragraphs.
- (k)** Discharge of accumulator batteries that constitute either the emergency or transitional source of electrical power shall be indicated on the main switchboard or in the machinery control room. Discharge of any independent accumulator batteries provided in compliance with subparagraph 3(b)(iii) shall be indicated at the appropriate control station.

**(l)** The emergency switchboard shall be situated as near as practicable to the emergency source of electrical power. If the emergency source of electrical power is a generator the emergency switchboard shall be situated in the same space as the generator unless the operation of the emergency switchboard would be thereby impaired. For the purposes of this paragraph an environmental enclosure within the main boundaries of the space does not provide separation between the emergency generator and the emergency switchboard. Any accumulator battery required by this Schedule shall not be installed in the same space as the emergency generator.

**(m)** The emergency switchboard shall be supplied during normal operation from the main switchboard by an interconnector feeder which shall be -

**(i)** adequately protected at the main switchboard against overload and short circuit;

**(ii)** disconnected automatically at the emergency switchboard upon the failure of the main source of electrical power; and

**(iii)** be at least protected against short circuit at the emergency switchboard if the system is arranged for the main switchboard to be supplied from the emergency switchboard.

**(n)** Arrangements shall be made to disconnect non-emergency circuits automatically from the emergency switchboard, if necessary, to ensure that electric power will be available for the required emergency supplies.

**(o)** Means shall be provided for testing the complete emergency system periodically including any automatic starting arrangements provided.

## **Part 2 - Starting arrangements for emergency generating sets**

### ***Requirements for ships constructed on or after 1st September 1984***

**2.(a)** Emergency generating sets shall be capable of being readily started at a temperature of 0°C. If temperatures below 0°C are anticipated provision shall be made for heating the engine so that it will start readily.

**(b)** The starting, charging and energy storing devices, which shall not be used for any purpose other than the operation of the emergency generating set, shall be located in the emergency generator space except that the air receiver of the emergency generator set may be supplied from the main or auxiliary compressed air system through a non-return valve located in the emergency generator space.

**(c)** The stored energy required for starting shall be maintained at all times

**(i)** in electrical and electro-hydraulic systems, from the emergency switchboard; and

**(ii)** in compressed air systems, by the main or auxiliary compressed air system or by an emergency air compressor which, if it is electrically driven, shall be supplied from the emergency switchboard.

**(d)** Subject to subparagraph 2(f), any emergency generating set arranged to be automatically started shall

**(i)** be equipped with a starting system having sufficient stored energy for three consecutive starts; and

(ii) be provided with an additional source of stored energy independent of the starting system required by subparagraph 2(d)(i) capable of producing a further three starts within 30 minutes unless an alternative and independent starting system is provided or effective manual starting can be demonstrated.

(e) Any emergency generator that is not arranged for automatic starting shall either

(i) be provided with starting arrangements in accordance with the requirements of subparagraph 2(d) except that the starting may be initiated manually; or

(ii) be started manually by cranking, inertia starters or manually charged hydraulic accumulators, provided that at least three starts can be accomplished within 30 minutes.

#### ***Additional requirements for ships constructed on or after 1st October 1994***

(f) The following requirements shall apply instead of subparagraph 2(d) -

(i) any emergency generating set arranged to be automatically started shall -

(aa) be equipped with a starting system having sufficient stored energy for three consecutive starts. The source of stored energy shall be protected to preclude critical depletion by the automatic starting system, unless a second independent source of energy is provided; and

(bb) be provided with a second source of stored energy for an additional three starts within 30 minutes, unless an alternative and independent starting system capable of three starts within 30 minutes is provided or effective manual starting can be demonstrated.

### **Part 3 - Emergency supplies**

#### ***Requirements for ships constructed on or after 1st September 1984***

**3.(a)** In this part "the Radio Regulations" mean the Merchant Shipping (Radio Installations) Regulation 1992 <sup>(a)</sup>.

(b) The emergency source of electric power required by subparagraph (i)(f) shall be capable of simultaneously supplying the following services, including any starting currents

(i) for a period of 3 hours, the emergency lighting required by -

(aa) regulation 34(3)(a) and 34(3)(b) of the Merchant Shipping (Life-Saving Appliances) for ships other than Ships of Classes III to VI (A) Regulations 1997;

(bb) regulations 50(4), 50(5) and 53(8) of the Merchant Shipping (Life-Saving Appliances) for ships other than ships of Classes III to VI (A) Regulations 1997;

whichever is applicable;

(ii) for a period of 18 hours, emergency lighting

---

<sup>a</sup> SI 1992/3

- (aa) in all service and accommodation alleyways, stairways, exits, lifts and lift shafts;
  - (bb) in machinery spaces and main generating stations including the control positions;
  - (cc) in control stations, machinery control rooms and at each main and emergency switchboard;
  - (dd) at the stowage positions for firemen's outfits;
  - (ee) at the steering gear; and
  - (ff) at the fire pump, sprinkler pump and emergency bilge pump and at their starting positions;
- (iii) for a period of 18 hours, unless they have an equivalent independent supply from a suitably located accumulator battery
- (aa) the general alarm,
  - (bb) the fire detection and fire alarm system;
  - (cc) the daylight signalling lamps, ship's whistle and manually operated call points, intermittently; and
  - (dd) the navigational equipment required by regulation 3 of the Merchant Shipping (Navigational Equipment) Regulations 1993(a), on ships of 5,000 tons or more;
- (iv) for a period of 18 hours -
- (aa) the navigation lights; and
  - (bb) any fire pumps which depend upon the emergency generator for their source of power in compliance with the Merchant Shipping (Fire Protection: Large Ships) Regulations 1997; and
  - (cc) on ships constructed on or after 1st February 1995 the VHF radio installation required by regulation 8(1)(a) and (b) of the Radio Regulations, and, if applicable
    - (1) the MF radio installation require a by regulations 10(1)(a), 10(1)(b), 11(1)(Alternative A)(b), and 11(1)(Alternative A)(c) of the Radio Regulations;
    - (2) the ship earth station required by regulation 11(1) (Alternative A)(a) of the Radio Regulations; and
    - (3) The MF/HF radio installation, required by regulations 11(1)(Alternative B)(a), 11(1)(Alternative B)(b) and 12 of the Radio Regulations.
- (v) for the time required by subparagraph 1(t) of Schedule 6, the steering gear; and
- (vi) for a period of 30 minutes, the ship's watertight doors if they are electrically driven or electro-hydraulically operated, together with their indicators which show whether the doors are open or closed, and warning signals if they are electrically operated.

(c) A reduction of the periods of time specified in subparagraphs 3(b)(ii), 3(b)(iii) and 3(b)(iv) may be permitted by the Certifying Authority in any ship plying regularly on voyages of short duration, provided that it is not less than 12 hours.

## ***Regulation 51***

### **SCHEDULE 11**

#### **GENERAL PRECAUTIONS AGAINST SHOCK, FIRE AND OTHER HAZARDS**

**1.** In every ship all electrical equipment shall be so constructed and installed that there will be no danger of injury to any person handling it in a proper manner. Exposed metal parts of electrical equipment which are not intended to have a voltage above that of earth but which may have such a voltage under fault conditions shall be earthed unless such equipment is -

(a) supplied at a voltage not exceeding 50 volts direct current or 50 volts root mean square alternating current between conductors, hereinafter referred to as "RMS a.c.", from a source other than an auto-transformer;

(b) supplied at a voltage not exceeding 250 volts RMS, a.c. by safety isolating transformers supplying only one consuming device; or

(c) of double insulation construction.

**2.** All electrical apparatus shall be constructed and installed so that it will not cause injury when handled or touched in the normal manner. When electric lamps, welding equipment, tools or other apparatus are used in confined damp spaces or spaces with a large exposed conductive surface, special provision shall be made so far as is practicable, to ensure that the danger of electric shock is reduced to a minimum. Such spaces shall at least include open decks and machinery spaces.

**3.** Every main and emergency switchboard shall be so arranged as to give easy access for operation and sufficient access for maintenance without danger to any person. Every such switchboard shall be suitably guarded and a non-conducting mat or grating shall be provided at the back and the front where necessary. No exposed parts which may have a voltage between conductors or to earth exceeding 250 volts direct current or 50 volts RMS, a.c. shall be installed on the face of any switchboard or control panel.

**4.** Subject to paragraph 5, the hull return system of distribution shall not be used for any purpose in a tanker, chemical tanker or gas carrier or for power, heating or lighting in any other ship of 1600 tons or over.

**5.** The requirements of paragraphs 4 and 6 do not preclude the use of -

(a) impressed current cathodic protection system;

(b) limited and locally earthed systems provided that, in the case of ships constructed on or after 1<sup>st</sup> October 1994, any possible resulting current does not flow directly through hazardous areas; and

(c) insulation monitoring devices with a maximum circulation current of 30 milliamperes.

6. The final sub-circuits of any hull return system of distribution shall be two wire.
7. Every separate electrical circuit shall be protected against short circuit.
8. Each separate electrical circuit, other than a circuit which operates the ship's steering gear or any other circuit in respect of which the Secretary of State grants an exemption shall be protected against overload. There shall be clearly and permanently indicated on or near each overload protective device the current carrying capacity of the circuit which it protects and the rating or setting of the device.
9. Accumulator batteries shall be housed in boxes or compartments which are constructed to protect the batteries from damage and are ventilated to minimise the accumulation of explosive gas. Subject to paragraph 1 of Schedule 12 electrical or other equipment which may constitute a source of ignition of flammable vapours shall not be installed in any compartment assigned to accumulator batteries. Accumulator batteries shall not be installed in sleeping accommodation spaces.
10. Every electric space-heater forming part of the equipment of a ship shall be fixed in position and shall be so constructed as to reduce the risk of fire to a minimum. No such heater shall be constructed with an element so exposed that clothing, curtains, or other material can be scorched or set on fire by heat from the elements.

***Additional requirements of ships constructed on or after 1st September 1984***

11. Subject to paragraph 14, earthed distribution systems shall not be installed in any tanker, chemical tanker or gas carrier except that the neutral of an alternating current distribution system with a line voltage of 3000 volts or over may be earthed if any current therefrom does not flow directly through any hazardous areas.
12. The insulation of any distribution system that is not earthed shall be continuously monitored by a system capable of giving audible or visual indication of abnormally low insulation values.
13. All lighting and power circuits terminating in a bunker or cargo space shall be provided with a multiple pole switch outside the space for disconnecting all such-circuits.

***Additional requirements for ships constructed, on or after 1st October 1994***

14. The following requirements shall apply instead of paragraph 11 -
  - (a) except as permitted by subparagraph (b), earthed distribution systems shall not be used in a tanker;
  - (b) the requirement of subparagraph (a) does not preclude the use of earthed intrinsically safe circuits and in addition, under conditions approved by the Certifying Authority, the use of the following earthed systems
    - (i) power-supplied control circuits and instrumentation circuits where technical or safety reasons preclude the use of a system with no connection to earth, provided the current in the hull is limited to not more than 5 A in both normal and fault conditions; or
    - (ii) limited and locally earthed systems, provided that any possible resulting current does not flow directly through any of the hazardous areas; or

(iii) alternating current power networks of 1,000 volts RMS (line to line) or over, provided that any possible resulting current does not flow directly through any of the hazardous areas.

**Regulation 52**

**SCHEDULE 12**

**ELECTRICAL EQUIPMENT IN HAZARDOUS AREAS AND SPACES**

***Requirements for ships constructed on or after 1st September 1984***

1. Electrical equipment shall not be installed in any hazardous area unless the Certifying Authority is satisfied that such equipment is -

(a) essential for operational or safety purposes;

(b) of a type that is certified for use in the flammable dusts, gases or vapours to which it may be subjected; and

(c) appropriate to the space concerned.

2. Cables passing through any hazardous areas or serving electrical equipment in such areas shall -

(a) be appropriate for use in the dusts, gases or vapours to which they may be subject; and

(b) unless they form part of intrinsically safe circuits, include a metallic sheath or a braid or wire armour for earth leakage detection, unless they are enclosed in a gas-tight steel conduit. Additional protection against mechanical damage shall be provided in locations where such damage may occur.

3.(a) The electrical equipment in enclosed cargo spaces intended for the carriage of motor vehicles with fuel in their tanks for their propulsion in any ventilation trunk for such spaces shall be of a type that is certified for use in explosive petrol and air mixtures.

(b) Electrical equipment that is enclosed and protected to prevent discharge of sparks may be installed in such cargo spaces more than 450 millimetres above any deck on which vapours may accumulate if the atmosphere within the cargo space is changed at least ten times per hour.

4. The cables installed in enclosed cargo spaces intended for the carriage of motor vehicles with fuel in their tanks for their propulsion and in any ventilation trunks to such spaces shall be appropriate for use in explosive petrol and air mixtures.

5. Electrical equipment and cables shall not be installed in enclosed cargo spaces or open vehicle deck spaces intended for the carriage of packaged dangerous goods other than those of Classes 4.1, 4.2, 4.3, 5.1, 5.2 and 7, as detailed in regulation 7(2) of the Merchant Shipping (Dangerous Goods and Marine Pollutants) Regulations 1990, or the carriage of solid dangerous goods in bulk, other than those of Classes 6.1, 7 and 8 as detailed in the aforesaid Regulations unless the Marine Safety Agency considers their location therein essential. If permitted, any

electrical equipment installed in such spaces shall be certified for, and the cables shall be appropriate for, use in the flammable dusts, gases or vapours to which they may be exposed. Cable penetrations of the decks and bulkheads of such spaces shall be sealed against the passage of gas or vapour. The Marine Safety Agency may permit the isolation of electrical equipment and cables which do not comply with the foregoing for particular applications provided such equipment and cables are capable of being electrically isolated by the removal of links or the operation of lockable switches.

***Regulation 54***

### **SCHEDULE 13**

### **EMERGENCY TOWING ARRANGEMENTS FOR TANKERS**

***Purpose***

1. New and existing tankers of 20,000 tonnes deadweight and above shall be fitted with an emergency towing arrangement, the design and construction of which shall be approved by the Certifying Authority General

**Requirements for the Arrangements and Components**

**General**

2.(a) The emergency towing arrangements shall be so designed as to facilitate salvage and emergency towing operations on tankers primarily to reduce the risk of pollution. The arrangements shall at all times be capable of rapid deployment in the absence of main power on the ship to be towed and easy connection to the towing vessel. Figure 5 shows arrangements which may be used as reference.

**Towing components**

(b) The major components of the towing arrangements shall consist of the following-

	<b>Forward of Ship</b>	<b>Aft of Ship</b>	<b>Strength requirements</b>
Pick-up gear	optional	Yes	-
Towing pennant	optional	Yes	Yes
Chafing gear	Yes	Depending on design	Yes
Fairlead	Yes	Yes	Yes
Strongpoint	Yes	Yes	Yes
Roller pedestal	Yes	Depending on design	-

**Strength of the towing components**

(c)(i) Towing components as specified in subparagraph 2(b) for strength shall have a working strength of at least 1,000 kN for tankers of 20,000 tonnes deadweight or over but less than 50,000 tonnes deadweight, and at least 2,000 W for tankers of 50,000 tonnes deadweight or over (working strength is defined as one half ultimate strength). The strength shall be sufficient for all relevant angles of towline, i.e. up to 90 degrees from the ship's centreline to port and starboard and 30 degrees vertical downwards.

(ii) Other components shall have a working strength sufficient to withstand the load to which such components may be subjected during the towing operation.

**Length of towing pennant**

(d) The towing pennant shall have a length of at least twice the lightest seagoing ballast freeboard at the fairlead plus 50 metres.

**Location of strongpoint and fairlead**

(e) The bow and stem strongpoint and fairleads shall be located so as to facilitate towing from either side of the bow or stem and minimize the stress on the towing system.

**Strongpoint**

(f) The inboard end fastening shall be a stopper or bracket or other fitting of equivalent strength. The strongpoint can be designed integral with the fairlead.

## **Fairleads**

### **Size**

- (g) (i) Fairleads shall have an opening large enough to pass the largest portion of the chafing gear, towing pennant or towing line.

### **Geometry**

- (ii) The fairlead shall give adequate support for the towing pennant during towing operation which means bending 90 degrees to port and to starboard side and 30 degrees vertical downwards. The bending ratio (towing pennant bearing surface diameter to towing pennant diameter) should be not less than 7 to 1.

### **Vertical location**

- (iii) The fairlead shall be located as close as possible to the deck and, in any case, in such a position that the chafing chain is approximately parallel to the deck when it is under strain between the strongpoint and the fairlead.

## **Chafing chain**

- (h) The chafing gear shall have the following characteristics

### **Type**

- (i) The chafing chain shall be stud link chain;

### **Length**

- (ii) The chafing chain shall be long enough to ensure that the towing pennant remains outside the fairlead during the towing operation. A chain extending from the strongpoint to a point at least 3 metres beyond the fairlead should meet this criterion;

### **Connecting limits**

- (iii) One end of the Chafing chain shall be suitable for connection to the strongpoint. The other end shall be fitted with a standard pear-shaped open link allowing connection to a standard bow shackle; and

## **Stowage**

- (iv) The chafing chain shall be stowed in such a way that it can be rapidly connected to the strongpoint.

## **Towing connection**

- (i) The towing pennant shall have a hard eye-formed termination allowing connection to a standard bow shackle.

## **Prototype test**

(j) Designs of emergency towing arrangements in accordance with these Guidelines shall be prototype tested to the satisfaction of the Secretary of State.

### **Ready Availability of Towing Arrangements**

3. To facilitate approval of such equipment and to ensure rapid deployment, emergency towing arrangements shall comply with the following criteria

(a) the aft emergency towing arrangement shall be pre-rigged and be capable of being deployed in a controlled manner in harbour conditions in not more than 15 minutes;

(b) the pick-up gear for the aft towing pennant shall be designed for manual operation by one person taking into account the absence of power and the potential for adverse environmental conditions that may prevail during such emergency towing operations. The pick-up gear shall be protected against the weather and other adverse conditions that may prevail;

(c) the forward emergency towing arrangement shall be capable of being deployed in harbour conditions in not more than 1 hour;

(d) the forward emergency towing arrangement shall have be designed at least with a means of securing a towline to the chafing gear using a suitably positioned pedestal roller to facilitate connection of the towing pennant;

(e) forward emergency towing arrangements which comply with the requirements for aft emergency towing arrangements may be accepted;

(f) all emergency towing arrangements shall be clearly marked to facilitate safe and effective use even in darkness and poor visibility; and

(g) all emergency towing components shall be inspected by ship personnel at regular intervals and maintained in good working order.

Figure: 1  
Test Rig for Flash Back Test

- 1 - bursting diaphragm (plastic)
- 2 - explosive mixture inlet
- 3 - tank
- 4 - flame arresting device
- 5 - plastic foil bag
- 6 - ignition sources

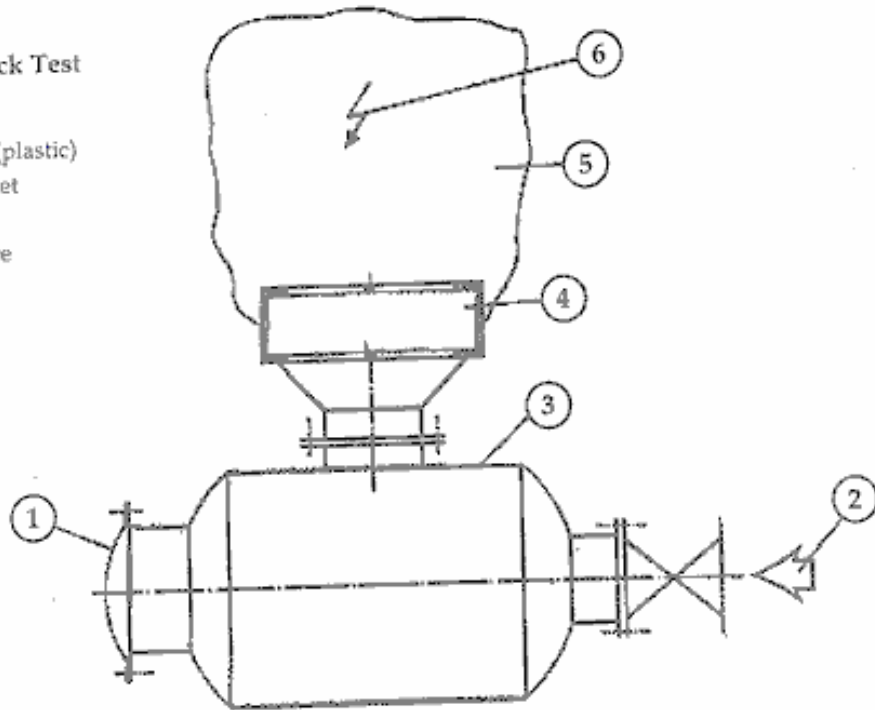
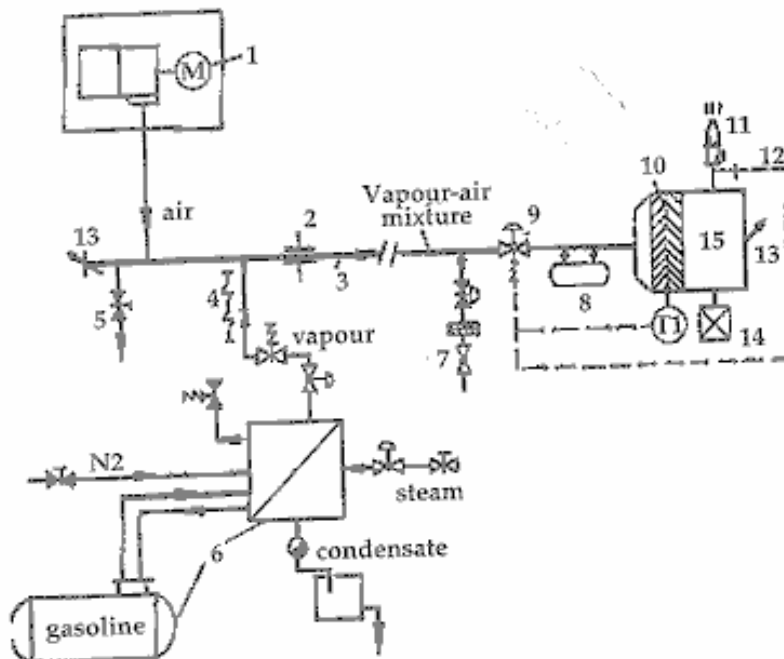
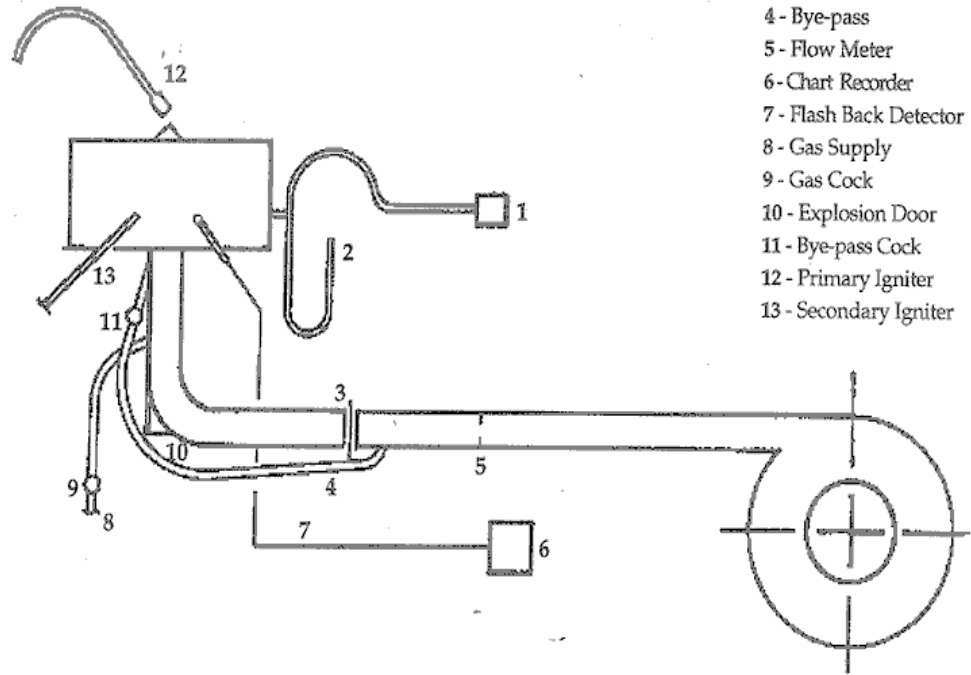

Figure: 2  
Schematic Plan of the Test Plant for High Velocity Vents  
(endurance burning test only)



- 1 - fan with variable speed
- 2 - volume rate indicator
- 3 - pipe (500 mm diameter), length - 30 m
- 4 - heated vapour pipe
- 5 - air bypass
- 6 - evaporator and liquid storage tank
- 7 - vapour/air-mixture bypass
- 8 - extinguishing agents
- 9 - control and quick action valve
- 10 - explosion arresting crimped ribbon with temperature control for the safety of the test plant
- 11 - high velocity valve to be tested
- 12 - flame detector
- 13 - bursting diaphragm
- 14 - concentration indicator
- 15 - tank

Figure: 3  
Test Rig for High Velocity Vents



- 1 - Gas Analyser
- 2 - Manometer
- 3 - Spade Blank
- 4 - Bye-pass
- 5 - Flow Meter
- 6 - Chart Recorder
- 7 - Flash Back Detector
- 8 - Gas Supply
- 9 - Gas Cock
- 10 - Explosion Door
- 11 - Bye-pass Cock
- 12 - Primary Igniter
- 13 - Secondary Igniter

Figure: 4  
Test Rig for Flame Arrestors located in-Line

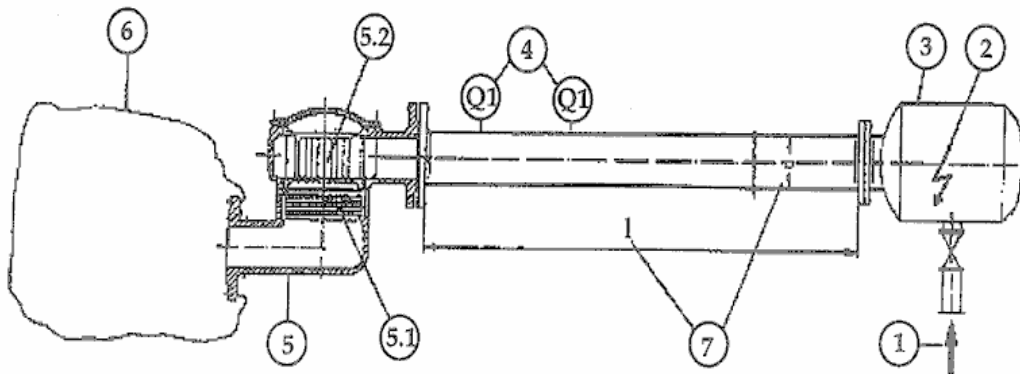

- 1 - explosives mixture inlet
- 2 - ignition source; ignition within nonstreaming mixture
- 3 - tank
- 4 - measuring system for flame speed of a stable detonation
- 5 - flame arrestor located in-line
- 5.1 - flame arrestor element
- 5.2 - shock wave absorber
- 6 - plastic foil bag
- 7 -  $l/d = 100$

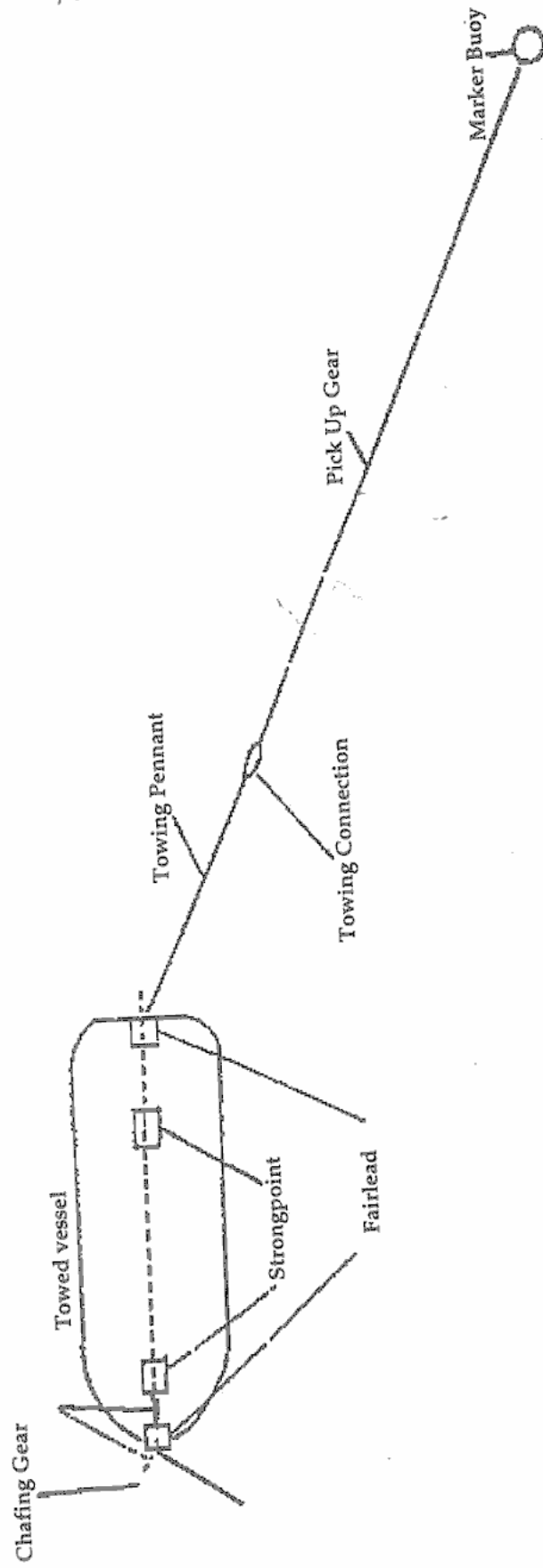

Figure 5  
 Typical Emergency Towing Arrangements