

INTERIM ADVICE NOTE 73/06 Revision 1 (2009)

DESIGN GUIDANCE FOR ROAD PAVEMENT FOUNDATIONS (DRAFT HD25)

SUMMARY

This interim advice note provides design guidance for road pavement foundations.

INSTRUCTIONS

This IAN takes immediate effect. It supersedes HD 25/94 and also IAN 73/06 including the Specification Clauses and Notes for Guidance clauses that were included in IAN 73/06. It should be read in conjunction with HD 26/06

Contents

Section 1	Background
Section 2	Implementation
Section 3	Departures from Standard
Section 4	Draft Standard HD 25
Section 5	Draft Specification Clauses
Section 6	Draft Notes for Guidance Clauses

Section 1. Background

This Interim Advice Note provides design guidance for road pavement foundations. Road pavement upper layers are now subject to design methods and criteria that have been published in HD 26/06. The method is based on a classification for road pavement foundations that are separated into four Foundation Classes. The design guidance contained in this Interim Advice Note (presented as the draft HD 25) defines the four Foundation Classes and describes the methods to be used in their design and the testing regime associated with the design. It is published in this interim form to ensure that all road pavements may be designed in a coordinated manner using both HD 26/06 and the guidance in this IAN. The guidance has been produced in the form of a draft standard to replace HD 25/94, together with draft Specification and Notes for Guidance clauses that will be included in the MCHW. **The Standard HD 25/94 (DMRB 7.2.2) and IAN 73/06 are now withdrawn.** The new foundation classes are presented in two forms: 'Performance Designs' that allow a wide use of materials together with measures and testing to ensure design requirements are met and also 'Restricted Designs' that are included for schemes where performance testing may not be appropriate. The Guidance is included in this Interim Advice Note in 3 sections

Section 4.	Draft Standard HD 25 'Pavement Foundations'
Section 5.	Draft Specification Clauses 890 to 896
Section 6.	Draft Notes for Guidance Clauses NG890 to NG896

This revision to IAN 73/06 has been produced following comment received and a further review of the original text. The Chapters have been reorganised and the text updated.

Section 2. Implementation

This Interim Advice Note shall be used forthwith on all future schemes for the construction, improvement and maintenance of trunk roads. It shall apply also to all those schemes that are in preparation provided that, in the opinion of the Overseeing Organisation, this will not result in significant additional expense or delay progress. Design Organisations shall confirm its application to particular schemes with the Overseeing Organisation.

Section 3. Departures from Standard

The design guidance for pavement foundations included in this Interim Advice Note is presented into two separate chapters. The Restricted Designs included in Chapter 3 of Section 4 may be used by designers without reference to the Overseeing Organisation. The Performance Designs included in Chapter 4 of Section 4 should be referred to the Overseeing Organisation for approval under the Departure from Standards procedure. It is the intention that this will be required for an interim period until the guidance is published as a Standard in the DMRB and the Specification/Notes for Guidance clauses are published in the MCHW.

Section 4. Draft Design Standard HD 25 Pavement Foundations

Replaces previous HD 25/94 and IAN 73/06

Contents

Chapter

1. Introduction
2. Background
3. Restricted Foundation Designs
4. Performance Foundation Designs
5. Characterisation of Materials
6. Drainage and Frost
7. Testing
8. References

Annex A: Equations of Thickness Design Examples – Performance Foundation Design

Annex B: Procedure for Alternative Performance Foundation Designs

Annex C: Performance Foundation Design procedure – Flowcharts and Examples

Chapter 1. INTRODUCTION

General

- 1.1 The main purpose of the foundation is to distribute the applied vehicle loads to the underlying subgrade, without causing distress in the foundation layers or in the overlying layers. This is required both during construction and during the service life of the pavement.

Scope

- 1.2 This Part covers the design of pavement foundations in order to achieve the Foundation Classes called up in HD26.
- 1.3 The four Foundation Classes are defined by the Foundation Surface Modulus value (see Paragraph 2.1 for modulus definitions) used for design purposes, as follows:
- Class 1 $\geq 50\text{MPa}$
 - Class 2 $\geq 100\text{MPa}$
 - Class 3 $\geq 200\text{MPa}$
 - Class 4 $\geq 400\text{MPa}$
- 1.4 The materials covered by this Part are the subgrade, either natural ground or compacted fill, unbound capping materials and stabilised capping materials as defined in Series 600 of the Specification (MCHW1), and hydraulically bound subbase mixtures (including stabilised soils) or granular subbase mixtures as defined in Series 800 of the Specification. Further definitions can be found in HD23 (DMRB 7.1.1).
- 1.5 Two design approaches are presented. The first allows a limited number of Restricted Foundation Designs to be applied for Foundation Classes 1, 2 and 3 and is particularly intended for use on schemes of limited extent. The designs are conservative, making allowances for uncertainty in material performance and in layer thickness.
- 1.6 The second approach is for Performance Foundation Designs. These cover all four Foundation Classes and provide more flexibility to the designer. The main acceptance criterion for construction of a Performance Design is the in-situ Foundation Surface Modulus, measured immediately prior to the placement of the overlying pavement layers. A design method is provided with examples of how the four foundation classes might be achieved. Some duplication between the different design options has been included in order that each procedure can be read independently.
- 1.7 The choice as to which approach and which Foundation Class is selected is usually made on economic grounds based on the materials that are available, the size of the scheme and relevant costing information. It is expected that designers will give full consideration to the use of local and secondary materials.
- 1.8 All Performance Designs will be subject to approval under a Departure from Standards. Performance Designs must only be used in conjunction with the Performance Related Specification for Foundations, as given in Draft Clauses 890 onwards in Section 5 of this Interim Advice Note.

- 1.9 Performance Designs recognise that not all materials have equal engineering properties and permit designers to take advantage of improved foundation materials by reducing the thickness of overlying layers. The resulting designs are minimum thickness requirements to achieve the design assumptions, with no allowance for construction tolerance. (Also see Paragraph 4.54)
- 1.10 The important role of drainage in achieving good long-term pavement performance is also highlighted and key requirements are given in Chapter 6 of this Section.
- 1.11 Issues with regard to frost penetration are also covered, with respect to their effect on foundation durability.
- 1.12 Chapter 7 on test methods is included for general information. The particular tests required by the Performance Related Specification for Foundations are detailed in Chapters 5 and 6.

Interim Advice

Chapter 2. BACKGROUND

DEFINITIONS

2.1 The following expressions used in this standard are defined below. Also see Figure 2.1.

Stiffness Modulus: the ratio of applied stress to induced strain.

Foundation Surface Modulus: a measure of 'Stiffness Modulus' based on the application of a known load at the top of the foundation; it is a composite value with contributions from all underlying layers.

Subgrade Surface Modulus: an estimated value of 'Stiffness Modulus' based on subgrade CBR and used for foundation design.

Layer Modulus: a measure of 'Stiffness Modulus' assigned to a given foundation layer; usually, this is a long term estimate that will take account of degradation due to factors such as cracking.

Element Modulus: a measure of 'Stiffness Modulus' assigned to a discrete sample of material and usually characterised by a laboratory test; it does not normally take account of degradation due to factors such as cracking.

Mean Foundation Surface Modulus: the value that must be equalled or exceeded by the moving mean of five consecutive in-situ Foundation Surface Modulus measurements carried out in accordance with Clauses 890, 891, 892 and 895 of the Specification.

Minimum Foundation Surface Modulus: the value that must be exceeded by all individual measurements of in-situ Foundation Surface Modulus, when measured in accordance with Clauses 890, 891, 892 and 895 of the Specification.

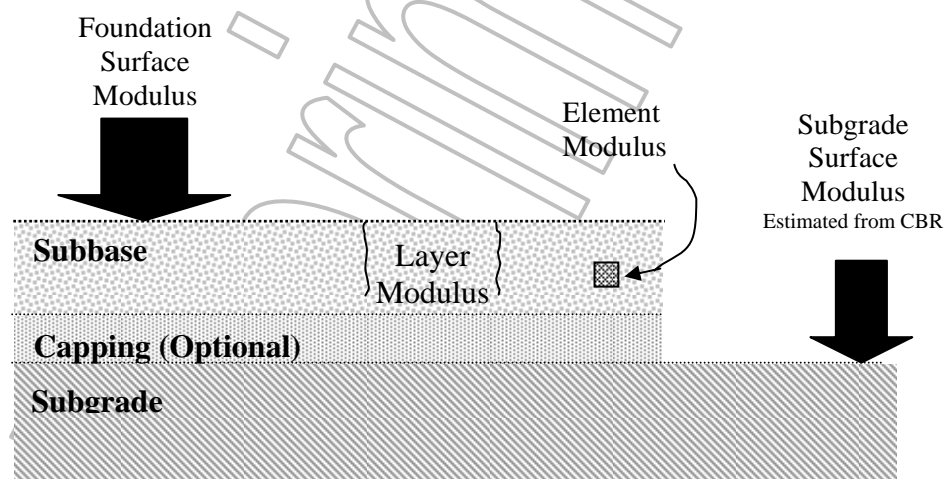

Figure 2.1 Modulus Definitions

- 2.2 Great care should be taken not to confuse the Layer Modulus with the Foundation Surface Modulus, as values will not generally be similar. For example, a Class 2 foundation with 100MPa Foundation Surface Modulus may comprise an upper layer with a Layer Modulus of 150 MPa over a subgrade with a Subgrade Surface Modulus of 60 MPa.
- 2.3 The design procedure adopted in this standard establishes groups of materials. These Mixture Groups are defined as follows:

Unbound: mixtures included in Specification Series 800 such as Clause 803 Type 1 Unbound Mixtures, Clause 804 Type 2 Unbound Mixtures, Clause 805 Type 3 (open graded) Unbound Mixtures, Clause 806 Category B (close graded) Unbound Mixtures and in Specification Series 600 including Clause 613 Capping Material Types 6F1, 6F2, 6F3, 6F4, 6F5 and 6S.

Fast-setting: bound mixtures that achieve more than 50 per cent of their specified compressive strength class after 28 days curing at 20 degrees C.

Slow-setting: bound mixtures that achieve 50 per cent or less of their specified strength class after 28 days curing at 20 degrees C.

ROLE OF FOUNDATION

During Construction

- 2.4 The stresses in the foundation are relatively high during construction, although the number of stress repetitions from construction traffic is relatively low and traffic is not as channelised as during the in-service life of the pavement.
- 2.5 During pavement construction, it is expected that loads will be applied to the foundation by delivery vehicles, pavers and other construction plant. At any level where such loading is applied, the strength and material thickness have to be sufficient to withstand the load without damage occurring that might adversely influence, to any significant extent, the future performance of the pavement.
- 2.6 Foundation layers also have to be either protected from, or to be of sufficient durability to withstand environmental effects from rain, frost, high temperature etc, without sustaining damage.
- 2.7 Damage may take the form of rutting or other uneven deformation, cracking in hydraulically bound mixtures (including stabilised soils), or other forms of material-specific degradation.
- 2.8 The designs given in this Draft HD 25, in conjunction with the tests and material restrictions given in the Specification, are intended to ensure that, under normal construction conditions, such damage is avoided.
- 2.9 The foundation also has to be of sufficient stiffness for the overlying pavement layers to be placed and adequately compacted.

In Service

- 2.10 During the life of a pavement, its foundation has to be able to withstand large numbers of repeated loads from traffic. It is also likely to experience ingress of water, particularly if the upper pavement materials begin to deteriorate towards the end of their design lives.
- 2.11 It is essential that the Foundation Surface Modulus assumed in the design, and relating to the choice of Foundation Class, is maintained throughout the life of the pavement. If this is not the case, deterioration of the upper pavement layers would typically occur more rapidly than assumed.
- 2.12 It is also essential that excessive deformation does not accumulate within the foundation under repeated traffic loading, since this is a potential source of wheelpath rutting at the pavement surface.
- 2.13 The performance of the foundation will also depend on the design, construction and maintenance of the earthworks and associated drainage system. HA 44 (DMRB 4.1.1) provides earthworks information and Chapter 6 of this Section provides further information on drainage. It is essential that the drainage system ensures that there is no accumulation of water in the pavement and foundation layers and that all excess moisture is allowed to disperse.

Chapter 3. RESTRICTED FOUNDATION DESIGNS

APPLICABILITY

- 3.1 The designs given in this chapter are intended for use in cases where it is inappropriate to carry out the range of compliance testing required by the Performance Related Specification for Foundations. For this reason they are conservative and recognize the greater uncertainty present in material properties when subjected to more limited testing.
- 3.2 Designs are not included for Foundation Class 4 since it is considered essential to measure the properties of such a foundation during construction to give adequate assurance that the appropriate long-term Foundation Surface Modulus is likely to be achieved.
- 3.3 Where bound subbase mixtures are permitted in Restricted Designs they have been restricted to those using CEM1 (EN 197:1) as the primary binder, acknowledging the greater uncertainty and lesser experience at present in the UK with other hydraulic binders and the consequent need for testing to be carried out.
- 3.4 The information to be collected during construction of the pavement foundation and covered by the Specification includes:
- Strength measurement (CBR value) at the top of the exposed subgrade, immediately prior to placement of the overlying foundation layers, throughout the Works;
 - Material density and the actual thickness for each stage of foundation construction, throughout the Works;
 - Compliance with the relevant material specifications from Specification Series 600 and 800 at each stage of foundation construction, throughout the Works;

SUBGRADE REQUIREMENTS

- 3.5 For design purposes, the Subgrade Surface Modulus must be estimated from CBR values using the procedure given in Chapter 5 (paragraphs 5.3 to 5.11). The Subgrade Surface Modulus used for design must be determined using the lowest value of the long term and short term CBR.
- 3.6 The Subgrade Surface Modulus for design and associated Design CBR must be stated by the Designer in Appendix 7/1 for each foundation area. These values must not be increased after construction has started.
- 3.7 Other methods for estimation of Subgrade Surface Modulus will be permitted with a Departure from Standards, provided that a satisfactory correlation with the reference method can be demonstrated.
- 3.8 The subgrade CBR value must be checked on site before foundation construction starts, in accordance with Clause 893 of the Specification (also see Paragraphs 5.12 to 5.15) and must be equal to, or be greater than, the Design CBR.
- 3.9 If the in-situ CBR is found to be less than the Design CBR, then the subgrade must either be improved to the Design CBR or the foundation redesigned.

- 3.10 Where the in-situ subgrade has an estimated CBR value less than 2.5 per cent, it must be improved as described in Chapter 5 (paragraphs 5.16 to 5.21) and its Design CBR must be based on the statements in those paragraphs.

THICKNESS DESIGN

- 3.11 Required thicknesses for Restricted Designs are shown in Figures 3.1 and 3.2.
- 3.12 Restricted Designs are included for Foundation Class 1, but these are not permitted for use on Trunk Roads including Motorways where pavements are designed for more than 20msa. This is because of the increased likelihood of damage during construction. Assurance against this would require Performance Design and use of the Performance Related Specification for Foundations.
- 3.13 Foundation Class 1 designs may make use of any of the capping options given in Table 6/1 in Series 600 of the Specification. The finished surface of the foundation must meet the criteria for subbase in Series 700 of the Specification.
- 3.14 For Class 2 foundations, there are four different design options depending on whether unbound or bound subbase is chosen and whether a capping is used.
- 3.15 Foundation Class 2 designs may make use of granular subbase mixtures to Clause 803, 805 and 806, Cement Bound Granular Mixtures to Clause 821 and 822 and Soil Cement to Clause 840. Cement Bound Granular Mixtures and Soil Cements must achieve compressive strength classes of at least C3/4. Granular subbase mixtures to Clause 804 (Subbase Type 2) may also be used for pavement with design traffic levels up to 5msa.
- 3.16 For Class 2, a capping may also be incorporated as part of the foundation (See Figure 3.2). For all Foundation Classes, using a layer of capping material brings practical benefits by providing a working platform and a good base for compaction of the overlying layers, which may be particularly appropriate for lower strength subgrades. A layer of suitable unbound material below a bound foundation layer also provides a drainage path, see Chapter 6.
- 3.17 Foundation Class 3 designs are restricted to those using Cement Bound Granular Mixtures to Clause 821 and 822 achieving at least the compressive strength class C8/10.
- 3.18 Figures 3.1 and 3.2 are referenced to both Subgrade surface stiffness values (in MPa) and to CBR values for consistency with previous standards and comparison with Performance Designs. The relationship between CBR and Stiffness Modulus is that given in Chapter 5.
- 3.19 Design thicknesses are to be rounded up to the nearest 10 mm.
- 3.20 Thicknesses derived for these Restricted Designs are subject to the normal construction tolerances as given in Series 700 of the Specification (MCHW1).

Design Example 1

Subgrade Surface Modulus for design estimated as 40MPa (approximately 3.5% CBR); the following Restricted Design options exist:

Foundation Class 1 (Specification Series 600 materials; Figure 3.1):

- 465 rounded up to **470 mm**

Foundation Class 2 (CBGM A or B, C3/4 Figure 3.1):

- 305 rounded up to **310 mm**

Foundation Class 2 (Types 1, 2, 3 or Category B subbase on capping; Figure 3.2):

- **290mm** subbase + **230mm** capping

Foundation Class 3 (CBGM A or B C8/10; Figure 3.1):

- 305 rounded up to **310 mm**

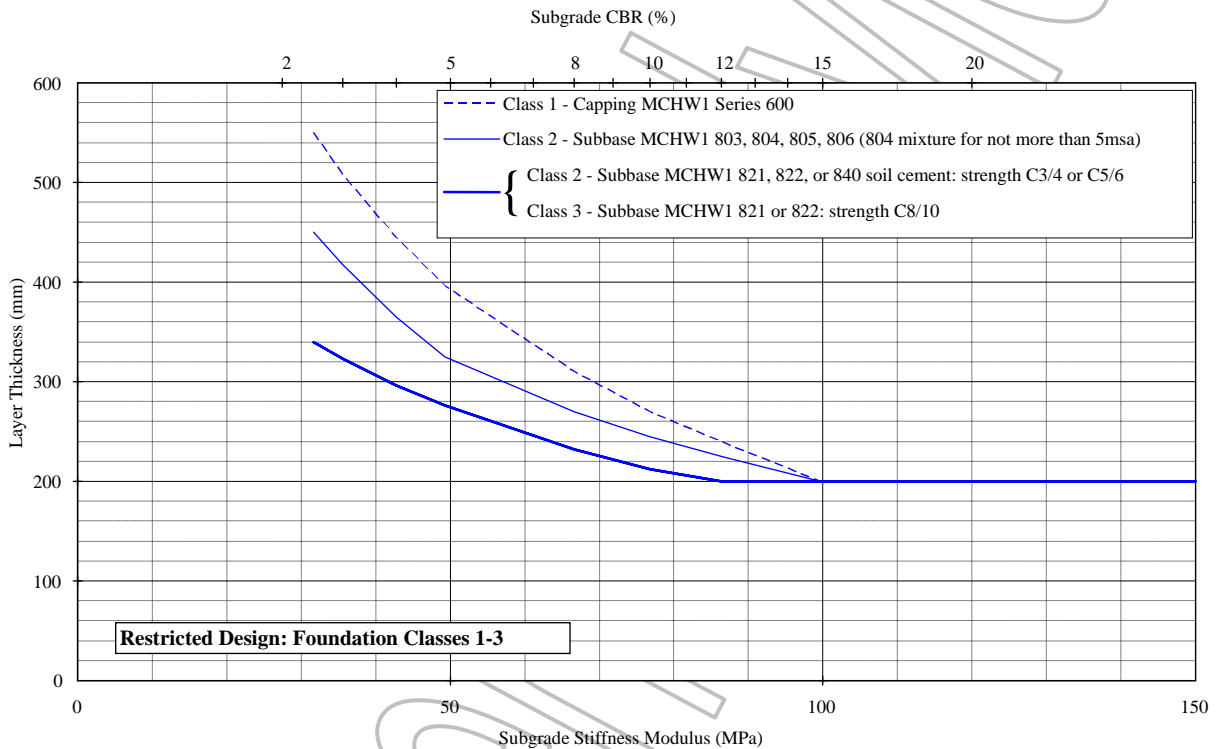

FIGURE 3.1 Restricted Design Options – Subbase or Capping only

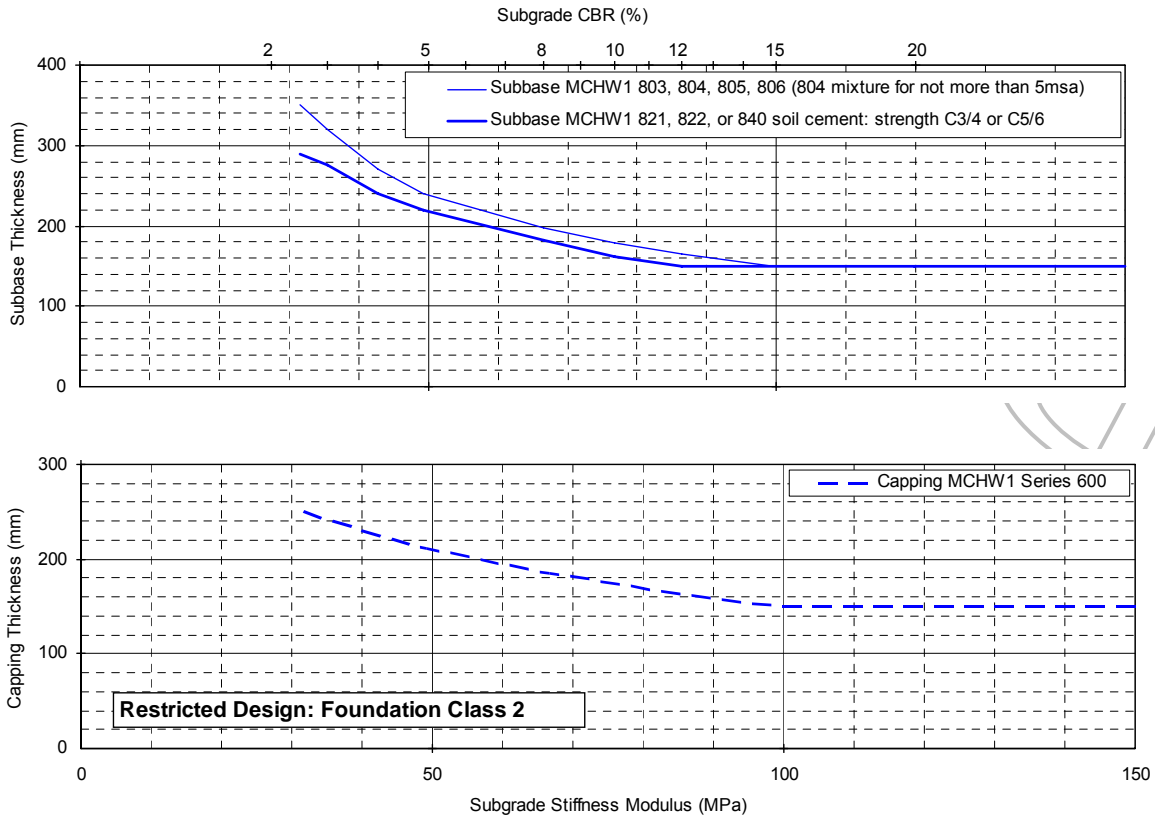

FIGURE 3.2 Restricted Design Options – Class 2 Subbase on Capping

Chapter 4. PERFORMANCE FOUNDATION DESIGNS

APPLICABILITY

- 4.1 The main objectives for developing Performance Designs for foundations and the Performance Related Specification for Foundations are:
- to facilitate the efficient use of a wide range of resources, incorporating natural, secondary and recycled materials as both binders and aggregates;
 - to provide some assurance that the material performance assumptions made during the design process are being, or are likely to be, achieved;
 - to recognise the structural contribution of improved foundation performance and hence permit the adjustment in thickness of the pavement layers above.
- 4.2 The philosophy of Performance Design relies on performance testing to confirm the physical properties that are critical to the design process. To ensure parity between different materials and minimise unnecessary exclusion, this evaluation is based on a common method of assessment.
- 4.3 The materials used in pavement foundations have a vast range of properties that affect performance (e.g. particle size, strength, elastic stiffness, stress dependency, curing rates). However, it is not practical to carry out testing for all of these properties and a single foundation surface modulus performance test provides a pragmatic solution.
- 4.4 Pavement foundation design in the UK has been based on the principles of layered linear elastic modelling since the 1980s (Powell et al, 1984). This approach requires the elastic stiffness of each foundation layer to be defined, enabling critical stresses and strains to be predicted. These are subsequently assessed against empirically derived limits, in order to reduce the risk of premature pavement failure to an acceptable level. The models have traditionally focused on a very restricted number of materials, with relatively well documented engineering properties.
- 4.5 Assessing the engineering properties of individual materials for both the construction and in-service situations is a complicated and lengthy process. It is simpler and more cost-effective to develop a single proxy measure, which can be used in all situations with all types of material, to predict the likely overall performance of the foundation.
- 4.6 The use of a Performance Related Specification for assessing Foundation Surface Modulus is compatible with the current UK methodology for pavement design, as described in HD26 (DMRB 7.2.3). This method requires a given level of Foundation Surface Modulus, referred to as a Foundation Class, to support various types of pavement construction and associated material thicknesses.
- 4.7 Performance Design is a method that can be used to predict the likely Foundation Surface Modulus that will be achieved by certain combinations of foundation layers over different types of natural ground (the subgrade). The basis for the model is described in more detail in Annex B.
- 4.8 The process for designing, constructing and testing a Performance Related Foundation is summarised in Figure 4.1.
- 4.9 Until publication of this standard in the Design Manual for Roads and Bridges, all Performance Foundation Designs will be subject to approval under a Departure from Standards.

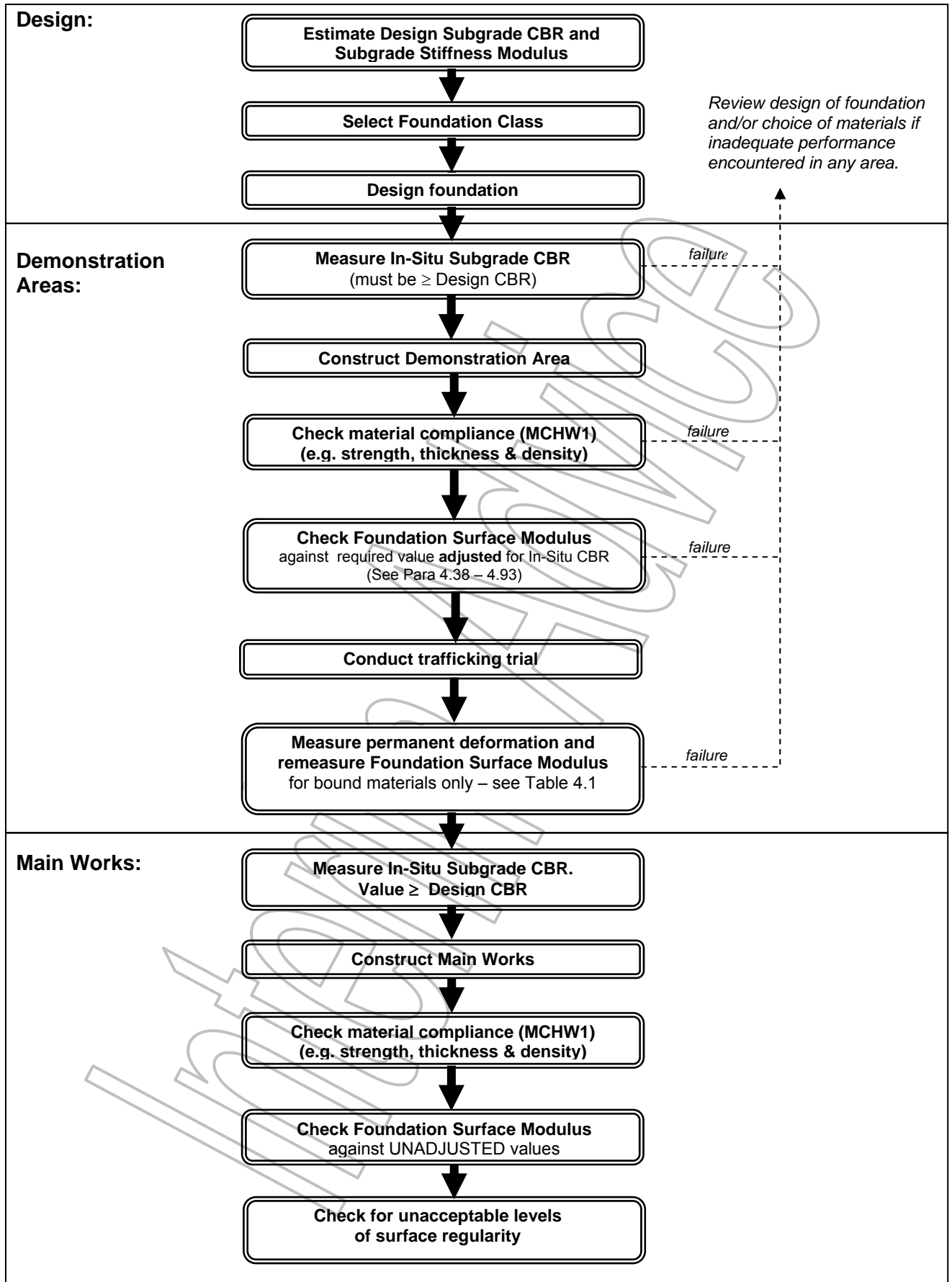

FIGURE 4.1 Summary Flowchart for Performance Related Foundations

- 4.10 Performance Foundation Design must only be used in conjunction with the Performance Related Specification for Foundations (Clauses 890 to 896), see Section 5.
- 4.11 The Performance Related Specification for Foundations requires a range of information to be collected during construction of the pavement foundation. The principal tests called for include those listed in Paragraph 3.4 and the measurement of the Foundation Surface Modulus at top of foundation level, throughout the Works (to be carried out immediately prior to construction of the overlying pavement layer).

SUBGRADE REQUIREMENTS

- 4.12 For design purposes, the Subgrade Surface Modulus must be estimated from CBR values using the procedure given in Chapter 5 (paragraphs 5.3 to 5.11). The Subgrade Surface Modulus used for design must be estimated using the lower value of the long-term and short-term CBR.
- 4.13 The Subgrade Surface Modulus for design and associated Design CBR must be stated by the Designer in Appendix 7/1 for each foundation area. These values must not be increased after construction has started.
- 4.14 Other methods for estimation of Design Subgrade Surface Modulus will be permitted with a Departure from Standards, provided that a satisfactory correlation with the reference method can be demonstrated.
- 4.15 The subgrade CBR value must be checked on site before foundation construction starts, in accordance with Clause 893 of the Specification (also see Paragraphs 5.12 to 5.15) and must be equal to, or be greater than, the Design CBR.
- 4.16 If the in-situ CBR is found to be less than the Design CBR, then the subgrade must either be improved to the Design CBR or the foundation redesigned.
- 4.17 Where the in-situ subgrade has an estimated CBR value less than 2.5 per cent, it must be improved as described in Chapter 5 (paragraphs 5.16 to 5.21) and its Design CBR must be based on the statements in those paragraphs

FOUNDATION SURFACE MODULUS REQUIREMENTS

- 4.18 Table 4.1 gives the unadjusted Mean Foundation Surface Modulus and Minimum Foundation Surface Modulus values, for each Foundation Class, and for different categories of materials, to be achieved or exceeded at the top of foundation level immediately prior to the construction of the overlying pavement layers.
- 4.19 Foundations may also be constructed using layers of different materials making composite foundations. Performance measures for these must be agreed as part of the Departure approval on a scheme specific basis.
- 4.20 Foundation Surface Modulus is measured using the Dynamic Plate Test (refer to Chapter 7) in accordance with Clauses 890, 891, 892 and 895 of the Specification.

		Surface Modulus (MPa)			
		Class 1	Class 2	Class 3	Class 4
Long-Term In-service Surface Modulus		≥50	≥100	≥200	≥400
Mean Foundation Surface Modulus	Unbound Mixture Types:	40 ✕	80 #	★	★
	Fast-setting Mixture Types:	50 ✕	100	300	600
	Slow-setting Mixture Types:	40 ✕	80	150	300
Minimum Foundation Surface Modulus	Unbound Mixture Types:	25 ✕	50 #	★	★
	Fast-setting Mixture Types:	25 ✕	50	150	300
	Slow-setting Mixture Types:	25 ✕	50	75	150

Table 4.1 Top of Foundation Surface Modulus Requirements

Note.

Fast-setting and slow-setting mixtures are defined in Paragraph 2.3

✕ *Only permitted on trunk roads including motorways that are designed for not more than 20msa*

Not permitted for pavements designed for 80msa or above (HD26 requirement)

★ *Unbound materials are unlikely to achieve the requirements for Class 3 & 4*

- 4.21 Dynamic Plate Test (DPT) devices for testing Surface Modulus, both Falling Weight Deflectometers (FWD) and Lightweight Deflectometers (LWD) must conform with the Specification Clause 895 and are also described in Chapter 7.
- 4.22 Where a LWD is proposed, a correlation exercise must be carried out in the Demonstration Area using the 25 measurement points (as specified in Clause 891 of the Specification). At each location, Foundation Surface Modulus must be measured using both the proposed LWD and the standard DPT device (an FWD) and the correlation procedure followed as defined in Specification Clause 895.
- 4.23 LWD devices may be used on a site specific basis to give an indication of likely compliance with the Performance Related Specification for Foundations. However, the standard DPT device (FWD) will constitute the reference method other than when the requirements of paragraphs 4.21 and 4.22 are satisfied.
- 4.24 The Mean Foundation Surface Modulus values have been chosen to provide assurance that the foundation is performing as expected in the **short term**, immediately before being covered by the overlying pavement layers. They are not expected to provide a direct method for predicting the long-term, in service, design Foundation Surface Modulus.
- 4.25 The Mean Foundation Surface Modulus is defined as the moving mean of five consecutive in-situ Foundation Surface Modulus measurements. The results are expected to contain significant scatter due to the inherent variability of the subgrade and the inconsistency of subbase and capping materials.
- 4.26 The Minimum Foundation Surface Modulus is defined as the value that must be exceeded by all individual measurements of in-situ Foundation Surface Modulus and it is intended to be the absolute threshold below which no part of an adequately constructed foundation is allowed to fall.

- 4.27 The Mixture Type referred to in Table 4.1 (Unbound, Fast-setting or Slow-setting – refer to Chapter 2, Paragraph 2.3) relates to the material used in the subbase layer and assumes that the same material is used throughout.
- 4.28 The Mean Foundation Surface Modulus requirement for Slow-setting Mixtures is lower than that for Fast-setting Mixtures, acknowledging that they may require a longer curing period before achieving their full Layer Modulus potential.
- 4.29 The Mean Foundation Surface Modulus requirement for Unbound Mixtures is lower than the expected long-term Modulus as it is measured in the partially confined condition (i.e. without the overlying pavement layers).
- 4.30 The Mean Foundation Surface Modulus requirement for Fast-setting Mixtures is higher than the expected long-term Modulus because they gain strength quickly, but can be expected to deteriorate during the life of the pavement.
- 4.31 It is considered unlikely that Unbound Mixture Types will economically achieve Foundation Classes 3 and 4, and Mean and Minimum Surface Modulus values have therefore not been included in Table 4.1. Approval may be sought if designers can justify specific material use for an individual scheme.
- 4.32 Experience of using Slow-setting Mixture Types is limited in the UK to date. Further background information on this topic can be found in TRL Report 408 (Atkinson, Chaddock and Dawson, 1999).
- 4.33 As further experience is gained using the Performance Related Specification for Foundations in the UK, it is anticipated that the values in Table 4.1 will be amended and the range of material specific values will be extended. The version in this Interim Advice Note reflects the generalised current state of knowledge.
- 4.34 A separate Departure from Standards may be sought for all Foundation Classes to agree alternative Mean and Minimum Foundation Surface Modulus values where sufficient additional data is available to demonstrate satisfactory performance.
- 4.35 Materials complying with Clause 840 of the Specification (Treated Soils) are not currently permitted in Foundation Class 4, without a separate Departure from Standards approval.

Demonstration Areas

- 4.36 Demonstration Areas are required to enable the adequacy of the performance of each foundation design to be assessed. It also allows material production and laying procedures to be proved, prior to construction of the Main Works.
- 4.37 Generally, the Demonstration Area should be situated where the in-situ subgrade CBR is equal to the Design CBR. However, where this is not possible (e.g. due to drying of clay subgrades in hot summers), it is only permitted for the in-situ subgrade CBR in the Demonstration Area to be **greater** than the Design CBR. Where the in-situ CBR is lower than the Design CBR, a new foundation design is required, as this demonstrates that the designer has not correctly estimated the lower value of the short-term and long-term CBR.

- 4.38 The Mean and Minimum Foundation Surface Modulus values given in Table 4.1 must be adjusted (in the Demonstration Area only, see paragraph 4.39) if the in-situ CBR is greater than the Design CBR. High in-situ CBR values are likely to give unrealistically elevated Foundation Surface Modulus values, which will subsequently decrease when the subgrade weakens through moisture ingress.
- 4.39 For the demonstration area, the appropriate values selected from Table 4.1 to be achieved or exceeded must be adjusted using the following equation:

$$E_{\text{adjusted}} = E \times (1 + (0.28 \times \ln (\text{CBR}_{\text{in-situ}}/\text{CBR}_{\text{design}})))$$

Where: E_{adjusted} is the adjusted Foundation Surface Modulus value (either mean or minimum)

E is the Mean or Minimum Foundation Surface Modulus value taken from Table 4.1

$\text{CBR}_{\text{in-situ}}$ is the actual in-situ CBR in the Demonstration Area
 $\text{CBR}_{\text{design}}$ is the Design CBR

Design Example 2

Design CBR estimated at 3% (Paragraph 5.3)

Design carried out for Foundation Class 3 – 200MPa

From Table 4/1:

Design Mean Surface Modulus (Fast-setting Mixture) = 300MPa

Design Minimum Surface Modulus (Fast-setting Mixture) = 150MPa

Adjusted Values for two possible In-situ CBR values are:

In-situ CBR	Adjusted Mean	Adjusted Minimum
5%	343 MPa	171 MPa
7%	371 MPa	185 MPa

- 4.40 It is recommended that after laying, the Surface Modulus testing is not carried out at ages less than 24 hours in the case of Unbound Mixtures and 7 days in the case of Fast-setting Mixtures. For Slow-setting Mixtures, it is recommended that the testing be carried out after the same amount of time for which the foundation is likely to remain exposed during the main works. If site arrangements require that a foundation will remain uncovered for a longer or shorter time, then alternative arrangements for testing the demonstration area may be necessary.
- 4.41 It may be advisable to undertake Surface Modulus measurements at the surface of intermediate foundation layers, as this may provide useful information in the event of inadequate performance at top of foundation level. The designer should provide details of the modulus values that should be achieved.

- 4.42 A trafficking trial is required for each Demonstration Area at top of foundation level, as specified in Clause 891. This requires:
- a limit on rut depth, depending on foundation thickness and Mixture Type, and
 - the Foundation Surface Modulus values continue to meet the Mean and Minimum Surface Modulus requirements after trafficking (Fast-setting and Slow-setting Mixtures only).

Main Works

- 4.43 Performance testing is to be carried out on the main works as required by the Specification. The value of Foundation Surface Modulus set out in Table 4.1 for the main works is to be achieved not more than 24 hours before being covered by pavement layers. No adjustment for in-situ CBR is required, as the adequacy of the design has already been shown in the Demonstration Area.
- 4.44 For schemes where the foundation is to remain exposed for a long period, an earlier check is advised to give assurance that the Foundation Surface Modulus requirements will be achieved. Further checks are likely to be necessary, where foundations are trafficked before being overlaid.
- 4.45 The Overseeing Organisation may permit the contractor to continue foundation construction without a requirement to achieve the Foundation Surface Modulus values set out in Table 4.1 provided that other criteria were to be consistently achieved. Proposals for an alternative procedure that will still demonstrate that the constructed foundation meets the performance criteria should be included as part of the Departure application. Foundation Surface Modulus values would still need to be monitored for recording purposes only.
- 4.46 Material testing, density and thickness measurement in accordance with the relevant clauses of Specification Series 600 and 800 (including Clauses 890 to 896 are required throughout the main works to demonstrate compliance.

THICKNESS DESIGN

- 4.47 The layer thicknesses derived using the Performance Foundation Design Method are based on the consideration of three criteria (Chaddock and Roberts, 2006):
- Protection of the subgrade during construction;
 - Provision of adequate support stiffness to the overlying pavement layers;
 - Practical minimum layer thicknesses for construction.
- 4.48 There are a large number of possible designs for the various combinations of Subgrade Surface Modulus and foundation material, in order to achieve the desired Foundation Class. Some example design charts are shown in Figures 4.2 to 4.6. Interpolation between the lines can be used to develop designs with alternative Layer Modulus values. Equations for these example designs have been provided in Annex A. A method of generating alternative designs by modelling, not covered by the examples in Figures 4.2 to 4.6, is discussed in Annex B. The use of granular subbase to Clause 804 (Type 2) should not be used for any pavement design for more than 5msa.

- 4.49 Experience has demonstrated that foundations constructed on subgrades with a Design CBR of less than 2.5 per cent may cause problems and designs for subgrades below these values are not given. See Paragraph 4.17
- 4.50 The practical minimum foundation thicknesses have been taken as 150mm for all materials in a Class 1 or 2 foundation, 175mm for materials in a Class 3 Foundation and 200mm for materials in a Class 4 Foundation. The increase in minimum thicknesses for Classes 3 and 4 relates to their proportional sensitivity to variations in thickness. Thin layers of stiffer bound materials are also more susceptible to cracking and it is important that these materials do not crack beyond the levels assumed in the design.
- 4.51 Maximum permissible Layer Stiffness values have also been imposed for each Foundation Class to minimise the risk of selecting very thin, very stiff foundation layers at lower subgrade CBR values. The maximum permissible Layer Stiffnesses to be used in design are:

Foundation Class 1	100 MPa
Foundation Class 2	350 MPa
Foundation Class 3	1000 MPa
Foundation Class 4	3500 MPa

These maximum stiffness values apply whatever method is used to design the foundation.

- 4.52 Examples of designs with subbase on capping are only presented in this Chapter for Foundation Class 2. The structural contribution of capping materials with low Layer Stiffness values is limited when compared with the stiffness of subbase materials required to achieve Foundation Classes 3 and 4. Their inclusion in the design model does not, therefore, demonstrate a significant reduction in the thickness of subbase required but designers should consider the practical advantages of including capping materials in the foundation design. More information is available in TRL Report PPR127 (Chaddock & Roberts 2006).
- 4.53 The inclusion of a capping layer however, should always be considered for the practical benefits they afford, enabling construction plant to lay the subbase and providing a good base for the necessary compaction to be achieved. The provision of a capping layer may be particularly appropriate for lower strength subgrades and can, if the material is suitable, also provide a drainage path below a layer of bound material.
- 4.54 The thicknesses determined using the examples in this Chapter are the minimum thickness requirements to achieve the design assumptions. Permitting construction using normal level tolerances (as specified in Clause 702 of the Specification) is likely to result in an as-built foundation that is significantly thinner than assumed in the design. This, in turn, will lead to a significant risk that the Mean and Minimum Foundation Surface Modulus Values will not be achieved. For this reason, it is essential that the designer either specifies a permitted negative tolerance of zero or increases the design thickness by an appropriate amount (possibly 15mm) if retaining the requirements of Clause 702 of the Specification.
- 4.55 It is recommended that design thicknesses are rounded upwards to the nearest 10mm.

4.56 The completed surface of all foundations must meet all other relevant criteria in Series 700 of the Specification.

Design Example 3

Subgrade Surface Modulus for design estimated as 35MPa (approximately 3% CBR)
Options covered by Figures 4.2-4.6 (minimum thicknesses, tolerances to be added and then rounded up):

- Foundation Class 1** (Capping only; Figure 4.2):
 - 460mm of 50MPa material
- Foundation Class 2** (Subbase only; Figure 4.3):
 - 290mm of 200MPa material
- Foundation Class 2** (Subbase on 75MPa capping; Figure 4.6):
 - 150mm of 350MPa material + 240mm capping (75MPa)
- Foundation Class 3** (Subbase only; Figure 4.4):
 - 215mm of 1000MPa material
- Foundation Class 4** (Subbase only; Figure 4.5):
 - 435mm of 1000MPa material

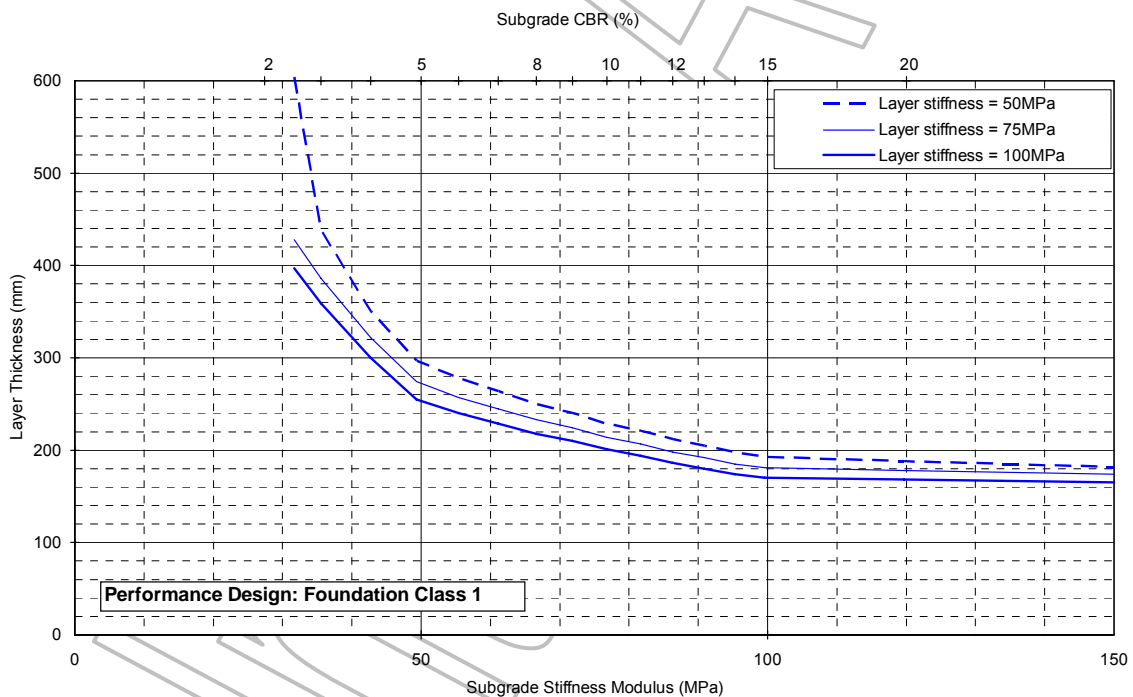

FIGURE 4.2 Class 1 Designs – Single Foundation Layer

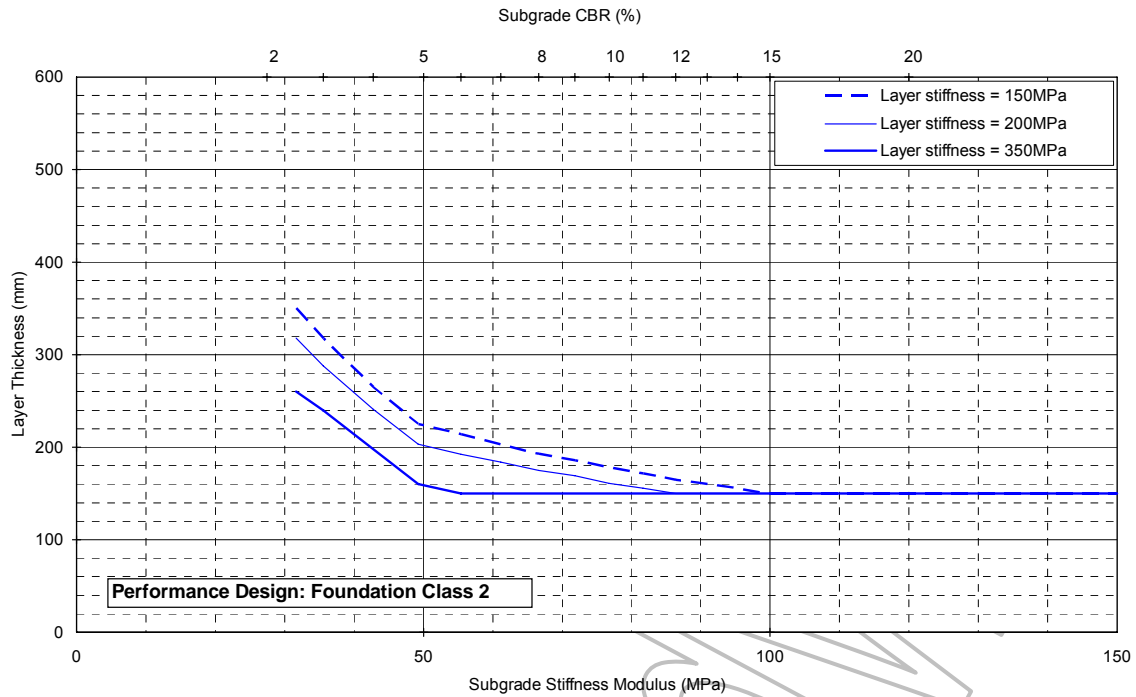

FIGURE 4.3 Class 2 Designs – Single Foundation Layer

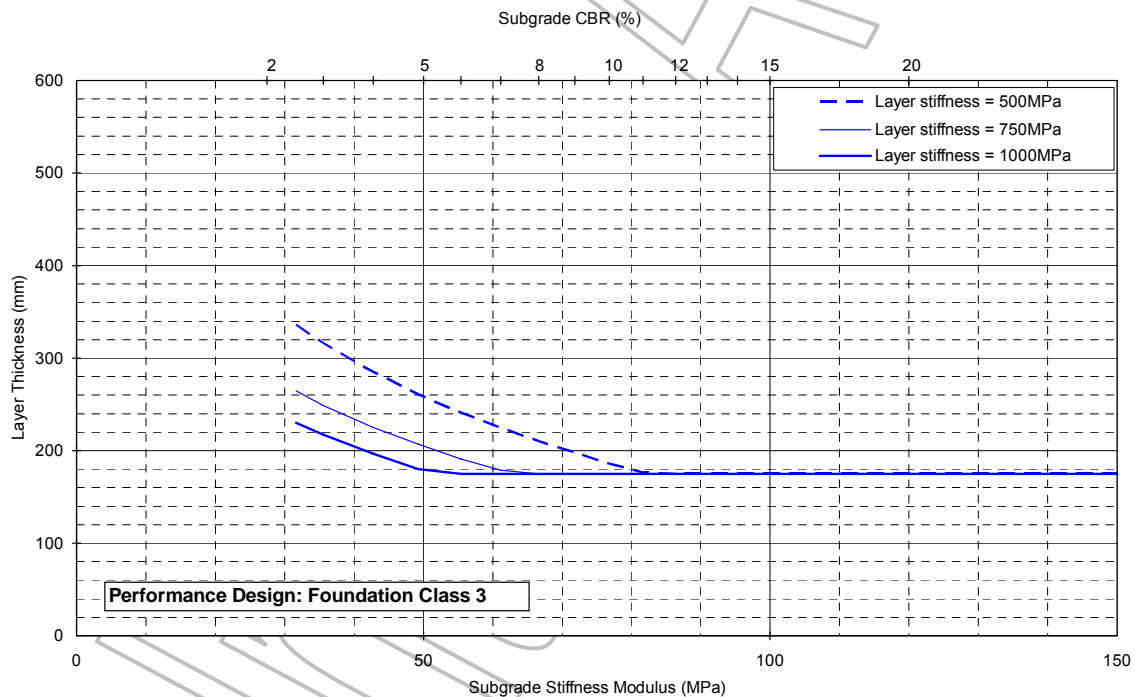

FIGURE 4.4 Class 3 Designs – Single Foundation Layer

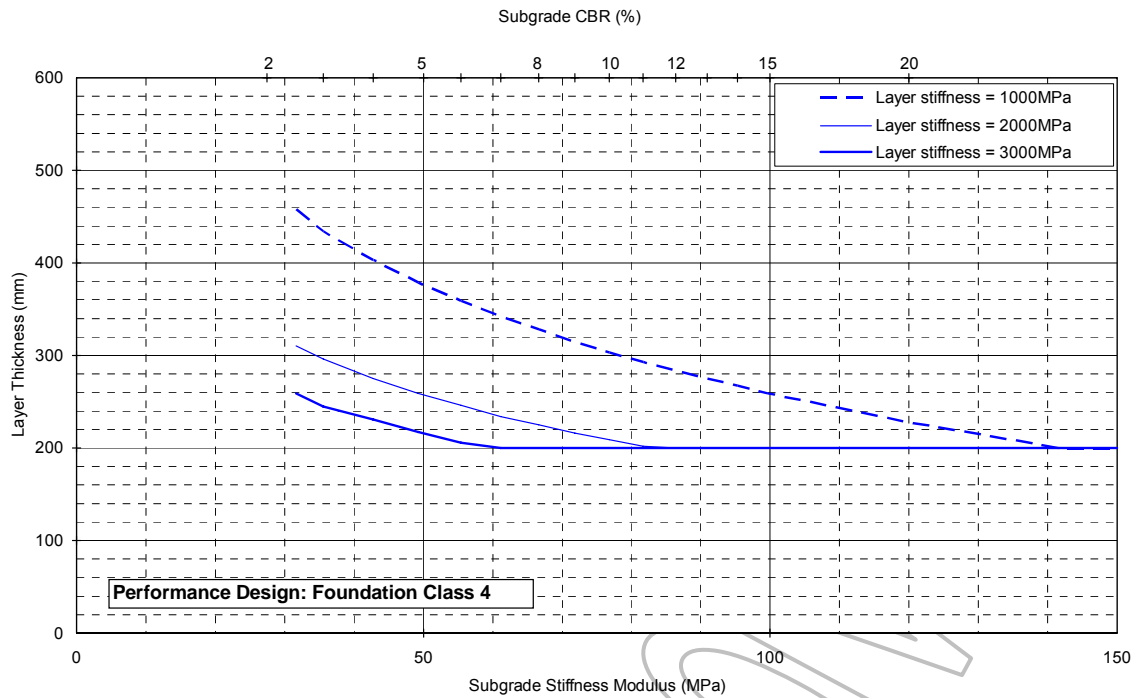

FIGURE 4.5 Class 4 Designs – Single Foundation Layer

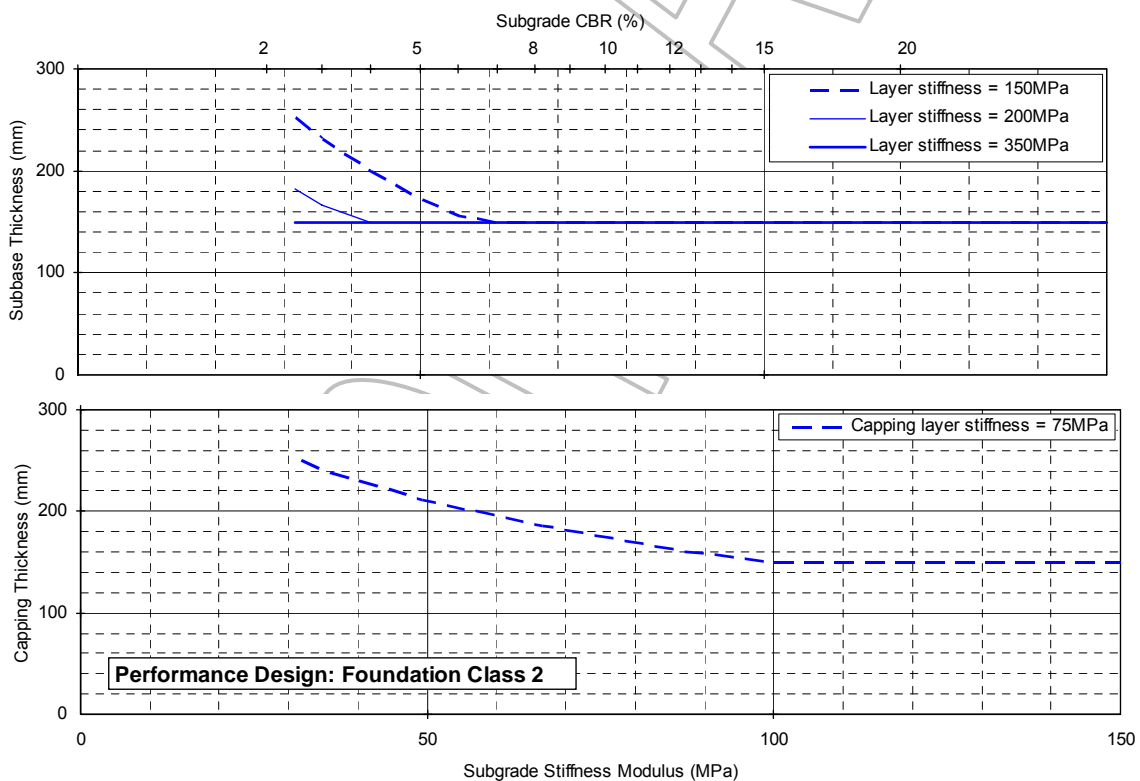

FIGURE 4.6 Class 2 Designs – Subbase on Capping

Chapter 5. CHARACTERISATION OF MATERIALS

SUBGRADE

Design Phase

- 5.1 In the UK, the primary material performance characteristic used in foundation design is Stiffness Modulus. For subgrades, this property is difficult to measure reliably and consistently, so historically California Bearing Ratio (CBR) has been used as an indirect measure.
- 5.2 Full access to the construction site is not always possible during the design phase so it can be difficult to carry out in-situ testing. Where a Geotechnical Investigation is carried out, representative samples should be taken of the subgrade materials likely to be encountered on site.
- 5.3 Estimation of the likely long-term, short-term and hence Design CBR should be derived using laboratory CBR tests in accordance with BS 1377 Pt 4 (1990). Further advice is given in HA44 (DMRB 4.1.1) and in Paragraph 7.6. The Design CBR is the lower of the long-term and short-term CBR.
- 5.4 Laboratory testing has the advantage that realistic conditions of moisture and 'disturbance' can be simulated. The tests should be carried out over a range of conditions to reproduce, as far as possible, the conditions of moisture content and density which are likely to be experienced during construction and in the completed pavement. Cohesive soils should be compacted to not less than 5% air voids to reproduce the likely conditions on site. Equilibrium moisture content can be deduced from measurements on a suction plate (Black and Lister, 1979).
- 5.5 Where it is not possible to collect material samples for assessment using the laboratory CBR tests, the Suction Index Method should be used, as described in Appendix C of LR1132 (Powell, Potter, Mayhew and Nunn, 1984). Table 5.1 gives an extract from Table C1 in LR 1132 with estimated values for long-term CBR depending on soil type particularly for clay subgrades where moisture and plasticity index are significant issues. These CBR values assume a high water table and that the foundations may be wetted by ground water during their life. Further advice related to soils criteria are given in Figs C2 and C3 in LR 1132.

SOIL	PI %	Thin	Thick
		Estimated CBR %	
Heavy Clay	70	2	2
	60	2	2
	50	2	2.5
	40	2.5	3
	30	3	4
Silty Clay	20	4	5
Sandy Clay	10	3	6
Silt*	-	1	1
Sand (poorly graded)	-	20	
Sand (well graded)	-	40	
Sandy Gravel (well graded)	-	60	
* estimated assuming some probability of material saturating			
Notes 1) A thick layered construction is a depth to subgrade of 1200mm 2) A thin layered construction is a depth to subgrade of 300mm			

Table 5.1 Equilibrium Subgrade CBR Estimation

- 5.6 Where a scheme is large enough that it may include several different soil types or moisture conditions, a more extensive survey will be necessary. The survey will consider the availability of materials and will ensure that all variations in subgrade are recorded and special emphasis can be made at transition zones and cut/fill interfaces.
- 5.7 In selecting the Design CBR value for the subgrade, consideration must be given to the likely moisture conditions applying during construction, assuming that appropriate precautions are taken against excessive disturbance, as demanded by the Specification.
- 5.8 The designer must also consider the likely long-term equilibrium moisture condition, making reasonable allowance for moisture ingress through the pavement, but assuming drainage is correctly installed as designed. Testing of moisture content beneath adjacent existing roads may provide useful information.
- 5.9 For imported fill soils, the stiffness of the subgrade must be assured in the long term, which requires adequate compaction to ensure that it has a high density and low air voids content. The Moisture Condition Value (MCV – Matheson and Winter, 1997) is normally used to help ensure acceptable compaction and MCV testing is usually carried out at both the design stage, to evaluate the materials available, and at the construction stage, to ensure that soils are placed in an acceptable moisture condition. This process should ensure the long-term moisture equilibrium of the subgrade by minimising moisture ingress. In this manner, the subgrade should provide a stable platform for the pavement throughout its design life. The MCV can also be related to the ability of a subgrade to withstand construction traffic. There are a number of correlations between MCV and soil strength which, though to some extent material specific, may provide useful information for preliminary design purposes (Lindh and Winter, 2003; Winter, 2004). The MCV test is described in Clause 632 of the Specification (MCHW 1).

- 5.10 Other methods for estimating the design CBR will be permitted with Departure from Standards approval, provided that evidence of both suitability and reliability can be demonstrated. For coarser materials, the plate bearing test may also be appropriate, more information is available in Section 7.
- 5.11 For Performance Design, the Design CBR must be converted to the Subgrade Surface Modulus. The following equation has been derived from work on certain soils (Powell et al, 1984) and this must be used unless separate Departure from Standards approval has been given:

$$E = 17.6 (\text{CBR})^{0.64} \text{ MPa}$$

Where CBR is given as a % value.

Construction Phase

- 5.12 During construction, the in-situ CBR must be checked against the Design CBR, for both Restricted and Performance Designs.
- 5.13 The Dynamic Cone Penetrometer (DCP) method must be used to measure the in-situ subgrade strength, as described in Clause 893 of the Draft Specification. Not less than 5 tests are to be carried out in the Demonstration Area and at not more than at 60m intervals for the Main works as required by the Specification. Additional tests may be necessary to identify the location of different subgrade conditions.
- 5.14 The results from the DCP testing must be converted to CBR using the procedure described in Clause 893 of the Draft Specification.
- 5.15 Other methods for measurement of in-situ CBR will be permitted with separate Departure from Standards approval, provided that a satisfactory correlation with the Clause 893 reference method can be demonstrated.

Subgrade with low CBR (CBR < 2.5%)

- 5.16 The minimum permitted Design CBR is 2.5% CBR. Where a subgrade has a lower CBR it is considered unsuitable support for a pavement foundation. It must therefore be permanently improved using one of the options given in the following paragraphs.
- 5.17 The material at the surface can be removed and replaced by a more suitable material. If the depth of relatively soft material is small, it can be replaced in its entirety, although it may only be necessary to replace the top layer. The thickness removed will typically be between 0.5 and 1.0m.
- 5.18 Although the new material may be of better quality, the new Design CBR should be assumed to be equivalent to 2.5%, in order to allow for effects of any softer underlying material and the potential reduction in the strength of the replacement material to its long-term CBR value.
- 5.19 If the soil is cohesive, a lime (or similar) treatment may be appropriate, subject to soil suitability being demonstrated. Details of various soil treatments are given in HA44 (DMRB 4.1.1). The new Design CBR should again be assumed to be equivalent to 2.5% unless agreed otherwise under Departure from Standard approval. HA 74 (DMRB 4.1.6) contains further advice on stabilisation.

- 5.20 For certain conditions, the incorporation of a geosynthetic material into the foundation design may be advantageous. Approval under a Departure from Standard to adopt an alternative Design CBR value will be necessary, based on testing or previous experience with the specific geosynthetic and the materials being used on the scheme.
- 5.21 If the soil is reasonably permeable, a deeper than normal drainage system may be considered, together with a system of monitoring the improvement expected. Design of the main foundation may then be based on the conditions are achievable in the time available subject to consideration of the long-term equivalent CBR value.

CAPPING AND SUBBASE

- 5.22 In order to make use of the Performance Designs in Chapter 4 it is necessary to estimate the long-term Layer Modulus values for the materials in each proposed foundation layer. Some of the techniques that may be suitable to assessing the Element Modulus of foundation materials are listed in Table 5.2.

Test Method	Suitable for:	Information in:
Dynamic Plate Testing of compacted trial layers	Unbound, Fast-setting and Slow-setting	Specification Clause 895
Modulus of Elasticity testing in compression	Fast-setting and Slow-setting Mixtures	BS EN 13286-43:2003
Triaxial testing	Unbound Mixtures	BS EN 13286-7: 2004
Springbox testing of laboratory specimens	Unbound Mixtures	Chapter 7

Table 5.2 Applicability of Stiffness Modulus Test Techniques

- 5.23 Estimates of Layer Modulus derived using the techniques given in Table 5.2 are not necessarily directly comparable. This is due to variability in the test conditions (e.g. confining stress and sample size).
- 5.24 Use of the Dynamic Plate Test (DPT) on compacted trial layers has the advantage that the same test is called up for compliance assessment by the Performance Related Specification for Foundations. The test can be carried out either on a small trial site or in a suitably sized (minimum 1m square and 0.5m deep) container in the laboratory. The advantage is that the material can be compacted in a realistic manner. However, the modulus will be a partially confined value, which for unbound materials can be approximately 60% of that expected when confined beneath a finished pavement. Furthermore, in the laboratory, the results will be affected by the substrate upon which the layer is compacted and due to the size of specimen, testing is usually restricted to an LWT.
- 5.25 The standard laboratory test for Modulus of Elasticity of HBM mixtures is the Compression Test, one of three described in BS EN 13286-43. It is appropriate for those materials which have sufficient strength to remain intact during the test. However, the resulting Stiffness Modulus is that applying to a small intact and very well compacted specimen of material, whereas the condition in-situ may be less dense and is likely to include significant cracking due to shrinkage and temperature fluctuation. For these reasons, no more than 20% of the measured laboratory

Stiffness Modulus may be taken for long-term design in the case of Fast-setting Mixtures. For Slow-setting Mixtures, no more than 10% of the laboratory value should be used. If well-documented evidence demonstrates that other values can be justified then, in such circumstances, Departure from Standards approval will be required to use the alternative. These values assume that no abnormal damage is caused to the material during construction.

- 5.26 Designers should be aware that because materials vary and also site practice and conditions can alter, the long-term, in-situ design Layer Stiffness Modulus of an HBM, derived from laboratory stiffness testing using the factors described in the previous paragraph, may not always meet the Surface Modulus requirements of the Performance Related Specification (see Chapter 4) when site testing is carried out.
- 5.27 Springbox testing (See Chapter 7) has the advantage that it allows a small sample of unbound material to be tested under approximately realistic stress conditions and under appropriate (normally soaked then drained) moisture conditions.
- 5.28 Stiffness Modulus varies according to the applied stress conditions and for unbound materials also varies according to the moisture state of the material.
- 5.29 An unbound material which is confined by overlying pavement layers will often appear stiffer than the same material when uncovered and therefore partially unconfined. This means that the Stiffness Modulus apparent during construction will tend to be lower than the Stiffness Modulus expected in service. This is reflected in Table 4.1 for the top of Foundation Surface Modulus requirements.
- 5.30 An unbound material at high moisture content can appear significantly less stiff than a drier material. This means that the Stiffness Modulus apparent during construction can be significantly affected by the weather conditions applying at the time and the effectiveness of the drainage system, and often may not reflect the longer term in-service condition (at equilibrium moisture content).
- 5.31 Since a 'cracked' state is assumed for the in-service condition of hydraulically bound mixtures (HBMs), the initial 'uncracked' or 'less cracked' material at the time of construction may have a higher Stiffness Modulus.
- 5.32 Some of the HBMs permitted by the Specification are relatively slow setting. This means that the Stiffness Modulus apparent during construction will be significantly less than that achievable in the longer term. Also, such materials are susceptible to damage, particularly by trafficking, both during construction and early in their service life, which may result in their expected long-term Stiffness Modulus being reduced.
- 5.33 Dynamic Plate Tests on existing pavements can be used to derive Foundation Surface Modulus values and are applicable in major reconstruction or widening schemes where an existing foundation layer is to be retained in the rehabilitated pavement. The technique known as back-analysis (see HD29, DMRB 7.3.2) will allow derivation of a Foundation Surface Modulus, and it will neither be practical nor necessary to distinguish the Stiffness Moduli of individual foundation layers. For Dynamic Plate Testing of existing pavement foundations refer to HD29 (DMRB 7.3.2).

Chapter 6. DRAINAGE AND FROST

Drainage

- 6.1 It is of vital importance to keep water out of the subbase, capping and subgrade, both during construction and during the service life of the pavement.
- 6.2 It is good practice and will reduce the opportunity for foundation deterioration if the carriageway drainage is constructed and kept operational before foundations are constructed.
- 6.3 During construction every effort should be made to protect the subgrade by constructing and protecting foundation layers before rain can soften it. The Performance Related Specification for Foundations provides a means of quantifying whether the actions, or omissions, of the contractor have contributed to the degradation of the foundation. Installing deep subgrade drains and sloping the formation to shed water could also prevent problems due to excess water not only during construction but also in the completed pavement.
- 6.4 In the long term, infiltration of water through the pavement should be minimised by good design, construction and maintenance. An escape route for water that succeeds in entering the foundation should always be provided (Figure 6.1).
- 6.5 Wherever possible, the foundation drainage should be kept separate from pavement run-off drainage in all new construction and in reconstruction work. There should always be a down-slope route from the subbase to the drain. Further details are given in HA44 (DMRB 4.1.1).
- 6.6 In reconstruction and widening projects it is necessary to maintain the continuity of drainage from existing capping and subbase materials through adjacent new materials to a drain, using appropriate thicknesses and crossfalls. Where strict adherence to the designs in Chapters 3 and 4 would introduce a barrier to such drainage, a Departure from Standards should be sought and an alternative foundation design proposed. This may include use of permeable bound materials or weep-pipes, and may, exceptionally, involve departure from the pavement materials and thicknesses derived from HD26/06.

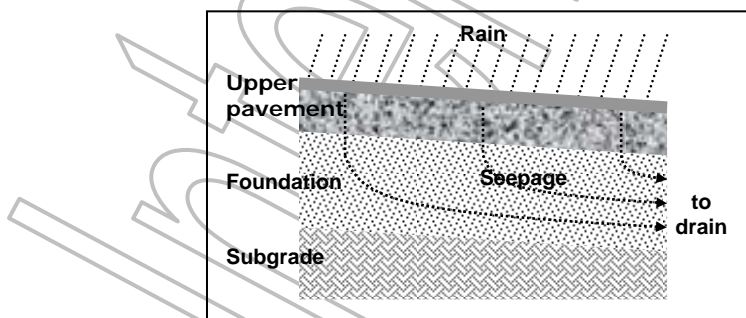

FIGURE 6.1 Foundation Drainage

- 6.7 A granular aggregate drainage blanket (MCHW 1 Series 600) of thickness at least 150mm and not more than 220mm may be used to drain water that infiltrates through the pavement. In order to stop pore clogging by fines from other adjacent layers, geosynthetic separators may be used when those layers are constructed of fine soil or fine capping. A drainage layer of this type may be particularly appropriate below a

bound foundation layer. The drainage layers so formed may be treated as capping for structural design purposes.

- 6.8 When the water table is high and especially when the subgrade is moisture sensitive with a Plasticity Index < 25 , slot drains as detailed in the Highway Construction Details, can be beneficial. The drain is placed below the bottom of capping (or subbase if no capping is used), to drain any water that may permeate through these materials. Deeper drains can be beneficial in drying and strengthening these, and some other soil types.
- 6.9 It is useful to check the speed at which water can drain out of a granular subbase as a result of ingress due, perhaps, to a cracked or damaged pavement or a surcharging drain. A procedure for calculating this is given in Jones and Jones (1989a) along with a means of estimating ingress through cracks in the bound layers. On this basis it may be possible to specify a permeability value. Care should be taken to ensure that the value required does not conflict with any limitations imposed by a specified grading, see Jones and Jones (1989b).
- 6.10 If it is necessary to determine the permeability of the subbase or capping material, this must be done on the full grading, at the correct density under a low hydraulic head. A suitable permeameter and procedure is described in HA41 (DMRB 4.2.4)
- 6.11 Drainage of the subbase may be omitted only if the underlying materials (capping, subgrade) are more permeable than the subbase, and the water table never approaches the underside of foundation closer than 300mm.

Frost Protection

- 6.12 For routine cases all material within 450mm of the road surface shall be non frost-susceptible as required by the Specification Series 600 and tested according to BS812: Part 124 (1989).
- 6.13 This requirement can be over-severe in some places (e.g. coastal areas) and may be reduced to 350mm if the Mean Annual Frost Index (MAFI) of the site is less than 50. Advice on the frost index for any particular area may be obtained from the Met Office and further information from TRL Report RR45 (1986).
- 6.14 The frost index is defined as the product of the number of days of continuous freezing and the average amount of frost (in degrees Celsius) on those days.

Chapter 7 TESTING

- 7.1 The two reasons for testing pavement foundation layers are to check compliance with the Specification during construction and in pavement assessment. Also see HD30 (DMRB 7.3.3). This chapter introduces different test devices. It is for general information and advice only and does not comprise part of the Overseeing Organisation's requirements although some tests are included in the Performance Related Specification for Foundations, (Draft Clauses 890 to 896).

Density Testing (Figure 7.1)

- 7.2 Tests on density can be carried out using a nuclear density gauge. A radiating source is applied to the material. The amount of radiation detected decreases in proportion to the bulk density of the material between source and receiver. To determine the moisture content another source sends out radiation intercepted by hydrogen atoms in the test material. The dry density is calculated from the bulk density and the moisture content. If the material being tested is carbonaceous, care is required in interpreting the moisture content and dry density obtained. Testing is extremely rapid (less than 5 minutes) and a reading may be repeated readily. The machine is portable. Calibration is required for each soil or aggregate that is to be tested.

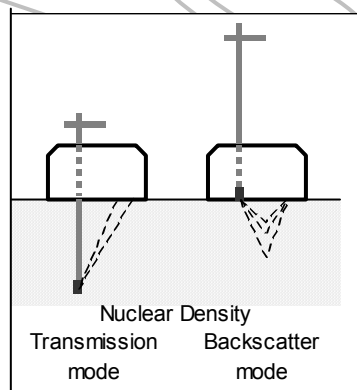

Figure 7.1 Density Testing Apparatus

- 7.3 It should be noted that two modes of nuclear density testing are possible. The quickest and easiest is 'backscatter' mode, which is influenced only by the density of the top 100-150mm of material and is most heavily influenced by material very near the surface. 'Transmission' mode should generally be used for all testing of foundations. Regulations related to security as well as to health and safety must be followed.
- 7.4 The volumetric test involves excavating and weighing material removed from a small hole and refilling with uniform sand. The test is time-consuming but can give a direct means of measuring density for comparison with laboratory values. Other non-nuclear means of measuring density using electronic methods are available but may not meet the depth requirement for measuring foundations.

California Bearing Ratio

- 7.5 The California Bearing Ratio (CBR) test involves the insertion of a 50mm diameter plunger into the ground surface at a rate of 1mm per minute, whilst the load is recorded. Surcharge rings can be placed around the plunger to simulate an

overburden. A laboratory version of the same test is available in which the sample tested is constrained within a 152.5mm diameter mould. The load at penetrations of 2.5 and 5mm is compared with the result for a standard aggregate and the ratio given as a percentage. The test is not suitable for coarse aggregates because the plunger and aggregate particles will be of similar size. The test measures neither Stiffness Modulus nor Shear Strength directly – giving a somewhat combined measure of both. It takes around half an hour on site and between 1 and 2 hours in the laboratory and there is a large body of experience of its use.

- 7.6 There are several variants on the CBR test; laboratory, field, with surcharge, saturated etc. In the context of this document the laboratory CBR with a surcharge to simulate the appropriate vertical overburden stress of the case being considered should be taken as the standard method used. The appropriate moisture content and wetting or drying condition is also important. Laboratory CBR results for granular soils are often higher than those in the field due to mould confinement effects. The test is penetration controlled and so does not model the stress level imposed by traffic. CBR is an empirical test and is best measured as initially intended although other test devices such as the cone penetrometer, the Dynamic Cone Penetrometer and the Plate Bearing Test can be used to determine approximate estimates of CBR.

Dynamic Cone Penetrometer

- 7.7 Various sizes of static field cone penetrometer for insertion into a test material exist for the rapid approximate assessment of CBR. In general they only cover a fairly low CBR range and are therefore applicable to soft and medium fine grained subgrades.
- 7.8 The Dynamic Cone Penetrometer (DCP – Figure 7.2) is similar to other field cone penetrometers except that it is driven into the ground under the action of a weight dropped onto an anvil. It is therefore suited to stronger and coarser materials than other penetrometers. The rate of penetration into the ground can then be related approximately to CBR. The standard equipment and its interpretation are discussed in more detail in HD 29 (DMRB 7.3.2)
- 7.9 The Dynamic Cone Penetrometer is a device incorporating an 8kg steel drop weight that falls vertically through 575mm and makes contact with a relatively light steel anvil. The anvil is rigidly attached, via steel rods to a 20mm diameter 60° steel cone, which is thus driven vertically into the ground. Requirements are included in the Specification Clause 893.



FIGURE 7.2 The Dynamic Cone Penetrometer

- 7.10 Exceptionally, other dynamic cone equipment may be used providing it has been calibrated against equipment meeting the requirements of the Specification for the type of materials present.

Test Procedure

- 7.11 For subgrade assessment the result for each test are recorded as the distance in millimetres per blow between 50mm and 550mm of penetration from top of subgrade level. The procedure for calculation of material strength is given in the Specification and is based on a relationship established by TRL for medium to fine grained soils.

Usage

- 7.12 The Dynamic Cone Penetrometer may also be used through many other materials, particularly in a composite foundation, to measure both their CBRs and layer thicknesses. However, this strength measure will not normally be specified for materials overlying the subgrade since results are highly dependent on particle size and can therefore, without calibration to specific materials, be misleading. The DCP can be a useful additional measure for assessment of the Demonstration Areas, and is particularly valuable for evaluating the properties of an existing pavement foundation.

Plate Bearing Test (Figure 7.3)

- 7.13 For coarser materials the Plate Bearing Test may be found appropriate for determination of subgrade CBR values. The test is described in detail in BS1377 (1990) and involves placing a circular plate on a foundation layer. Its use for testing is described in the MCHW 1 Series 600. For use on pavement foundation materials, there is no need for removal of surface material or for non-vibratory compaction.

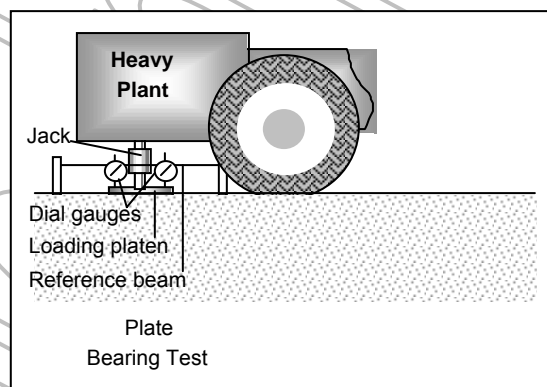

Figure 7.3 Plate Bearing Test

- 7.14 An approximate empirical relationship with CBR can be made as follows:

$$\text{CBR} = 6.1 \times 10^{-8} \times (k_{762})^{1.733} \%$$

where k_{762} is the Modulus of Subgrade Reaction, defined as the applied pressure under the loading platen divided by the displacement (normally 1.25mm) with a plate of 762mm (30 inch) diameter. The Modulus of Subgrade Reaction for other plate sizes can be determined using the appropriate conversion factor from Fig 7.4.

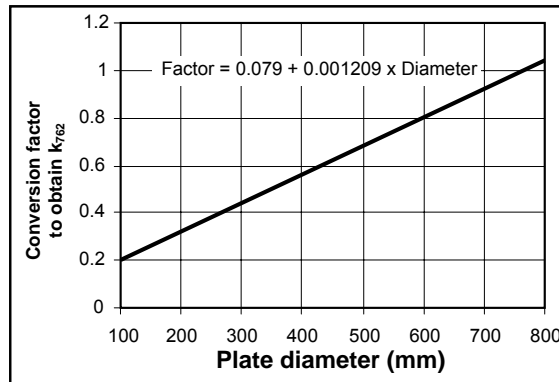

FIGURE 7.4 Conversion Factors for Smaller Plate Sizes

- 7.15 The test is laborious to set up and carry out and requires a heavy vehicle (typically a site truck or excavator) to provide the reaction force. The speed of loading is slow giving poor simulation of traffic loading.

Dynamic Plate Tests

- 7.16 These tests involve dropping a weight onto a platen and measuring the deflection. Usually a damping mechanism (rubber buffers) is incorporated to control the magnitude and duration of the loading. The Specification sets out the requirements for the standard test and its interpretation. The Falling Weight Deflectometer (FWD) measures the stress applied and the resulting deflection of the foundation at several radial positions up to 2.5 metres from the loading plate. Interpretation is generally in terms of the Stiffness Modulus of each foundation layer but is not straightforward and should be carried out by an experienced pavement engineer. If only the central deflection is used to determine a Surface Modulus for the foundation, then interpretation can be carried out as for other Dynamic Plate tests. The Lightweight Dynamic Plate (LWD) apparatus (Figure 7.5) can be used for most foundation materials but care will be required for very stiff foundations, as it may be unable to deliver sufficient load to achieve a measurable deflection.
- 7.17 The Surface Modulus testing, required by the Specification, must be carried out using a Dynamic Plate Test device, which has been properly calibrated to the manufacturer's specification; this includes the FWD as well as the LWD.
- 7.18 The requirements for the equipment including calibration are given in the Specification. If an LWD is used, a correlation exercise with the FWD for the site and for the foundation materials being used will be required as set out in the Specification (MCHW1), Clause 895.



FIGURE 7.5 Lightweight Dynamic Plate Test

- 7.19 If any equipment is proposed which does not fully comply with these requirements, it may be permitted at the discretion of the Overseeing Organisation, provided that it is carefully calibrated against other compliant equipment, for the specific types of material and layer thickness encountered on the site. This calibration would normally be carried out as part of the testing of the Demonstration Area for Performance Designs.

Springbox

- 7.20 The Springbox equipment (Edwards et al, 2005) (Fig 7.6) is a suitable tool for testing unbound granular and some weak hydraulically bound mixtures. It consists of a steel box containing a cubical sample of material, of edge dimension 170mm, to which a repeated load can be applied over the full upper surface. One pair of the box sides is fully restrained and the other is restrained through elastic springs, giving a wall stiffness of 10-20kN per mm.
- 7.21 The equipment enables a realistic level of compaction to be applied to the test material, by means of a vibrating hammer and also includes a facility to introduce water to the sample or drain water from its underside.
- 7.25 Loading takes the form of repeated vertical load applications of controlled magnitude at a frequency of at least 1Hz and no greater than 5Hz. The load capacity is equivalent to a vertical stress of at least 150kPa.
- 7.26 Measurements of both vertical and horizontal (spring restrained) deflection can be made, with 2 measurement transducers for each measure. In the case of vertical deflection measurement, the equipment allows the transducers to make direct contact with the specimen, via holes in the loading platen.
- 7.27 The stiffness modulus of the material can be calculated from the averaged deflections measured over a series of loading patterns.



FIGURE 7.6 Springbox

Chapter 8 REFERENCES

1976

Parsons A.W, "The rapid determination of moisture condition value of earthwork material". Report LR 750, TRRL

1979

Black W.P.M and Lister N.W: "The strength of clay fill subgrades, its prediction in relation to road performance". Report LR 889, TRRL

1984

Powell W.D, Potter J.F, Mayhew H.C and Nunn M.E, "The Structural Design of Bituminous Roads". Report LR1132; TRRL

1989

Jones, H.A and Jones, R.H, 1989(a). Horizontal permeability of compacted aggregates, Proc. 3rd Int'l Symp. Unbound Aggregates in Roads (UNBAR3), Univ. of Nottingham, pp 70-77.

Jones, R.H and Jones, H.A, 1989(b). Granular drainage layers in pavement foundations. Proc. 3rd Int'l Symp. Unbound Aggregates in Roads (UNBAR3), Univ. of Nottingham, pp 55-69.

1997

Mattheson GD and Winter MG, 1997. Use and application of the MCA with particular reference to glacial tills. TRL Report 273. Transport Research Laboratory, Wokingham

1999

Atkinson V, Chaddock B and Dawson. Enabling the use of secondary aggregates and binders in pavement foundations. TRL Report 408. Transport research Laboratory, Wokingham.

2000

Chaddock, B.C.J and Schoepe, B, 2000. The hydraulic and structural behaviour of unbound granular sub-base layers, Proc. 5th Int'l Symp. Unbound Aggregates in Road Construction (UNBAR5), Univ. of Nottingham, pp 297-305.

2003

Lindh, P. and Winter, M.G. "Sample preparation effects on the compaction properties of Swedish fine-grained tills". Quarterly Journal of Engineering Geology and Hydrogeology, 36(4), pp 321-330.

2004

Winter, M.G. "Determination of the acceptability of glacial tills for earthworks". Quarterly Journal of Engineering Geology and Hydrogeology, 37(3), pp 187-204.

2005

Edwards, J.P., Thom, N.H. Fleming, P.R. and Williams, J., 2005. "Accelerated Laboratory Based Mechanistic Testing of Unbound Materials within the Newly Developed NAT Springbox". Transportation Research Record. Issue Number 1913. Journal of the Transportation Research Board. ISBN 0309093864

2006

Chaddock, B. and Roberts, C. Road foundation design for major UK Highways. Published Project Report PPR127. Transport Research Laboratory, Wokingham.

ANNEX A: EQUATIONS OF THICKNESS DESIGN EXAMPLES – PERFORMANCE FOUNDATION DESIGN

In the following equations:

H_{cap} (mm) is capping layer thickness,
 H_{sb} (mm) is subbase layer thickness,
 E_{cap} is capping layer stiffness (MPa),
 E_{sb} is subbase layer stiffness (MPa) and,
CBR is the California bearing ratio of the subgrade (%).
(S) and (D) denotes whether the thicknesses were determined using the subgrade strain criterion (S) or the deflection criterion (D).

Equations for Single-Layer Designs

Foundation class FC1 (Capping only):

For subgrade CBR $\geq 2.5\%$ and $\leq 5\%$, the capping thickness (mm) is the greater of the thicknesses given by the following two equations:

$$H_{cap}(S) = 1.845 \times 10^3 \cdot E_{cap}^{-0.25} (1 - 0.395 \cdot E_{cap}^{-0.025} \ln(CBR))$$

$$H_{cap}(D) = 2.00 \times 10^2 \cdot E_{cap} (\ln(CBR) - 1.538) - 10.918 \times 10^3 \cdot (\ln(CBR) - 1.541)$$

For subgrade CBR $> 5\%$ and $\leq 15\%$, the capping thickness (mm) is given by:

$$H_{cap}(S) = 1.016 \times 10^3 \cdot E_{cap}^{-0.214} (1 - 0.23 \cdot E_{cap}^{-0.026} \ln(CBR))$$

where, the minimum value of H_{cap} permissible is 150 mm and these relationships are valid for capping material with a layer stiffness of between 50 and 100 MPa.

Foundation class FC2 (Subbase only):

For subgrade CBR $\geq 2.5\%$ and $\leq 5\%$, subbase thickness (mm) is given by:

$$H_{sb}(S) = 2.85 \times 10^3 \cdot E_{sb}^{-0.341} (1 - 0.316 \cdot E_{sb}^{0.021} \ln(CBR))$$

For subgrade CBR $> 5\%$ and $\leq 30\%$, subbase thickness (mm) is given by:

$$H_{sb}(S) = 9.25 \times 10^2 \cdot E_{sb}^{-0.202} - 69 \cdot \ln(CBR)$$

where, the minimum value of H_{sb} permissible is 150 mm and these relationships are valid for subbase material with a layer stiffness of between 150 and 250 MPa. Note, these equations are not suitable for subbase materials with a layer stiffness between 250MPa and 350MPa.

Foundation class FC3 (Subbase only):

For subgrade CBR $\geq 2.5\%$ and $\leq 30\%$, subbase thickness (mm) is given by:

$$H_{sb}(D) = 8.44 \times 10^3 \cdot E_{sb}^{-0.48} (1.0 - 0.261 \cdot E_{sb}^{-0.008} \cdot \ln(CBR))$$

where, the minimum value of H_{sb} permissible is 175 mm and these relationships are valid for subbase material with a layer stiffness of between 500 and 1,000 MPa.

Foundation class FC4 (Subbase only):

For subgrade CBR $\geq 2.5\%$ and $\leq 30\%$ subbase thickness (mm) is given by:

$$H_{sb}(D) = 1.53 \times 10^4 \cdot E_{sb}^{-0.4833} (1.0 - 0.234 E_{sb}^{-0.025} \cdot \ln(CBR))$$

where, the minimum value of H_{sb} permissible is 200 mm and these relationships are valid for subbase material with a layer stiffness of between 1,000 and 3,500 MPa.

Equations for Subbase on Capping

The following equations that describe the designs have been developed for subbase on capping foundation class FC2 and subgrade CBR in the range $\geq 2.5\%$ and $\leq 15\%$:

The subbase thickness (mm) is given by:

$$H_{sb}(D) = 8.27 \times 10^4 \cdot (0.4123 \ln(E_{cap}) - 1) E_{sb}^{-(0.2075 + 0.1933 \ln(E_{cap}))} - 21.39 \cdot E_{cap}^{1.745} \cdot E_{sb}^{(0.271 - 0.335 \ln(E_{cap}))} \cdot \ln(CBR)$$

The capping thickness (mm) is given by:

$$H_{cap} = 3.01 \times 10^2 - 56 \cdot \ln(CBR)$$

where, the minimum value of H_{sb} and H_{cap} permissible is 150 mm and these relationships are valid for capping material with a layer stiffness of between 50 and 100 MPa and subbase material with a layer stiffness of between 150 and 250 MPa.

ANNEX B: PROCEDURE FOR ALTERNATIVE PERFORMANCE FOUNDATION DESIGNS

- B.1 Alternative design options may be calculated analytically using a multi-layer linear elastic analysis package. In such cases, the designer must show that all the design criteria given in the following paragraphs (subgrade strain, surface deflection and practical thickness limits) are met.
- B.2 Protection of the subgrade during construction (short term) is based on the calculation of the maximum vertical strain in the subgrade under the action of a standard 40kN wheel load travelling at the top of foundation level, as shown in Figure B.1. Trafficking at lower levels is permitted, but only so long as the deformation limits given in the Performance Specification are not exceeded.

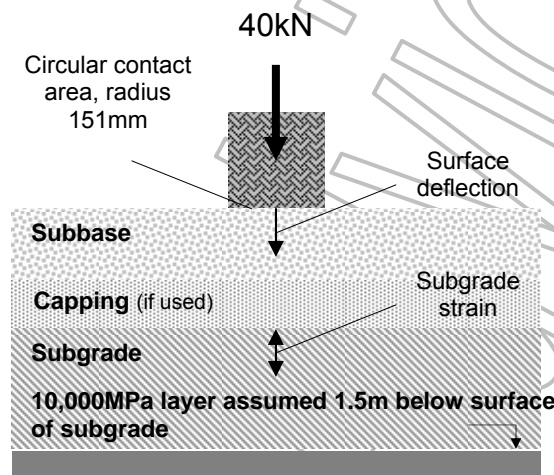

Figure B.1 Input Parameters for Performance Foundation Design

- B.3 Limits on the maximum permitted subgrade strain vary according to the Stiffness Modulus of the subgrade, as shown in Figure B.2. These limits are based primarily on the criteria used in Powell et al (1984) but adjusted for reasons given in Chaddock and Roberts (2006).

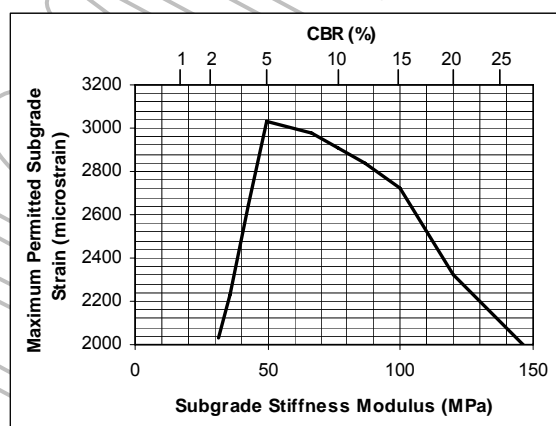

Figure B.2 Subgrade Strain Limits

- B.4 Adequate support for the pavement during its design life, is defined by calculating the deflection of the foundation under the action of a wheel load (or Dynamic Plate load) at top of foundation level, also shown in Figure B.1. The deflection under a given load can be equated to a Surface Modulus for the foundation as a whole. The following are

the maximum deflections permitted for each Foundation Class under a standard wheel load (40kN load over a 151mm radius loaded area).

- Class 1 – 2.96mm
- Class 2 – 1.48mm
- Class 3 – 0.74mm
- Class 4 – 0.37mm

B5 The maximum layer stiffnesses for each Foundation Class listed in Paragraph 4.51 must also be applied to alternative designs. It should also be noted that the values of Poissons ratio of 0.35 for subbase materials and 0.45 for capping, subgrade materials and those with stiffness >10,000MPa are normally adopted.

Design Example 4

Subgrade Stiffness Modulus for design estimated as 50MPa (approximately 5% CBR)
Design a composite Class 4 foundation with 200mm of HBM upper subbase of design Stiffness Modulus 1500MPa over a HBM lower subbase of Stiffness Modulus 500MPa by calculating the thickness of the lower subbase.

Limits applying:

- 1) Minimum lower subbase thickness = 150mm
- 2) Maximum surface deflection under a standard 40kN load = 0.37mm
- 3) Maximum vertical compressive strain in the subgrade = $3030\mu\epsilon$

Theoretical requirements:

- 1) 150mm minimum thickness
- 2) 193mm of lower subbase gives 0.37mm surface deflection
- 3) The upper subbase on its own satisfies the subgrade strain criteria, hence 0mm of lower subbase gives $< 3030\mu\epsilon$ vertical compressive strain in subgrade.

Resulting design:

Take greatest figure = 193mm rounded up to 200 mm of HBM lower subbase (500MPa) overlaid with 200mm of upper subbase (1500MPa).

ANNEX C: PERFORMANCE FOUNDATION DESIGN PROCEDURE – FLOWCHARTS AND EXAMPLES

DESIGN

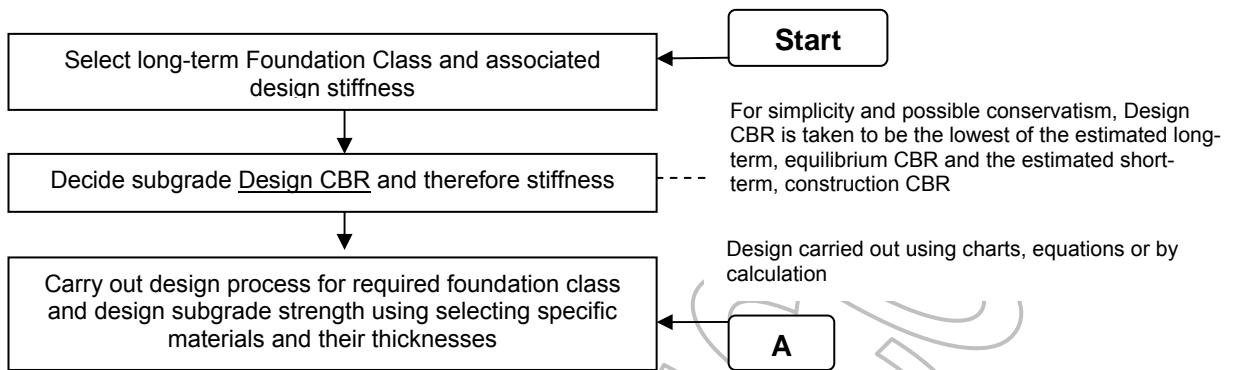

DEMONSTRATION AREA

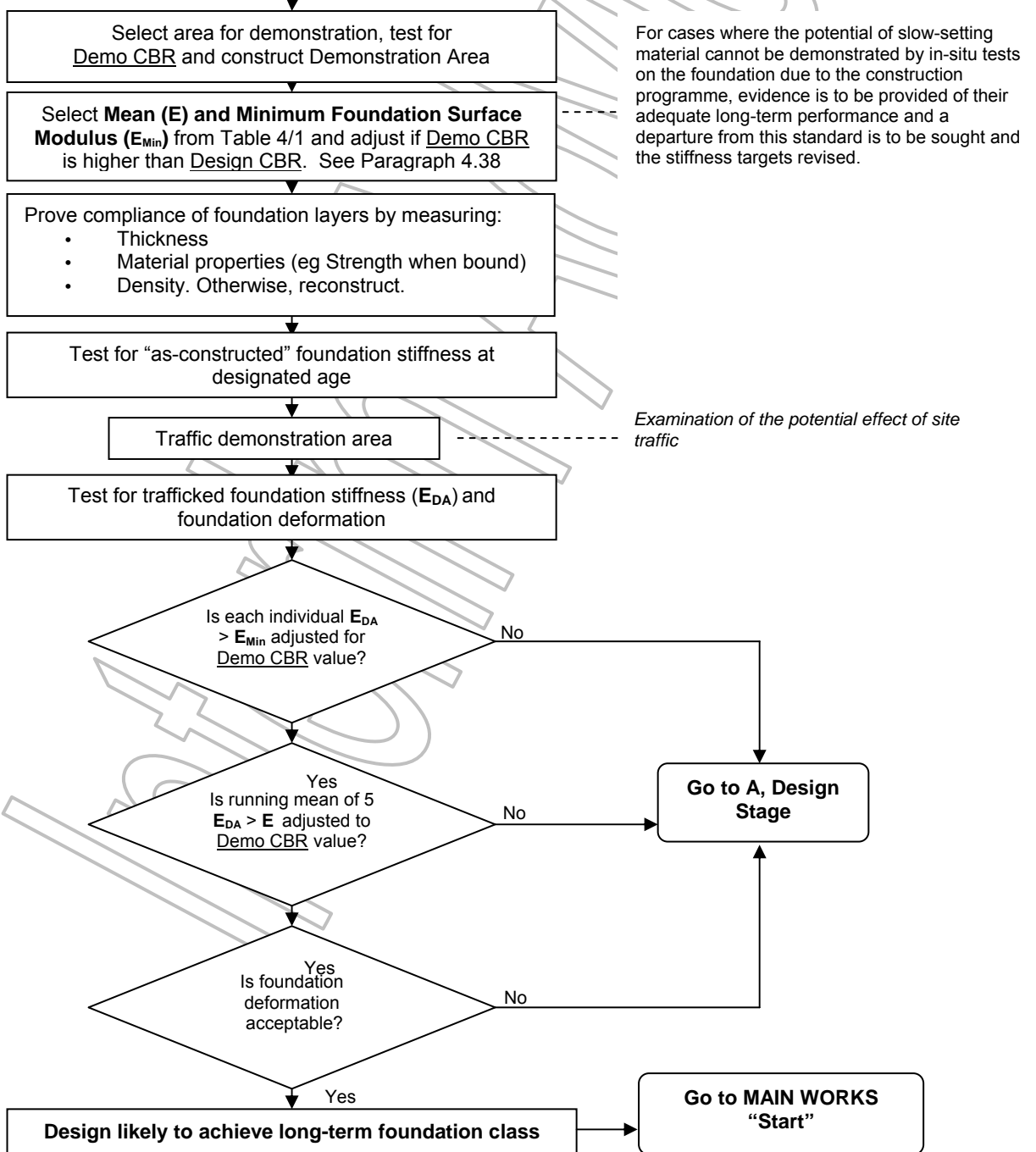

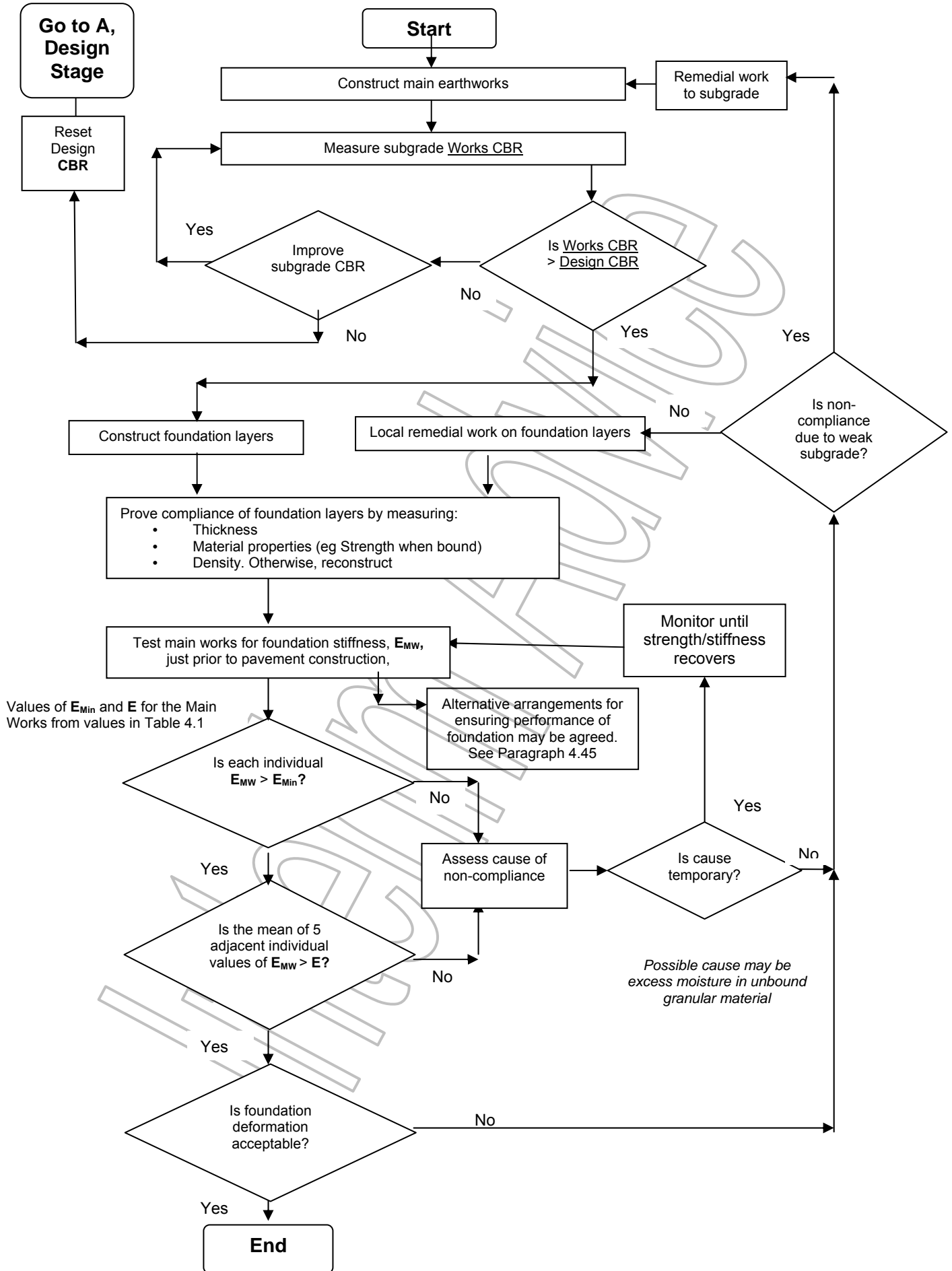

Performance Foundation Design Procedure – Example 5

Design

A Designer estimates the short term CBR for a site as 4% and the long term CBR as 7%. Taking the lower of the two values, the design is based on 4% CBR or approximately 43MPa.

The Designer wishes to use a Type 1 subbase complying with the Specification Series 800 over a locally won capping material to form a Class 2 Foundation. The Designer estimates that the Stiffness Modulus of the Type 1 is 150MPa and the Stiffness Modulus of the capping material is 75MPa. Using a layered linear elastic analysis, the Designer estimates that the design requires 211mm of capping and 123mm of subbase. As the minimum thickness permissible for Type 1 is 150mm, he adjusts the design to 200mm of capping and 150mm of Type 1 subbase (total 350mm). Construction thicknesses are selected taking into account permitted level tolerances.

Demonstration Area

The Demonstration Area is constructed on site in order that the design assumptions can be checked. Using Table 4.1 the requirements at the top of the foundation for a Class 2 unbound foundation are a Mean Surface Modulus of 80MPa and a Minimum Surface Modulus of 50MPa (assuming the design CBR is correct).

The subgrade in the Demonstration area is checked and is found to be at the design CBR of 4%. Construction of the Demonstration Area proceeds to prove the production and placement process for the capping and subbase material. The density and material properties are checked against the requirements of the relevant clauses of Specification Series 600 and 800. The constructed layer thicknesses comply with the design requirements.

After a specified time period Dynamic Plate Tests are carried out at top of foundation and the results compared to the Mean and Minimum Surface Modulus values. It is found that the Demonstration Area does not achieve the Target Value of 80MPa. The Designer asks for the locally won capping material to be tested in the laboratory. The results show that the capping has a stiffness of 50MPa rather than 75MPa that had been assumed. The design is recalculated to be 185mm of capping and 185mm of subbase (total 370mm). A second Demonstration Area is constructed and the Mean and Minimum Surface Modulus values are achieved. A trafficking trial is then undertaken to check deformation susceptibility.

Main Works

The values from the Dynamic Plate Tests are satisfactory and the design is taken forward for the Main Works. The Mean and Minimum Surface Modulus values are those given in Table 4.1 (i.e. 80MPa and 50MPa).

During the Main Works, subgrade CBR must be assessed every 60m. If the CBR falls below the value assumed in the design (i.e. 4%) appropriate remedial action must be taken. Density and material properties of the subbase and capping must comply with the appropriate clauses of Specification Series 600 and 800.

Performance Foundation Design Procedure – Example 6

Design

A Designer estimates the short term CBR for a site as 8% and the long term CBR as 5%. Taking the lower of the two values, the design is based on 5% CBR or approximately 50MPa.

The Designer wishes to use a slag bound mixture (SBM) complying with the Specification Series 800 as subbase to form a Class 4 Foundation. A laboratory investigation has been carried out using the static stiffness modulus apparatus after curing the SBM for 28 days at 40°C (BS EN 13286-43). The results gave an average Modulus of Elasticity for the SBM of 10,000MPa. The Designer takes 10% of this value for his calculations (i.e. 1,000MPa) to take account of degradation and likely in-situ density (see Para 5.25). Using Figure 4.5, the Designer estimates that a layer thickness of 380mm of SBM is required. Construction thicknesses are selected taking into account permitted level tolerances.

Demonstration Area

The Demonstration Area is constructed on site in order that the design assumptions can be checked. Using Table 4.1 the requirements at the top of the foundation for a Class 4 slow curing foundation are a Mean Value of 300MPa and a Minimum Value of 150MPa (assuming the design CBR is correct).

The subgrade in the Demonstration area is checked and is found to have a CBR of 7% following a recent dry spell. Therefore the top of foundation Target Value and Minimum Value must be adjusted, using Paragraph 4.39:

$$\begin{aligned}\text{Adjusted Target Value} &= 300 \times [1+0.28 \times \ln(7/5)] \\ &= 328\text{MPa} \\ \text{Adjusted Minimum Value} &= 150 \times [1+0.28 \times \ln(7/5)] \\ &= 164\text{MPa}\end{aligned}$$

Construction of the Demonstration Area proceeds to prove the production and placement process for the SBM. The constructed layer thicknesses comply with the design requirements. Testing is undertaken as required by the Specification Series 800 for density and compressive strength or tensile strength and stiffness.

After a specified time period (generally 28 days for slow-curing mixtures) Dynamic Plate Tests are carried out at top of foundation. A trafficking trial is then undertaken to check deformation susceptibility and stiffness loss. Dynamic Plate Tests are repeated and the results compared to the adjusted Mean and Minimum values. The results are found to be satisfactory.

Main Works

The design is taken forward for the Main Works. Having proved the adequacy of the design assumptions in the Demonstration Area, the Mean and Minimum Values revert back to those given in Table 4.1 (i.e. 300MPa and 150MPa).

During the Main Works, subgrade CBR must be assessed every 60m. If the CBR falls below the value assumed in the design (i.e. 5%) appropriate remedial action must be taken. Density and material properties of the SBM must comply with the appropriate clauses of Specification Series 800.

Section 5 Draft Specification Clauses

890 Performance Related Specification for Foundations

General

- 1 Performance Foundations as defined in HD 25 (DMRB7.2.2) must be constructed in accordance with Clauses 890 to 896.
- 2 The foundations for a scheme must be divided into Foundation Areas defined in Appendix 7/1. Each Area shall be defined by the Design subgrade strength or by different foundation materials used in the design.
- 3 The structure of each Foundation Area must be defined in Appendix 7/1 as either Foundation Class 1, 2, 3 or 4 and foundation materials and minimum layer thicknesses to be constructed must be tabulated
- 4 The tests to measure performance in accordance with this specification must be carried out for each Foundation stage at each of the following stages of construction:
 - (i) Top of Subgrade
 - (ii) Top of Foundation
- 5 The stiffness modulus performance requirements for the top of a foundation are set out in the Chapter 4 of the draft HD25 for the following situations:
 - Long-term Foundation Class
 - Short-term Mean Foundation Surface Modulus to be exceeded by the running mean of five consecutive measurements
 - Short-term Minimum Foundation Surface Modulus to be exceeded by all individual measurements.

Materials

- 6 All foundation materials must comply with Series 600 and Series 800 clauses except that a layer thickness of up to 250mm may be used for layers other than the uppermost foundation layer.
- 7 The use of all materials used in foundations must be acceptable to the Environment Agency and other bodies responsible for the local environment and for water quality and must not result in a deleterious reaction with other pavement or subgrade materials.
- 8 Where a Contractor's proposed alternatives are permitted for unbound granular materials, no such materials must have a plasticity index greater than 6% when tested according to BS1377: Part 2 on material passing the 425 micron sieve unless the fraction of such material is less than 10% of the whole.

Placement and Compaction

- 9 Class 9D or 9E stabilised materials must not be placed or constructed above Class 6F granular material or Class 6S granular filter layer material.

- 10 The minimum material layer thicknesses to be constructed as defined in Appendix 7/1 must include an allowance for construction tolerances. The contractor must also make additional allowance for thickness or quality of material to ensure there is no damage if the foundation is to be used as a haul road.
- 11 The minimum compacted layer thickness must be the greater of the following: 2.5 times the maximum particle size or 150mm for bound layers, or 80mm for unbound layers.
- 12 Unbound foundation material may be compacted in a layer thickness up to 250mm except for the uppermost foundation layer for which the thickness must not exceed 225mm.
- 13 Unless stated otherwise in Appendix 7/1, no restriction is placed on the method of compaction of unbound materials so long as the dry density requirements given in Clause 894 are achieved and sub-clauses 12 to 16 of this Clause are satisfied.
- 14 For Performance Foundations, compaction of materials covered by Clauses 614, 615 and 643 must be carried out to Clause 894.
- 15 For cement and other hydraulically bound mixtures to Clauses 821, 822, 823, 830, 831, 832, 834 and 840, the compaction plant and method specified in Clause 814 must be used.

Subgrade Protection

- 16 The Contractor must limit any areas of completed formation to suit the output of plant in use and the rate of deposition of sub-base. No prepared formation must remain continuously exposed to rain causing degradation or to be left uncovered overnight.

891 Demonstration Area for Performance Foundations

General

- 1 For each Foundation Area, a Demonstration Area must be prepared using the same methods, materials, thickness and compaction as proposed for the permanent works. Each Demonstration Area shall be not less than 400m² and not less than 60m long. For foundations constructed using HBM to Clause 810, the demonstration area shall comply with the requirements of Clause 817.
- 2 Records of the performance test results for each construction stage, referenced to the following condition details must be presented to the Overseeing Organisation in an electronic spreadsheet format, prior to construction of the same foundation type for the Main Works:
 - (i) Subgrade CBR value immediately before foundation construction
 - (ii) Date and Time of mixing (for stabilised and slow-setting materials)
 - (iii) Date and time of placing and compaction
 - (iv) Date of performance testing
 - (v) Values of Surface Modulus recorded
 - (vi) Values of material properties including density and layer thickness
 - (vii) Weather conditions including temperature
 - (viii) Details of samples taken for testing.

- 3 The materials placed in the Demonstration Area may form part of the Permanent Works, provided that they meet the requirements of the Permanent Works.
- 4 Foundation layers containing at least 3% CEM1 cement by dry mass of mixture must not be tested or trafficked until 7 days after placing unless a strength criterion has been agreed with the Overseeing Organisation.
- 5 Where the foundation includes any HBM, then 5 laboratory specimens must be manufactured from samples recovered at locations uniformly distributed across the Demonstration Area and tested in accordance with the requirements for that material.
- 6 Where the completed Demonstration Area meets all the requirements, the methods, materials and thicknesses used must not be changed for the construction of the Main Works without further testing in a Demonstration Area.

Trafficking Trial

- 7 The Contractor must undertake controlled trafficking on the Top of Foundation Stage of construction in the Demonstration Area.
- 8 Trafficking must be carried out using a heavy goods vehicle with axle configuration and load as required by Clause 816.28. The number of passes should be equivalent to 1000 standard axles as given in Clause 802 or as agreed otherwise. The deformation must be measured in accordance with, and must not exceed the limits stated in Clause 896.
- 9 Foundation Surface Modulus performance tests at the Top of Foundation that includes bound materials, must be carried out both before and after a Trafficking Trial. Each individual Surface Modulus measurement and the running mean of 5 consecutive measurements of the later series of tests must exceed the values in Clause 891 Sub-clause 16.

Top of Subgrade Performance Assessment

- 10 The short-term subgrade CBR strength within the Demonstration Area must be determined in accordance with Clause 893 at not less than 5 locations, distributed uniformly over the Demonstration Area. The locations are to be identified to an accuracy of 0.5m. The measurement of strength must be taken at formation level or at sub-formation level if capping is part of the foundation design.
- 11 The Top of Subgrade within the Demonstration Area must be proved by not less than 5 in situ density measurements in accordance with the requirements of Clause 894, coinciding with the CBR test locations.
- 12 Where in-situ stabilisation of the subgrade is to be used as part of or as the first foundation layer, then the subgrade CBR strength must be measured immediately below the depth of the stabilisation by means of a Dynamic Cone Penetrometer, to the requirements of Clause 893.
- 13 Where the subgrade CBR test values are less than the Design CBR, the area must either be improved, and the improvement applied to the permanent works, or the Design CBR reset and another foundation designed, constructed and proved.

Top of Foundation Stage Performance Assessment

- 14 Measurements of the short-term Surface Modulus must be carried out as detailed in Clause 895. A minimum of 25 stiffness tests must be completed, distributed uniformly over the Demonstration Area, with at least five of these tests located above the Top of Subgrade CBR strength and density tests.
- 15 The foundation layer within the Demonstration Area shall be proved by not less than 5 in-situ density measurements, in accordance with the requirements of Clause 894. These 5 tests must be located above the five Top of Subgrade CBR strength and density test locations.
- 16 The short-term Surface Modulus performance requirements for each individual value and for the running mean of five consecutive measurements must be equal to or greater than the requirements for the particular Foundation Class identified in Appendix 7/1 following adjustment in accordance with the procedure in the draft HD25 Chapter 4 to the median value of the five subgrade CBR values from the Demonstration Area.
- 17 Where the Surface Modulus performance measurements do not meet the requirements detailed in this Clause, the foundation must be re-designed and another Demonstration Area constructed and the design proved.

892 Permanent Works for Performance Specified Foundations

General

1. For each Foundation Area, records of the performance test results for each construction stage, referenced to the following condition details must be presented to the Overseeing Organisation in an electronic spreadsheet format, prior to construction of the pavement layers above:
 - (i) Subgrade CBR value immediately before foundation construction
 - (ii) Date and Time of mixing (for stabilised and slow-setting materials)
 - (iii) Date and time of placing and compaction
 - (iv) Date of performance testing
 - (v) Values of Surface Modulus recorded
 - (vi) Values of material properties including density and layer thickness
 - (vii) Weather conditions including temperature
 - (viii) Details of samples taken for testing.
2. Foundation layers containing at least 3% CEM1 cement by dry mass of mixture must not be tested or trafficked until 7 days after placing unless a strength criterion has been agreed with the Overseeing Organisation.

Top of Subgrade Stage of Construction Performance Assessment

- 3 The short-term subgrade CBR strength must be determined according to Clause 893 at 60m intervals along each lane of prepared subgrade and staggered by 30mm between adjacent lanes. At least 10 tests shall be carried out for each prepared Foundation Area. The location of each test must be identified to the nearest 0.5m.

The measurement of strength must be taken at formation level or at sub-formation level if capping is part of the foundation design.

- 4 The foundation must not be constructed in areas where the subgrade strength is less than the Design CBR.

Top of Foundation Performance Assessment

- 5 The top of the foundation must be tested for Surface Modulus in accordance with Clause 895 immediately prior to construction of overlying pavement layers and at 20m intervals along each lane, staggered by 10m between adjacent lanes. Tests should coincide with subgrade CBR and Density tests where appropriate.
- 6 The short-term Surface Modulus performance for each individual measurement and for the running mean of 5 consecutive measurements must be equal to or greater than the minimum and mean values set out in Chapter 4 of the draft HD25 for the Foundation Class and identified in Appendix 7/1.
- 7 A foundation containing unbound materials that fails to comply with the performance requirements of this Clause when the recorded moisture content is in excess of that in the Demonstration Area, may be re-tested for compliance when the foundation moisture content has reduced to that of the Demonstration Area.
- 8 Where the Surface Modulus performance values do not meet the requirements detailed in this Clause, the foundation must be re-designed and another Demonstration Area constructed and the design proved.
- 9 Density tests, to the requirements of Clause 894 are to be performed at a spacing of 200 metres staggered along each lane of the road when placement and compaction to Clauses 802 and 813 have been followed; otherwise the spacing of these tests must be every 60m, coinciding with Surface Modulus tests. Tests performed in adjacent lanes must be staggered by 30m.
- 10 Wheelpath deformation must be monitored and measured along all lengths of prepared foundation in accordance with the requirements of Clause 896 and the measured values must not exceed those stipulated in that Clause.

893 CBR Strength Measurement

- 1 CBR strength measurements of the prepared subgrade must be carried out using a Dynamic Cone Penetrometer (DCP) unless the type of soil is inappropriate for such testing when Dynamic Plate testing must be used. The DCP equipment must incorporate an 8kg steel drop weight that falls vertically through 575mm and makes contact with a steel anvil. This anvil must be rigidly attached, via steel rods (less than 20mm diameter), to a 20mm diameter 60° steel cone, which is driven vertically into the ground. Also see HD29 (DMRB 7.3.2).
- 2 The result for each test must be expressed as a 50th percentile penetration rate in millimetres per blow between 50mm and 550mm of penetration from top of subgrade level. If the penetration rate is less than 2mm per blow, then the test should be aborted with one further test attempted nearby.

- 3 Soil strength expressed as mm/blow must be converted to a CBR value using the following relationship:

$$\text{Log}_{10} (\text{CBR}) = 2.48 - 1.057 * \text{Log}_{10} (\text{mm/blow})$$

where CBR is given as a percentage value and the penetration rate of the cone is given in units of mm/blow.

894 Density Measurement

- 1 Each stage of foundation construction must be tested for in-situ density by a nuclear density gauge in transmission mode, calibrated for the material being tested, in accordance with BS1377: Part 9 for unbound materials or Clause 870 for cement and other hydraulically bound mixtures.
- 2 The unbound material used in each compacted foundation layer must achieve a minimum in-situ dry density, when tested in accordance with BS1377: Part 9, of 95% of the maximum dry density, as determined from the method in BS EN 13286-4. Cement and other hydraulically bound mixtures must attain a minimum in-situ wet density, when tested in accordance with Clause 870, of 95% of the average wet density of at least five cubes manufactured to BS EN 13286-51.
- 3 Maximum dry density (for unbound materials) or maximum wet density (for cement and other hydraulically bound mixtures) must be determined for every 1000 tonnes of material unless otherwise stated in Appendix 7/1.
4. Other non-nuclear density gauges will be permitted with approval if they can be calibrated to the nuclear density gauge on the material being tested and can be shown to measure density over the thickness of the layer being tested.

895 Surface Modulus Measurement

- 1 Surface Modulus testing must be carried out using a Dynamic Plate Test device, which has been calibrated to the manufacturer's specification. Regular checking and calibration of the load cell and deflection sensors must be carried out as recommended by the manufacturer. The equipment must be capable of producing a peak stress of 100kPa with a pulse rise time of between 8 to 12 milliseconds, applied through a rigid circular plate of 300mm diameter. Both the applied load and the transient deflection, measured directly on the tested surface, must be recorded. The deflection measurement transducer must be capable of measuring deflections in the range 40-1500 microns. The accuracy of the readings should be ± 0.1 kN for the load and ± 2 microns for deflection.
- 2 The peak stress applied during each test shall be selected to produce as high a deflection as possible within the measurement range of the deflection sensor.
- 3 The following procedure is to be adopted for dynamic plate testing. Each test site should be stable and flat and free from water, ice and snow. The temperature down to 100mm below the surface should be at least 4°C. For a lightweight test device, at least 10 drops are necessary at the beginning of each test session to warm up the rubber buffers. At each test point, 3 initial 'seating' drops shall be carried out to bed the plate into the surface. Three further drops shall then be carried out. The results from the last set of three drops shall be averaged to give the Surface Modulus applicable to that test point.

- 4 The stiffness modulus shall be computed at each point tested, using the following formula:

$$E = \frac{2(1 - \nu^2) \times R \times P}{D}$$

where :

- E = Foundation Surface Modulus (in MN/m² or MPa)
 ν = Poisson's Ratio (ν, by default, = 0.35)
 R = Load Plate Radius (R, by default, = 150mm)
 P = Contact Pressure (in kPa)
 D = Deflection under the centre of the plate (in microns)

5. If a lightweight test device is used, it must be correlated to an FWD which will remain the reference test method. The following procedure must be used to correlate a lightweight device: The FWD and the lightweight devices are to both to be used on the same material and at adjacent test positions in the demonstration area for the 25 measurements points. The Surface Modulus values obtained from the two devices are to be compared and the square of the correlation coefficient (r²) is to be calculated, if this value is more than 0.45 then there is considered to be sufficient correlation between the two devices. An adjustment factor should then be calculated as the mean of the ratios of each FWD value to lightweight value. The lightweight device readings are to be adjusted by this factor for all further readings on that material for that scheme.

896 Wheelpath Deformation Measurement

- 1 Ruts that develop under construction traffic, measured in accordance with this Clause, shall nowhere exceed the following limits:
- All stabilised/bound surfaces – 10mm
 - < 250mm thick granular material – 30mm
 - ≥ 250mm thick granular material – 40mm
- 2 At each point, the cumulative rut, calculated by summing the deformations from each trafficked foundation layer shall not exceed 50mm.
- 3 Wheelpath Deformation measurement shall be carried out using a straight edge with a length of at least 2m. The straight edge shall be placed transverse to the rut and raised clear from the rut by two identical blocks. The blocks shall be placed on undisturbed material outside of the wheel path. The amount of deformation shall be the difference between the deepest vertical measurement from the straight edge to the surface of the foundation (A) and the height of the blocks (B).

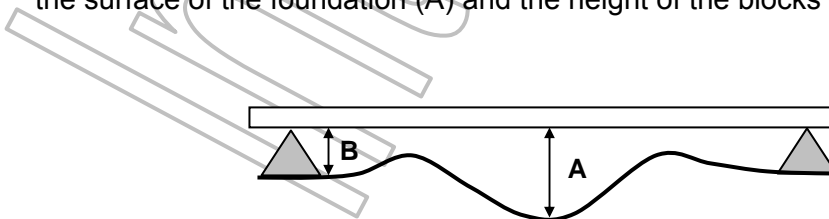

Deformation = A – B.

Section 6 Draft Notes for Guidance Clauses

NG 890 Performance Related Specification for Foundations

General

- 1 Because of the variability of subgrades, the type and the design of foundations may have to be varied during construction. It may also be necessary to adjust the number of Foundation Areas based on the various subgrade CBR strength values measured on site.
- 2 The use of capping will often provide an excellent platform for the construction and compaction of the foundation. A capping layer enables construction plant to lay the subbase and can provide a good base for the necessary compaction to be achieved. The provision of a capping layer may be particularly appropriate for lower strength subgrades. The benefit of providing a capping layer can be taken into account as part of the Performance Foundation design process.
- 3 The requirements for minimum thickness layers for the various Foundation Classes are explained and detailed in Chapter 4 of the draft HD 25.
- 4 The short-term, i.e. during construction, subgrade CBR strength would typically be expected to differ from the long-term, i.e. under the completed pavement, equilibrium strength. Similarly, measurements of Foundation Surface Modulus during pavement construction are likely to differ from the long-term surface stiffness modulus assumed for design.
- 5 The measurement of Foundation Surface Modulus at the top of the foundation serves several purposes:
 - To identify inadequate subgrade performance either not found during previous testing or where performance has reduced; eg. where water has been allowed to enter the foundation.
 - To identify inadequate upper foundation layers performance.
 - To identify degradation of the foundation, possibly brought about by construction traffic.
 - To quantify the potential degradation which will be identified during a Trafficking Trial to Clause 891 by measurement of the Foundation Surface Modulus both before and after trafficking, prior to construction of the next stage of the Permanent Works.
- 6 Testing for Surface Modulus at each intermediate foundation level where compaction is carried out is recommended to identify any areas of concern as soon as possible and to ensure that the completed foundation will meet the requirements. Results for testing at intermediate layers will permit checks to be made against expectations as work proceeds.

Materials

- 7 Restrictions may be placed on some materials including unburnt colliery spoil and certain other industrial by-products. Further information can be found in the Specification Series 600 and 800. Expert advice should be sought when proposed alternative materials are proposed.

- 8 Demonstration Areas (Clause 891) afford an opportunity for gaining experience of the materials to be used as well as adjusting construction procedures and/or design thicknesses. They also permit Surface Modulus measurement with dynamic plate apparatus to be carried out.
- 9 For all materials, including Contractor's proposed alternative materials, laboratory testing forms an important step in characterising the mechanical properties prior to developing foundation designs. Advice is provided in the draft HD25, and the following should be noted:
- The Triaxial test (BS EN 13286-7) provides stiffness modulus and shear strength data for unbound materials, but may not be suitable for materials having large particle size. For cement and other hydraulically bound mixtures, BS EN 13286-43 describes two techniques for stiffness modulus measurement, whereas Parts 40, 41 and 42 describe different strength measurements.
 - Alternatively, the 170x170x170mm 'Springbox' which fits inside a NAT loading frame is suggested as a suitable tool for the measurement of mechanical properties of unbound granular and weak hydraulically bound mixtures. The Springbox allows the material to be tested in a realistic moisture state; soaking followed by a 24 hour drainage period is generally considered appropriate.
 - Characterisation of granular materials can be made using the 300x300x150mm Shear Box (see Transport & Road Research Laboratory Report RR64) where, if the 'peak shear stress ratio (PSSR)' is greater than 2.8, then the material is very likely to be suitable for direct trafficking by road vehicles. If it is between 1.9 and 2.8 there is some risk of rut development, and for PSSR less than 1.9 rutting is likely, such materials may still be suitable in the long-term as long as they are protected during the construction process.
 - A further practical alternative for in situ testing is the Dynamic Cone Penetrometer (DCP), see Clause 893, where experience suggests that materials with a penetration rate of less than 17mm per blow (>15% CBR) are likely to be suitable for direct trafficking (unless they are unsuited to such testing due to the presence of large particles) and for Class 1 foundations. The uppermost layer of a Class 2 foundation would usually achieve a DCP penetration rate of less than 9mm per blow (>30% CBR).
- 10 Crushed rock or sand filter layers of 50mm minimum thickness, made using Class 6S granular filter layer material, can be used to prevent the ingress of cohesive particles from the top of the subgrade into an open graded foundation layer and can also provide a drainage path. A filter layer is not generally required if Class 6F granular material is used.
- 11 BS EN 13285 requires separate classes for Class 6F granular material from sources other than the excavated parts of the same Site. It should be noted that part of the material characterisation relates to where the materials has been obtained.

Placement and Compaction

- 12 For thicker compacted foundation layers than those permitted in Clause 890.13, the contractor must obtain separate departure approval, and describe fully the method by which the density requirements of Clause 894 are to be achieved and demonstrated throughout the full depth of material.

NG 891 Demonstration Area for Performance Foundations

- 1 For slow curing HBMs, an extended curing period may be specified in Appendix 7/1 before testing and augmented by laboratory evidence showing that the expected 360 day performance will be met. A shorter period of time between laying and testing may be appropriate for a particularly slow curing HBM to ensure the stability of the mixture in the absence of bond in the short-term and confirm that the material is suitable for trafficking and construction of the next stage. A series of tests may also be appropriate to show the rate of gain of strength.

Trafficking Trial

- 2 In certain circumstances, a trafficking trial may not be necessary and it may be omitted subject to a Departure from Standard. Trafficking at an intermediate stage will provide contractors with reassurance that materials will meet final performance requirements. Testing for stiffness modulus at different times will provide guidance on the possibility of damage to foundation layers by construction traffic.
- 3 With a foundation material for which an increase of water content may affect the stiffness or the resistance to deformation, it is also recommended that a trafficking trial be carried out in a wetted condition. Wetting of the Demonstration Area and re-trafficking is intended to assess likely performance in wet weather. It is suggested that sufficient volume of water to cover the trial area to a depth of 10mm is spread as uniformly as possible and that a period of 1 hour is then allowed prior to re-trafficking. Failure to test in this way may result in rutting at a later date and foundation failure. The moisture content of the material should be recorded at the time of each trafficking trial.
- 4 If the measured deformation is in excess of the requirements of Clause 896, then either the foundation should be improved and subsequently proved by another Trafficking Trial, or the planned works should be adjusted to reduce the construction traffic. If the foundation is to be trafficked by very heavy vehicles (e.g. to transport bridge segments), additional consideration should be given to proving the performance of the foundation under these vehicle loads. Whether a Trafficking Trial is performed or not, it will still be the responsibility of the Contractor to ensure that the foundation meets the requirements specified for the Permanent Works in Clause 896.
- 5 The purpose of trafficking a Demonstration Area is to understand the behaviour of the foundation layers under construction traffic and to ensure that the subgrade is not overstressed. Based on a successful trial it may be concluded that the level concerned is able to withstand trafficking without any special precautions. However, often with marginal materials, special precautions in the form of a limit on traffic movements, a protection layer, or restricted movements in wet weather are necessary. The trial may help to make decisions about such restrictions.
- 6 Care may be necessary for a trafficking trial on a foundation including Class 6F3 material. This material may sometimes appear satisfactory in the short term but deform significantly later. A static test, for example a 12T axle parked for 24 hours, is likely to reveal if a deformation problem exists.

Top of Subgrade Performance Assessment

- 7 For demonstration area and for permanent works where stabilisation or other ground improvement is being used as part of formation preparation, the subgrade strength should be measured at formation level when these works are completed.

Top of Intermediate Foundation Layers Performance Assessment

- 8 It may be appropriate for the intermediate stage of the foundation in the Demonstration Area to be tested to determine the surface modulus value. The value that should be achieved should be agreed beforehand with the designer and used to ensure that the full foundation will achieve the required stiffness.

Top of Foundation Performance Assessment

- 9 Where the designer considers that the foundation may be moisture susceptible, wetting should be carried out to reflect the most pessimistic moisture condition anticipated on site. The foundation shall then be re-tested for stiffness modulus. The results of these tests shall also be reported to the Highways Agency (Overseeing Organisation) to assist in optimising future pavement design.

NG 892 Permanent Works for Performance Foundations

General

- 1 For slow curing HBMs, an extended curing period may be specified in Appendix 7/1 before testing and augmented by laboratory evidence showing that the expected 360 day performance will be met. A shorter period of time between laying and testing may be appropriate for particularly slow curing HBM to ensure the stability of the mixture in the absence of bond in the short-term and confirm that the material is suitable for trafficking and the construction of the next 'stage'.

Top of Subgrade Performance Assessment

- 2 It is important that the subgrade fully meets the design CBR value. Additional testing may be necessary to identify the extent of weaker areas and their depth. Areas of lower value should be identified and suitably treated. Careful attention is necessary to ensure good drainage paths are available and water susceptible materials are handled responsibly. Trapped water must always have routes to drain. Drainage to the works should always be completed and connected before road foundations are constructed.
- 3 Remedial measures are also required to any area of subgrade whose CBR strength falls below the Design CBR due to disturbance caused by inappropriate actions on the part of the Contractor,

Top of Intermediate Foundation Layers Performance Assessment

- 4 Tests of performance at intermediate levels can be compared with those values obtained from the Demonstration Area in order to give confidence that the performance requirement at the Top of the Foundation will be achieved.

Top of Foundation Performance Assessment

- 5 The minimum age of the bound material at which the Foundation Modulus should be measured is typically 7 days for faster setting CEM 1 Cement bound materials but longer for slower setting HBMs dependent on strength development. It is advisable for the foundation not to be trafficked during this period.
- 6 It is useful to plot the running mean of five consecutive Surface Modulus results against the site chainage as the trend in Foundation Surface Modulus may give notice of a possible future non-compliance.
7. Allowance should be made by the contractor for further subgrade CBR strength tests at locations where either potential concern exists, or where evidence of poor subgrade condition, or soil weaker than expected, is observed.
- 8 It is only permissible for the Contractor to change material specifications and layer thicknesses in order to increase (and not decrease) the foundation quality, as judged by foundation stiffness, in the Permanent Works relative to that approved in a Demonstration Area.

NG 893 CBR Strength Measurement

General

- 1 For coarse-grained materials, there might be an appreciable difference between CBR values obtained in-situ and in the laboratory, with the in-situ values being lower due to the effects of confinement in the laboratory test mould (although this should not be confused with low values resulting from exposure to rainfall or a high water table). This difference should be taken into consideration when specifying in-situ requirements in Appendix 7/1.

Dynamic Cone Penetrometer (DCP)

- 2 Further details of the calculation of subgrade CBR strength are provided in HD30 (DMRB 7.3.7)
- 3 Other dynamic cone equipment may only be permitted providing it has been calibrated against equipment meeting the requirements of Clause 893, on the same type of materials.
- 4 The calculation of the 50th percentile penetration rate will not be normally influenced by small stones in a generally cohesive material.
- 5 Where laboratory CBR tests have been carried out on the subgrade material, the DCP values should be calibrated to those of the laboratory tests.

NG 894 Density Measurement

- 1 Density testing of foundation layers is important to ensure that strength is provided through the full depth of the foundation layers and that secondary compaction does not take place. Density values can be low if the material is too dry during compaction.
- 2 In interpreting density results, due account should be taken of the variation in maximum dry or wet density with composition of the material; the grading envelope for foundation materials can be very wide. Where possible, information on the variation of density with gradation for the materials proposed should be used.
- 3 For coarse materials it may not be possible to assess density using the nuclear density meter. Alternative standard, but time consuming, methods based on excavating a measured mass of material and determining the volume of the hole created are permitted by the Specification (subject to Overseeing Organisation approval) and may need to be adopted.

NG 895 Stiffness Modulus Measurement

- 1 When the device applies its maximum stress, especially on lower class foundations and where intermediate stages are tested, the deflection of the structure tested can be over 1000 microns, whereas for the highest foundation class, maximum deflection of only about 50 microns will be produced. A peak stress of 100kPa should be targeted for Foundation Classes 1 and 2 and 200kPa for Foundation Classes 3 and 4, unless the deflection measurement typically falls outside the range 100-1000 microns.
- 2 For unbound materials, normally 3 drops are necessary to ensure satisfactory seating before testing. For bound materials, one drop may confirm stability and satisfactory operation before testing. No more than 10 drops in total should be applied to unbound materials to ensure that there are no unrepresentative results.
- 3 If any equipment is proposed which does not fully comply with the Specification, it may be permitted at the discretion of the Highways Agency (Overseeing Organisation), provided that it is calibrated against equipment complying with the Specification for the specific types of material and layer thickness encountered on the site. This calibration would normally be carried out as part of the Demonstration Area testing.

NG 896 Wheelpath Deformation Measurement

- 1 The limit on rutting is primarily intended to ensure that significant ruts (>20mm) at subgrade level are avoided, to prevent accumulation of water and local subgrade softening. If the subgrade is sufficiently permeable, then this problem will not arise. It may also be possible for the Contractor to cut a trench and to prove that, notwithstanding the rut at the surface, no significant subgrade rut is present. Some sands and gravels may rut excessively during construction, however, following re-profiling and compaction, they may achieve satisfactory properties for placement of the upper layers and, once confined by the pavement, may perform satisfactorily in the long term.

- 2 The more stringent rut limits applying to stabilised/bound surfaces recognises the fact that, in practice, if visible rutting occurs in such materials, then this rutting will be accompanied by significant loss of stiffness, which is likely to result in non-attainment of the desired Foundation Class.
- 3 Whilst the presence of shoulders to a rut is indicative of a deformable material, and this may provide valuable information during a trafficking trial, the actual specified measurement of deformation is based on the change in level from an untrafficked datum to the bottom of the rut. This is because this measure is more closely related to deformation taking place in the subgrade.
- 4 It is the Contractor's responsibility to ensure that the foundation does not suffer excessive deformation. If a foundation needs to be re-profiled during foundation construction, then the implication is that the foundation has already failed to comply with the Specification. Re-profiling alone may not stop further deformation and may disguise problems for the future such as ponding of water in ruts in the subgrade.