**VOLUME 9 NETWORK - TRAFFIC
CONTROL AND
COMMUNICATIONS**
SECTION 2 INTRODUCTION

PART 1

TA 70/97

MOTORWAYS. INTRODUCTION

SUMMARY

This Advice Note provides a general introduction to motorway communications, covering their purpose and a short history and summary of provision.

INSTRUCTIONS FOR USE

This is a new document to be inserted into the Manual.

1. Insert TA 70/97 into Volume 9 Section 2.
2. Archive this sheet as appropriate.

Note: A quarterly index with a full set of Volume Contents Pages is available separately from the Stationery Office Ltd.



THE HIGHWAYS AGENCY



THE SCOTTISH OFFICE DEVELOPMENT DEPARTMENT



**THE WELSH OFFICE
Y SWYDDFA GYMREIG**



**THE DEPARTMENT OF THE ENVIRONMENT FOR
NORTHERN IRELAND**

Introduction - Motorways

<p>Summary: This Advice Note provides a general introduction to motorway communications, covering their purpose and a short history and summary of provision.</p>

REGISTRATION OF AMENDMENTS

Amend No	Page No	Signature & Date of incorporation of amendments	Amend No	Page No	Signature & Date of incorporation of amendments

REGISTRATION OF AMENDMENTS

Amend No	Page No	Signature & Date of incorporation of amendments	Amend No	Page No	Signature & Date of incorporation of amendments

**VOLUME 9 NETWORK - TRAFFIC
CONTROL AND
COMMUNICATIONS
SECTION 2 INTRODUCTION**

PART 1

TA 70/97

MOTORWAYS. INTRODUCTION

Contents

Chapter

1. Introduction
2. References
3. Enquiries

1. INTRODUCTION

General

1.1 This Advice Note provides a general introduction to motorway communications, covering:

- (i) the purpose of motorway communications; and
- (ii) a short history and summary of provision.

Scope

1.2 This Advice note is applicable to the understanding of the development of motorway communications leading to the existing National Motorway Communications Systems.

1.3 The specific requirements for each Overseeing Organisation are contained in the relevant Annex to this Advice Note. They are as follows:

Annex A for England;

Annex B for Scotland;

Annex C for Wales;

Annex D for Northern Ireland.

1.4 This Advice Note is intended to be used by Overseeing Organisation staff, their consultants, Agents and maintenance contractors.

Related Standards and Advice Notes

1.5 The following Technical Directives are of relevance:

TD 45 : Motorway Incident Detection and Automatic Signalling (MIDAS)

TD 46 : Motorway Signalling

TD 47 : Motorway Loop Detectors

TD 48 : Motorway Closed Circuit Television System

1.6. The following Advice Notes are of relevance:

TA 71 : Design and Implementation (Overview)

TA 72 : National Motorway Communications Systems

TA 73 : Motorway Emergency Telephones

TA 74 : Motorway Signalling

TA 75 : Motorway Transmission

TA 76 : Motorway Control Office

TA 77 : Motorway Infrastructure Design

Implementation

1.7 This Advice Note is for background information only.

2. REFERENCES

1. Design Manual for Roads and Bridges (DMRB): Stationery Office Ltd

TD 45 : Motorway Incident Detection and Automatic Signalling (MIDAS) (DMRB 9.1.2)

TD 46 : Motorway Signalling (DMRB 9.1.1)

TD 47 : Motorway Loop Detectors (DMRB 9.1.3)

TD 48 : Motorway Closed Circuit Television System (DMRB 9.1.5)

TA 71 : Design and Implementation (Overview) (DMRB 9.3.1)

TA 72 : National Motorway Communications Systems (DMRB 9.4.1)

TA 73 : Motorway Emergency Telephones (DMRB 9.4.2)

TA 74 : Motorway Signalling (DMRB 9.4.3)

TA 75 : Motorway Transmission (DMRB 9.4.4)

TA 76 : Motorway Control Office (DMRB 9.4.5)

TA 77 : Motorway Infrastructure Design (DMRB 9.5.1)

3. ENQUIRIES

Approval of this document for publication is given by the undersigned:

Director of Traffic Systems and Signing Division
Highways Agency
Tollgate House
Houlton Street
Bristol
BS2 9DJ

R EASTMAN
Director of Traffic Systems and
Signing Division

The Deputy Chief Engineer
The Scottish Office Development Department
Roads Directorate
New St Andrew's House
Edinburgh
EH 3TG

J INNES
Deputy Chief Engineer

The Director of Highways
Welsh Office
Y Swyddfa Gymreig
Crown Buildings
Cathays Park
Cardiff
CF1 3NQ

K THOMAS
Director of Highways

Assistant Technical Director
Department of the Environment for
Northern Ireland
Roads Service
Clarence Court
10-18 Adelaide Street
Belfast BT2 8GB

D O'HAGAN
Assistant Technical Director

All technical enquiries or comments on this document should be sent in writing as appropriate to the above.

**VOLUME 9 NETWORK - TRAFFIC
CONTROL AND
COMMUNICATIONS**
SECTION 2 INTRODUCTION

PART 1

TA 70/97 Annex A (England only)

MOTORWAYS. INTRODUCTION

Contents

Chapter

1. Introduction
2. The Purpose of Motorway Communications
3. The Growth of Motorway Communications
4. Overview of Motorway Communications
5. Glossary
6. References

A1. INTRODUCTION

A1.1 General

1. This Annex is for the specific requirement of motorway communications in England.

DMRB Structure

2. Section 1 of Volume 9 of the Design Manual for Roads and Bridges (DMRB) contains Technical Directives (TD) which detail the Standards of Provision.

3. Section 2 onwards contains Technical Advice (TA) Notes which reflect current practice in the field of motorway communications and control.

Design Loop

4. Figure A1.1a shows the 'Design Loop' illustrating the general sequence in the iterative design process, which starts with the design for emergency telephones and signals followed by transmission and Control Office designs. Last in the cycle is the design of the infrastructure that will be required to support all communications equipment and systems.

Glossary

5. A Glossary of Terms is given in Chapter A5.

Standard Drawings & Specifications

6. Standard MCX and MCY drawings and MCH and TR specifications are issued by the Highways Agency (HA).

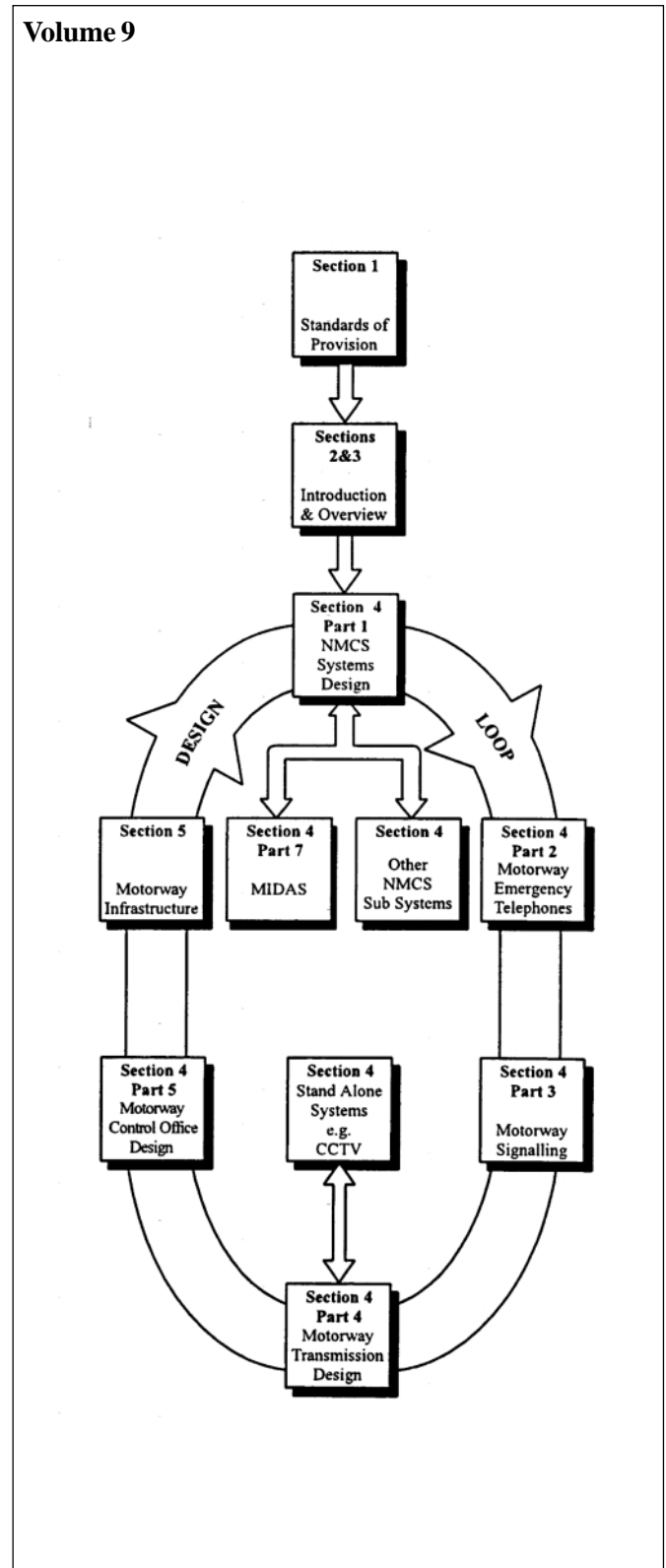

Figure A1.1a Structure of Volume 9 of the Design Manual for Roads ad Bridges

A2. THE PURPOSE OF MOTORWAY COMMUNICATIONS

A2.1 Overview

1. The purpose of motorway communications is to improve the safety of the travelling public on motorways and reduce delays through better management of the motorway network. This is achieved by:

- (i) Enabling motorists to call for assistance in case of emergency, breakdown or accident by using roadside emergency telephones directly connected to the police;
- (ii) Enabling the police to warn motorists of hazards ahead by setting signals and signs.

2. Developments in technology have resulted in further facilities, such as Motorway Incident Detection and Automatic Signalling (MIDAS), Closed Circuit Television (CCTV) monitoring, Message Signs for driver information, and meteorological detection systems being available to assist the police in their management of the motorway network.

A3. THE GROWTH OF MOTORWAY COMMUNICATIONS

A3.1 Introduction

1. The following paragraphs contain the historical background to, and a description of, motorway communications.

A3.2 Early Telephones

1. Since the opening of the Preston by-pass (M6) in 1958, the scope of motorway communications has increased with the development of the motorway network. The telephones installed were designed and operated by the Post Office. They continued in use on motorways throughout the country until the early 1980s.

2. In 1966 the Ministry of Transport (MOT) started to install a telephone system, which became known as the Phase 1 Telephone System. Several motorways still have Phase 1 telephones installed, however most are now equipped with more modern systems.

3. Phase 1 telephones have sometimes been used in the interim between the opening of a new motorway and the commissioning of the full telephone system. This approach is no longer recommended and the provision of the motorway communications equipment and associated infrastructure is now normally programmed as part of the main construction contract.

4. It is necessary for the emergency telephones to have a direct connection to the Police responsible for patrolling the particular section of motorway. Initially, telephones were connected to the local police station. Police forces operate a Control Office (CO) which is normally located at the county police headquarters. Motorway telephones and signals are now controlled from the CO.

A3.3 Development of Motorway Signals

1. The standard post mounted matrix signal, shown in Figure A3.3a, is used on the majority of motorways. Trials of signalling systems which took place in the 1960s resulted in the adoption of this standard design. Matrix signals are used to display speed restrictions, lane restrictions, lane divert arrows, 'Fog' warnings and the 'End' message.

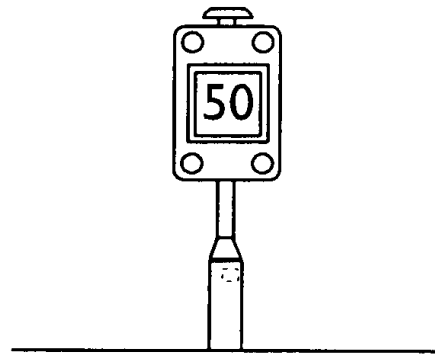

Figure A3.3a Post Mounted Matrix Signal

2. Until matrix signalling became commonplace, Motorwarn Signals (that legally represented a 30mph limit) were installed on motorways. These consisted of two vertically mounted flashing amber lanterns powered by batteries. They were activated locally by police patrols using a radar gun. Motorwarn Signals still exist on some remote motorways, but their provision is now no longer recommended.

A3.4 NMCS1

1. A National Motorway Communications System (NMCS1) was developed by the Ministry of Transport (MOT) and its successor, the Department of the Environment (DoE), following the success of the matrix signal.

2. NMCS1 controls a large number of telephones and signals using computers known as Central Processors.

3. The motorway network was initially covered by four Central Processors (CP), with each CP connected to a maximum of six Control Offices (CO). Control Offices were connected, via the relevant Central Processor, to equipment known as Responders. The Responders were in turn connected to the matrix signals and telephones.

4. The telephone system that was supported by NMCS1 became known as the Phase 2 Telephone System to distinguish it from the earlier Phase 1 Telephone System.

5. By the late 1970s, the Department of Transport (DOT) decided that the expansion of the motorway network would lead to a requirement for further computing facilities. National computer centres were built, in 1980 at Coleshill and in 1985 at Westhoughton. A national transmission network linking COs and CPs using a cable network was consolidated during this period. COs connected to the original CPs were gradually transferred to Coleshill and Westhoughton. However, the CP at Perry Bar remained in control of West Midlands communications until it was superseded in 1992 by a second generation National Communications Systems (NMCS2).

6. The upgrading of central processors corresponded with the replacement of computers in Control Offices. In 1984, the DOT began to install Personal Computers (PC) as replacements for the original signal setting equipment. These PCs give the user an interface to NMCS1 which provides an interactive graphical picture of the motorway, signals and telephones. In 1989 an updated PC was introduced giving a wider scope for additional facilities.

A3.5 NMCS2

Development

1. During the 1980s, computer and communications technology advanced at a rapid rate. NMCS1 was quickly becoming outdated and expensive to maintain. A new communications system design based upon international communications standards was developed by the DOT; this is known as the National Motorway Communications System 2 (NMCS2).

2. The first NMCS2 systems were installed in 1988 around the M25. They are controlled from police Control Offices at Chigwell, Welwyn, Heston and Godstone. They were followed in 1992 by systems in Greater Manchester and the West Midlands. A phased programme to upgrade all COs to a standard NMCS2 system is being implemented.

3. The Coleshill and Westhoughton Computer Centres provide a central logging facility for NMCS1 and NMCS2. This provides statistical data for

maintenance and planning purposes.

Capabilities

4. NMCS2 has the following advantages over previous systems:

- (i) support of more diverse equipment;
- (ii) more self testing resulting in fewer operational failures;
- (iii) improved transmission performance;
- (iv) greater capability for automatic operation;
- (v) minimal need for expensive Private Wire and longitudinal circuits;
- (vi) greater use of national and international equipment, communications and software standards.

5. As a result, NMCS2 reduces the cost of motorway communications and provides a better foundation for long term growth.

6. NMCS2 Systems are connected together by a national network of Regional Communications Controllers (RCCs) which transmit messages between COs and central logging facilities.

Control Office Base System

7. NMCS2 is based around Control Offices manned by the police. Each CO has its own computer known as a Control Office Base System (COBS). The COBS is connected to the system operators through Operator Interfaces (OIF), to the telephone system and via a Local Area Network (LAN), to the Subsystems which drive such functions as signal setting, incident detection and data collection at the equipment sited on the motorway.

Telephone System

8. The NMCS2 Telephone System is known as the Phase 3 Telephone System.

Outstation Equipment

9. There are two main types of NMCS2 outstation equipment:

- (i) Transponders which are used to control devices such as signals;

(ii) Telephone Responders for the support of the telephone system. A Telephone Responder is a roadside telephone exchange.

NMCS2/NMCS1 Compatibility

10. The technology employed by NMCS2 is radically different to that of NMCS1. There is very little interchangeability between components of the two systems. However, equipment has been developed to allow NMCS2 signalling equipment to operate within an existing NMCS1 Control Office Area; this is the 21-bit Transponder.

A3.6 Enhanced Signalling

1. In 1989 the DOT issued a White Paper entitled 'Roads for Prosperity' which proposed the widening of many of the country's motorways to four lanes. An alternative to gantry signalling, using standard matrix signals, on four lane motorways was required. A trial of new signals that provide greater driver information at a lower capital cost began in late 1991 on the south west quadrant of the M25.

2. The new signal is called a Motorway Signal Mark 2 (MS2). This comprises two elements:

- (i) *Enhanced Matrix Indicator (EMI)* - larger than the standard matrix signal and capable of displaying lane restrictions (using 'wickets') for up to 4 lanes.
- (ii) *Enhanced Message Sign (EMS)* - a variable message sign with 2 rows of 12 characters.

3. MS2 are mounted on cantilever structures sited on the verge to the rear of the hard shoulder. The EMS is mounted on the nearside of the EMI, as shown in Figure A3.6a.

4. EMS are also mounted on gantries which are equipped with matrix signals. Figure A3.6b shows a gantry equipped with EMS and matrix signals.

5. Motorways with four lanes are now provided with gantry signalling as standard. MS2 can be provided on 3 lane motorways, and exceptionally on 2 lane motorways. Refer to TD 46 : Motorway Signalling for details.

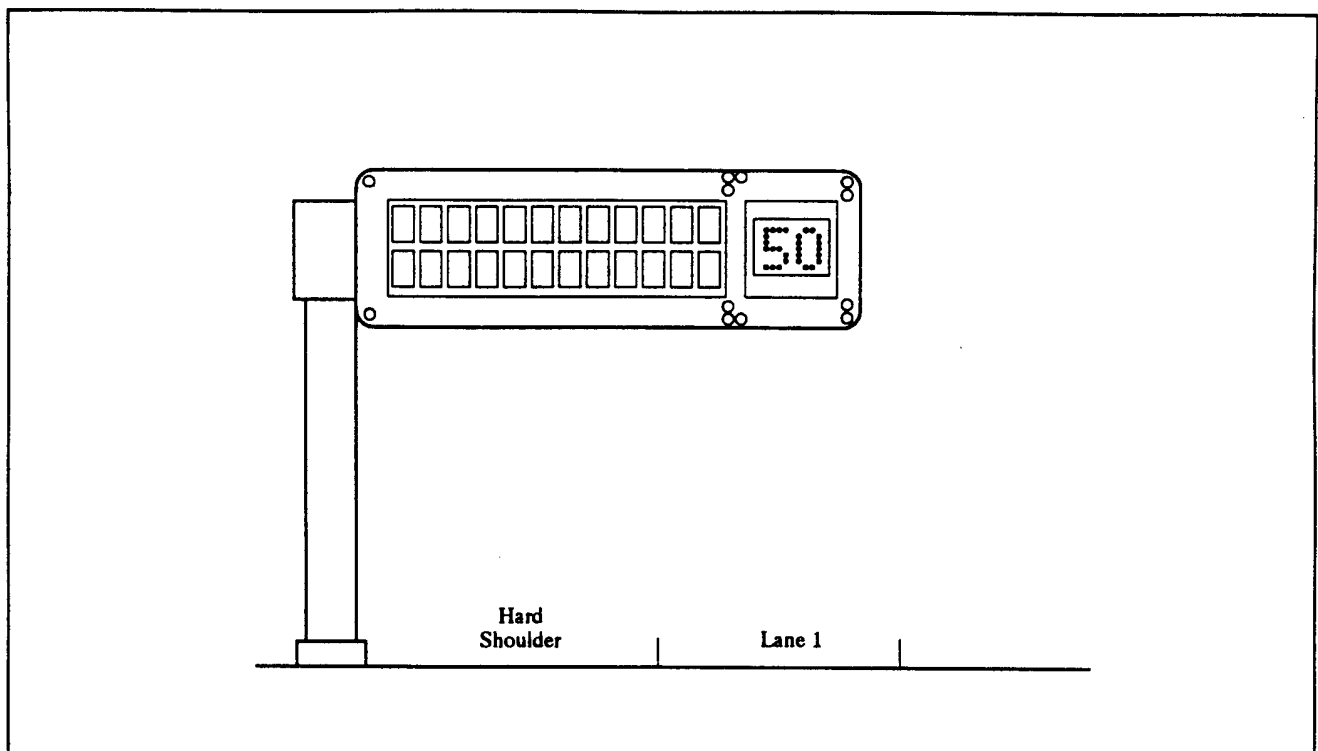

Figure A3.6a Motorway Signal Mark 2

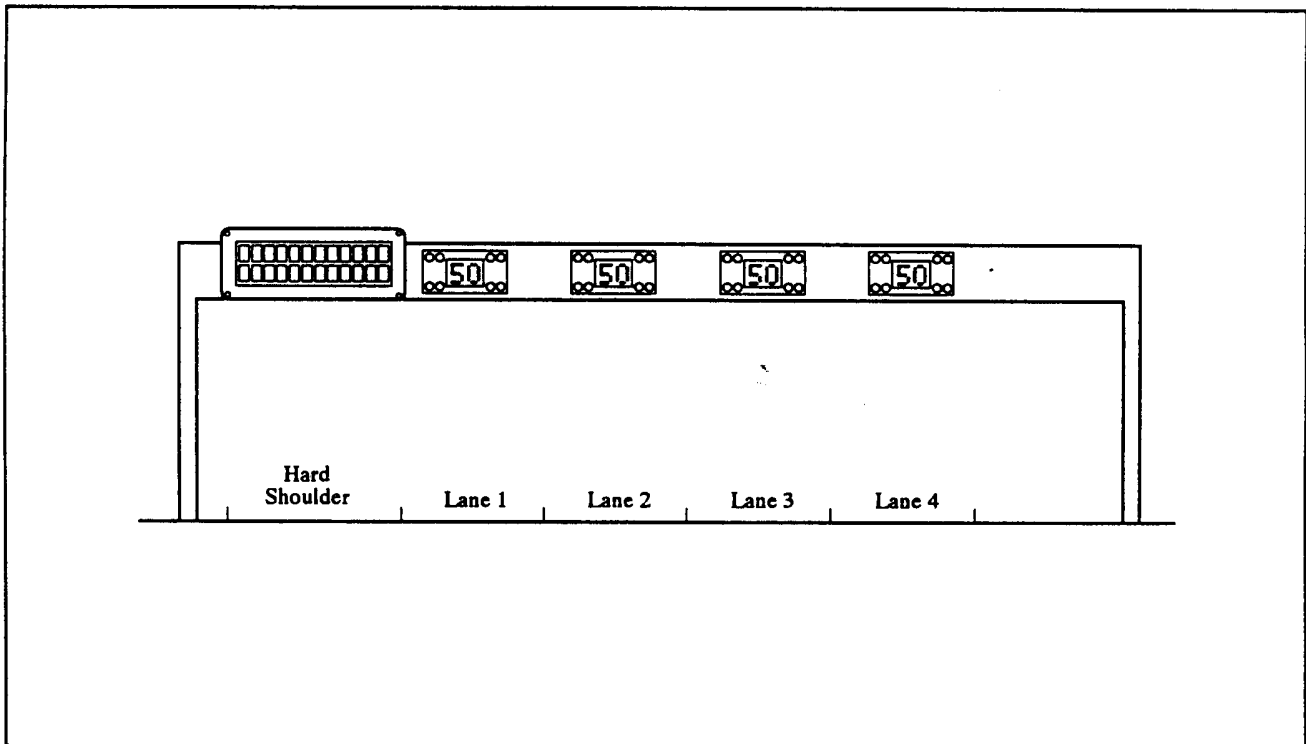

Figure A3.6b Gantry Mounted Lane Signals with EMS

A3.7 Motorway Incident Detection and Automatic Signalling (MIDAS)

1. MIDAS has been developed to make the signalling system more responsive to traffic conditions. Inductive loops are installed in the road surface at nominal 500m intervals to detect the movement of traffic. A prime aim of MIDAS is to protect the back of traffic queues, which have formed or are about to form, by automatically setting suitable signals to warn approaching traffic. When traffic flow returns to free flowing conditions the signal settings are cancelled.
2. MIDAS is also an integral part of the Controlled Motorway Pilot Scheme where it is used in conjunction with Controlled Motorway Indicators (CMI) and Enforcement Equipment.
3. MIDAS is a subsystem of NMCS2.
4. Where MIDAS Loop Detectors are to be installed on motorways constructed using porous asphalt, advice from the Highways Agency should be sought at an early stage. The material used to seal the slots into which loops are installed will introduce an impervious barrier into the porous asphalt layer.

A3.8 Further Developments

1. Due to the changes in motorway conditions caused by the increase in traffic, the following developments are being evaluated for future use:
 - (i) Ramp Metering to control traffic entering sections of very heavily used motorways by operating traffic lights at entry points. This should assist the flow through the merge and reduce the associated loss of capacity.
 - (ii) Meteorological Systems, such as fog and ice detection systems;
 - (iii) Driver Information Systems to display information regarding diversions, roadworks and reasons for restrictions;
 - (iv) Controlled Motorway Pilot Scheme in which the enforcement of mandatory variable speed limits is being trialled as a means to improve the flow of traffic during congested periods.

A4. OVERVIEW OF MOTORWAY COMMUNICATIONS

A4.1 Introduction

1. This chapter describes:
 - (i) Motorway Emergency Telephones;
 - (ii) Motorway Signals;
 - (iii) Infrastructure (cables and hardware);
 - (iv) Transmission Network;
 - (v) Control Offices;
 - (vi) NMCS1;
 - (vii) Other Facilities (Stand Alone Control, Variable Message Signs);
 - (viii) NMCS2.

A4.2 Motorway Emergency Telephones

Provision

1. Motorway emergency telephones are normally installed at intervals of $1.5\text{km} \pm 10\%$ (1km intervals on 4 lane motorways) on the verge adjacent to the hard shoulders. Extra telephones are provided, where necessary, to eliminate the need for stranded motorists to cross slip roads or discontinuities in the hard shoulder. Telephones are generally provided as a pair opposite each other on either side of the motorway.
2. The direction in which to travel to the nearest, safe to reach, telephone is shown by an arrow on the marker posts.
3. Motorway emergency telephones are connected to a police Control Office (CO) via the cabling infrastructure.
4. The current standard telephone system is the Phase 3 Telephone System.

Phase 1 Telephone Systems

5. The Phase 1 Telephone System is simple but employs dated technology. Only a few systems remain in operation, on short or remote sections of motorway.
6. Up to 16 telephones are grouped and connected to an answering panel in the CO by a cable installed specifically for the group. Only one call can be dealt with at a time.

Phase 2 Telephone System (NMCS1)

7. Phase 2 systems operate under the control of NMCS1.
8. In a Phase 2 System up to 8 telephones are connected to a roadside telephone exchange known as a Responder. A Responder may also control signals.
9. A Phase 2 system will often cover the whole of a CO Area, though in some cases other systems are present on part of the network. Up to 4 calls can be dealt with simultaneously.

Phase 3 Telephone System (NMCS2)

10. Phase 3 Systems operate under the control of NMCS2.
11. In a Phase 3 Telephone System up to 12 (exceptionally up to 18) telephones are connected to a Telephone Responder. Up to 6 calls can be dealt with simultaneously. An NMCS2 Telephone Responder controls telephones only.

Other Systems

12. Several other methods of connecting telephones to the CO are, or have been, used. These include dedicated cables provided by private operators, dedicated telephone lines and direct cabling. These methods are most likely to be used on non-trunk motorways and for All Purpose Trunk Road telephone schemes.

All Purpose Trunk Road Telephones

12. The provision of telephones on All Purpose Trunk Roads (APTR) should be in accordance with the criteria set in current standards.

13. Liaison with, and approval of, the Highways Agency are necessary where the use of NMCS infrastructure to provide telephones on APTRs is being considered.

Further Information

14. Further information on telephone siting and infrastructure is contained in TA 73 : Motorway Emergency Telephones.

A4.3 Motorway Signals

Overview

1. The types of motorway signals currently in use are:
 - (i) Motorwarn Signals;
 - (ii) Post Mounted Matrix Signals;
 - (iii) Cantilever Mounted Signals;
 - (iv) Gantry Mounted Signals.
2. Standards of provision for motorway signals are defined in TD 46 : Motorway Signalling.

Motorwarn Signals

3. A motorwarn signal comprises two amber lanterns, one mounted vertically above the other, on a backboard. The amber lanterns flash alternately.
4. Motorwarn signals are verge mounted and when activated denote a 30mph speed restriction.
5. New Motorwarn signals are no longer provided.

Post Mounted Matrix Signals

6. Post mounted Matrix Signals (MS) are used on carriageways of 3 lanes or less, and on some sections with 4 lanes which include a crawler lane. They are situated in central reservations or on right hand verges. This type of motorway signal can display speed restrictions, lane restrictions (using 'wicket' symbols) and fog warnings that apply to all carriageway lanes. Post Mounted Matrix Signals are spaced at approximately 3km intervals between junctions. Additional signals are provided at junctions and interchanges.

7. Entry slip road signals is the name given to a pair of post mounted MS provided at the start of entry slip roads in certain conditions. They warn of restrictions in force on the main carriageway and can be used to close the slip road.

8. Post Mounted MS displays are accompanied by amber lanterns positioned in each corner of the signal indicator. The amber lanterns flash alternately in horizontal pairs to draw attention to a restriction set on the MS. Post mounted MS situated at motorway entrances also contain four red lanterns adjacent to the amber lanterns. The red lanterns flash alternately in vertical pairs with an all lanes closed wicket aspect to provide a 'stop' signal.

Cantilever Mounted Signals

9. A Motorway Signal Mark 2 (MS2) comprises an Enhanced Matrix Indicator (EMI) and an Enhanced Message Sign (EMS) mounted on a cantilever structure. The MS2 provides instructions and information to motorists about speed and lane restrictions. Cantilevers are mounted on the verge adjacent to the hard shoulder.

10. The EMI comprises a matrix display larger than that on the MS, together with four amber lanterns, backing board and enclosure. For some applications, four red lanterns are also provided. The amber and red lanterns provide 'warning' and 'stop' signals respectively.

11. The EMI displays speed restriction and lane control information. Lane signalling is achieved by the use of 'wicket' symbols for up to four carriageway lanes. For carriageway closures, a 'wicket' symbol showing all lanes closed is displayed together with flashing red lanterns. The EMI display is set and monitored by an EMI Driver.

12. The EMS is a variable message sign comprising 2 rows of 12 characters. Each character is formed from a 5 x 7 matrix of display cells. An EMS, which is mounted on a display board with amber lanterns, has the capability to display a large number of legends to supplement, for example, speed restrictions shown on matrix signals, and to provide other traffic and travel information.

Gantry Mounted Signals

13. For separate lane signalling, generally at interchanges and on carriageways of 4 lanes or more, MS are mounted on gantries above each traffic lane.

14. Gantry signals can display fog warnings, speed restrictions, lane restrictions and lane diversions. The display applies only to the lane below each signal.

15. Gantry mounted MS also contain four red lanterns adjacent to the amber lanterns. The red lanterns flash alternately in vertical pairs with a red 'X' to provide a 'stop' signal.

16. EMS can also be mounted on gantries, to provide information to drivers in addition to the lane signalling provided by MS.

Signal Control Systems

17. NMCS1 can control matrix signals, and also Variable Message Signs (VMS) which have been specially configured. Signals are connected to a signal setting terminal at the CO via Responders. Each Responder may be connected to up to 8 matrix signals, and may also be connected to emergency telephones.

18. NMCS2 can control both MS and Enhanced Signalling. The CO communicates with the signals via Transponders (ST). Each ST has 4 ports each of which can control up to 30 indicators. Generally, only 3 out of the 4 ports are used.

19. A Stand Alone Control (SAC) system for EMS has been developed for use where NMCS2 is unavailable or it has not been upgraded to a Control Office Base System (COBS).

Further Information

20. Further information on signal siting, signal hardware and incorporating signalling designs into infrastructure design is contained in TA 74 : Motorway Signalling.

21. Further information on NMCS1 and NMCS2 designs is contained in TA 72 : National Motorway Communications Systems.

A4.4 Infrastructure

1. The motorway communications infrastructure is made up of equipment housed in standard cabinets which is connected by a network of standard cables. These items are usually bulk purchased by the Highways Agency (HA).

2. Historically, directly buried armoured cable has

been used. The current practice is to use non-armoured cables in a sealed and ducted infrastructure.

3. Armoured cables are available from the HA for use in maintaining an existing armoured cable network.

Communications Cables

4. The cable network comprises a cable (or cables) laid along the length of the motorway network - longitudinal cable. Longitudinal cables are installed in standard lengths which are jointed together to form a continuous network. Connections to equipment are made using local cables.

5. The main longitudinal copper cable currently in use is a non armoured 40 pair cable. In earlier installations an armoured 30 pair (NMCS2) or 20 pair (NMCS1) cable was installed.

6. The main longitudinal optical fibre cable is a non armoured 24 fibre cable. It is used for Pulse Code Modulation (PCM) data transmission and Closed Circuit Television (CCTV) transmission.

7. Quad cable is used for all NMCS2 local cabling to telephones, signals and other devices.

8. For NMCS1, cabling from Responders to telephones is 2 pair, and from Responders to signals, is 20 pair.

9. Coaxial cable is used for CCTV transmission over lengths of up to 1km from a Transmission Station or camera control cabinet.

Power Cables

10. Two standard sizes of cable, 10mm² and 25mm², are used. The specific requirements of a scheme may dictate the use of other sizes.

Cable Joint Enclosure

11. This is used to house the joints between adjacent lengths of non armoured communications cable and connections to local cables. It is an environmentally sealed unit which can be opened and reclosed without the need for any specialist tools or equipment. It is normally housed in an underground chamber.

Cabinet Type 600

12. This is a cabinet which is used for housing electronic equipment. It is weatherproof, constructed

from aluminium and comes complete with termination frame, power distribution unit and heaters. It has hinged doors on two, opposite, sides.

13. Cabinets Type 600 are also installed outside Transmission Stations where they are used to marshall copper cables and their links to Transmission Stations. These cabinets are known as Marshalling Cabinets.

Cabinet Type 609

14. This is a square pillar manufactured from galvanised steel. It has two internal compartments separated by a timber backing board. Each compartment is accessed by a lift off door.

15. Cabinets Type 609 are used for housing Electricity Supply Company Interfaces, Power Isolation and Distribution equipment and Private Wire interfaces.

16. Cabinets Type 609 are also used as an interface connection between an armoured and a non armoured cable network.

17. On a direct buried, armoured cable network, Cabinets Type 609 are used to house the joints between adjacent lengths of longitudinal cable and connections to local cables.

18. Longitudinal cables are jointed in one compartment - the 'main side' whilst local cables are terminated in the other compartment - the 'local side'.

Cabinet Type 617

19. This is similar in construction to a Cabinet Type 600 and is used as either cabinet based Transmission Station or for Phase 1 Telephone Bridging Units.

Cabinet Type 620

20. This is similar in construction to a Cabinet Type 600 and is a special cabinet used for an interface to a public telecommunications network.

Box 615

21. This is a box which is fitted inside a Cabinet Type 609 to house cable terminations.

Cabinet Bases

22. All Cabinets Type 600, 609, 617 and 620 fit onto a standard base cast around a metal plate providing a standard holding down bolt arrangement (plinth 610) and skirt.

Cabinet Locks

23. Cabinet doors are secured with a standard T-key or an allen key depending upon the cabinet construction details.

24. Some cabinets have locks on them. Only authorised personnel are issued with keys.

Further Information

25. Further information on infrastructure, how to install it and how detailed design information should be presented is contained in TA 77 : Motorways.

A4.5 Transmission Network

Overview

1. The NMCS transmission network evolved to support NMCS1 equipment, based on a multipair copper cable network. As the network evolves to support more NMCS2 systems, the use of optical fibre cable and PCM system transmission equipment will become more widespread. The standard provision for longitudinal cable is for a 40 pair copper cable and an optical fibre cable with 24 fibres.

2. Speech and data communications in the NMCS is achieved by means of cables. The main cables are installed alongside the motorway, within the motorway boundary.

Transmission Stations

3. Transmission Stations are provided at motorway/ motorway interchanges and at a maximum spacing of 20 km along the motorway. They serve outstations (eg Responders and Transponders) up to 10km on either side. There are two types of Transmission Stations - Cabinet Type 617 and Building. For any given CO area, all connections between the motorway and the CO will normally be taken via one 'master' Transmission Station. This should be a building and sited near the geographical centre of the area.

National Network

4. The NMCS National Network supports NMCS1 data communications between COs and CPs. It also carries logging information from NMCS2 COs to Coleshill.

5. It utilises 12 channel Frequency Division Multiplexing (FDM) equipment known as the 'Carrier' system. The main network is in a figure of 8 with Coleshill at the centre. There are several sub-loops off the figure of 8 such as M25 and the North West loop. The network is organised such that there is dual routing capability between any two points on the network.

Local Network

6. 'Mini Carrier' equipment provides a method of multiplexing several telephone channels and sending them down a single audio pair.

7. It uses the same type of 12 channel FDM equipment as the main line Carrier system.

Optical Fibre Pulse Code Modulation (PCM) System

8. Where optical fibre longitudinal cable is installed, PCM systems are being progressively implemented to achieve an enhanced, digital transmission medium.

Telemetry System

9. The NMCS longitudinal cable network carries a cable and transmission fault monitoring and telemetry information system accessible by maintenance engineers via a laptop personal computer (PC). The information available includes NMCS1 CO fault listings, cable break identification, an engineering notice board, up to date Transmission Records indexes and a facility to download a transmission drawing to the PC. The PC is connected to the Telemetry system via a modem which is plugged into either a telemetry socket at a Transmission Station or via the Public Switched Telephone Network (PSTN).

Further Information

10. More information on transmission is contained in TA 75 : Motorway Transmission.

A4.6 Control Offices

Overview

1. The Control Office (CO) is the operational centre for motorway communications. From the CO, the Police monitor and control motorway traffic within a geographical area (usually defined by county boundaries). The CO location varies from being within a force headquarters building to being a dedicated Motorway Control Centre. It may be adjacent to the

motorway network or some miles from the motorway. The motorway communications links to the motorway are either via dedicated cable, private wires or a microwave radio link.

2. The CO has two main parts:

- (i) The Control Room where the operators answer telephone calls, set signals and monitor CCTV pictures where available;
- (ii) The Equipment Room which houses the NMCS1 equipment and/or the NMCS2 COBS and engineers terminal. There is likely to be a rack of transmission equipment, the termination points for incoming circuits, and CCTV equipment.

Control Room

3. The layout of the Control Room is usually dictated by police requirements, operating procedures and space. Many have been designed to cope with NMCS1 layouts - up to 4 telephone answering positions, usually 2 signal setting positions and a wall mounted mimic diagram showing the county motorway network. In NMCS1 COs an active mimic with lamps that illuminate to show when a signal is set is provided.

4. The installation of NMCS2 and/or CCTV may coincide with a redesign or move of the Control Room. An NMCS2 CO may have up to 6 signal setting terminals and 6 Telephone Answering Panels, though some may be combined. It should be noted that the provision of an active mimic diagram within an NMCS2 CO is not a requirement of the Highways Agency. However, passive maps, refurbished NMCS1 mimics, or new mimics may be provided with the agreement of the Highways Agency. Funding for some or all of this work may be required from the police.

5. The integration of CCTV control panels and positioning of monitors requires detailed consultation with the police.

Equipment Room

6. The space requirement for the original NMCS1 equipment was for a cabinet one metre square in plan. Subsequent additions to house NMCS1 PCs have doubled this. Previously, therefore, motorway communications equipment has been squeezed into small areas at some COs. When planning improvements it must be borne in mind that eventually full NMCS2 and CCTV systems may be installed.

Further Information

7. Further information on Control Offices is contained in TA 76 : Motorway Control Offices.

A4.7 NMCS1

Overview

1. NMCS1 is being systematically replaced by NMCS2 in England.
2. NMCS1 has three main components:
 - (i) Central Processors (CPs);
 - (ii) Control Office (CO) Processors;
 - (iii) Outstation Equipment.
3. NMCS1 systems are no longer installed, however, they are still supported by the Highways Agency. The full range of NMCS1 equipment is available from the Highways Agency maintenance stores.

Central Processors

4. There are two Central Processors (CPs) covering England and Wales:
 - (i) Coleshill CP303 covering Midlands, Southern England and South Wales;
 - (ii) Westhoughton CP305 covering Midlands and Northern England.
5. The CPs control the sequencing and setting of signals, switch and identify telephones, initiate outstation tests and provide operational logs. They are instructed by the CO to set and clear signals and to ring telephones. The CP alerts the CO of incoming telephone calls, signal settings and faults.

Control Offices

6. Local processing is done by minicomputers in COs. These are augmented by Personal Computers, which provide a menu driven interface. They have replaced Trend teletype terminals as the method of inputting signal setting proposals. The Trend equipment is retained to provide local hard copy records of signal setting activity.

7. Telephones are answered at separate Telephone Answering Panels. The CP identifies the calling telephone and switches it onto the next available line. If the link to the CP fails, a basic one line party system exists. This is known as Line 1 working.

8. NMCS1 COs have active mimic diagrams on which a bulb is illuminated when a signal is in operation. The mimic also has system fault lamp indicators.

Outstation Equipment

9. The main item of outstation equipment is the Responder. The maximum capacity of a Responder is 8 signals and 8 telephones.
10. There are limitations on the number of Responder addresses in a CO Area.
11. Where new equipment is installed within an area controlled by NMCS1, the equipment will be NMCS2 signal equipment and Phase 2 telephones operating within NMCS1, using a telephone only responder.

Further Information

12. Further information on NMCS1, NMCS2 design rules and NMCS1 to NMCS2 changeover is contained in TA 72 : National Motorway Communications Systems.

A4.8 Other Facilities

Stand Alone Control

1. Stand Alone Controllers (SAC) have been used to control VMS systems in both NMCS1 and NMCS2 environments; however they should be treated as exceptions. They are connected to COs by one of the following methods:
 - (i) Utilising spare pairs on the longitudinal cable network;
 - (ii) Dedicated cable, possibly connected to PW circuits;
 - (iii) PW circuits direct to equipment.
2. SAC have been provided to control Enhanced Message Signs (EMS) until the NMCS2 instations have been upgraded to COBS. The instation control terminal operates in a similar manner to a CO308.

Fixed Text Message Signs

3. Fixed Text Message Signs (FTMS) have been provided in a number of locations on the UK motorway network. They can be controlled automatically, by NMCS1, NMCS2 or by SAC. Visibility and clarity of message are essential. To this end only FTMS approved by the Highways Agency may be installed.

A4.9 NMCS2

Overview

1. NMCS2 is the second generation of UK motorway communications hardware and software. With the exception of the speech circuits, it is a digital data communications system. Unlike NMCS1 which was controlled by two national computing centres, NMCS2 is centred around a CO (the Instation). Each NMCS2 system covers a CO Area only. It has a main processor within the CO, the COBS which is connected to a data transmission path and a telephone transmission path. A high level block diagram, Figure A4.9a, shows the two transmission paths of an NMCS2 system.

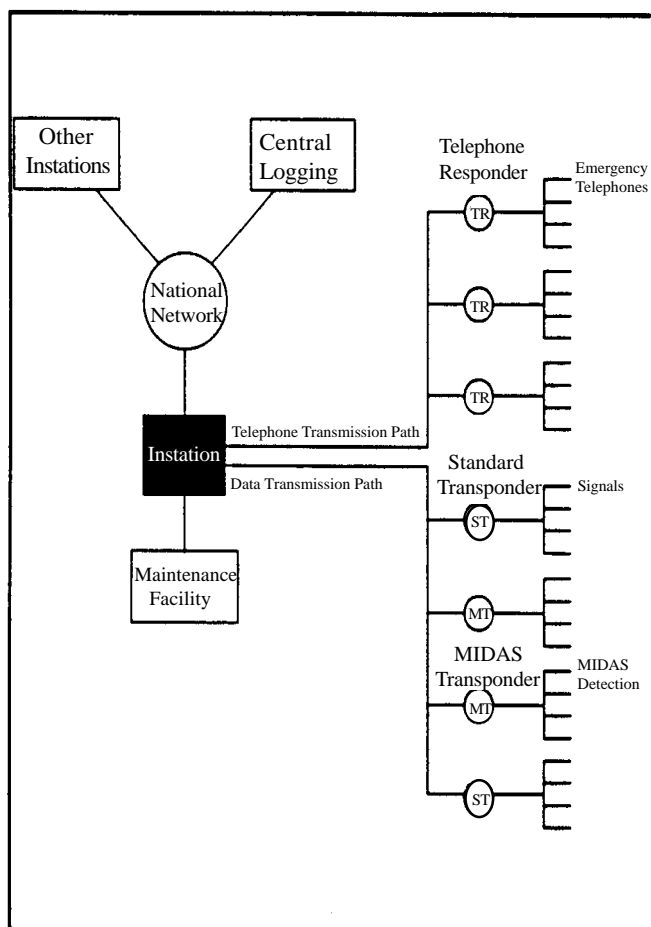

Figure A4.9a Block Diagram of NMCS2 System

2. The COBS is connected to a Local Area Network (LAN) within the CO that allows data Subsystems for motorway devices such as signalling to be implemented. These data Subsystems communicate with site equipment through outstation devices known as Transponders (ST) via the data transmission path.

3. The COBS connects the operators at the CO to the roadside telephones by controlling the telephone transmission path. The telephones themselves are connected to the Telephone Responder.

4. The NMCS2 CO is connected to other NMCS COs, and the National Network, via Regional Communications Controllers (RCC). This allows communications between COs, and the central logging of activity.

NMCS2 Documentation

5. The documentation describing and specifying NMCS2 is arranged in a hierarchical structure. At the top of the hierarchy is MCH 1616 NMCS2 Guide to Documentation. All NMCS2 designers should start with this document.

Control Office Base System (COBS)

6. COBS comprises all the standard components of an NMCS2 data system which are located within the CO. This includes:

- (i) The main processor;
- (ii) The Operator Interface (OIF);
- (iii) Connections to the CO LAN, the telephone system and the data system.

Control Office Base System (COBS)

7. The main elements of an NMCS2 telephone system (Phase 3 Telephone System) are:

- (i) A telephone instation, which is a desk in the CO, where an operator is permanently available to handle calls;
- (ii) Up to 6 telephone circuits throughout the CO area;
- (iii) Roadside 'mini-exchanges' known as Telephone Responders;

- (iv) Routing devices known as Sector Interface Equipment;
 - (v) The roadside telephones themselves.
8. The telephone instation comprises two main parts: a Telephone Line Controller (TLC) and an Operator Control Panel (OCP) for each telephone circuit. A third element, known as the Inter Panel Link Unit (IPLU), will normally connect all the TLCs together to enable calls to be transferred from one position to another and to provide a common event logging function. The OCP can be combined with a Visual Display Unit (VDU), so that it can also display information relating to the data system.
9. The Telephone Responder provides the facility to connect any telephone to any circuit as required. This ensures that the capacity of the overall system can be utilised fully. Each Telephone Responder covers up to 5km or 12 telephones, 18 telephones in special circumstances.
10. The telephone circuits are switched back to the instation through Sector Interface Equipment. These devices are either Block Interfaces switching 'Blocks' of Telephone Responders within a 'Sector', or Sector Interfaces switching sectors back to the CO.

Data System

11. The non-telephone elements of NMCS2 are collectively known as the data system. NMCS2 provides a common data communications facility for a variety of equipment to function and be controlled from the CO.
12. There are four different data communication paths:
- (i) A 'packet switched' link between COs and the national network of RCCs;
 - (ii) A 'point to point' link from the COBS to the Local Communications Controller (LCC). This is known as a High-level Data Link Control (HDLC). The LCC is the interface between the outstation and instation equipment;
 - (iii) HDLC links from each of the LCC's four output ports to the Transponders that interface with the site equipment. These are known as 'multidrop' links. Each multidrop link can service up to 60 Transponders;

- (iv) RS485 links from the Transponders to the site equipment. Each of the Transponder's four output ports can service up to 30 devices;
- (v) Figure A4.9b is a block diagram of the NMCS2 data system between the Control Office and site equipment.

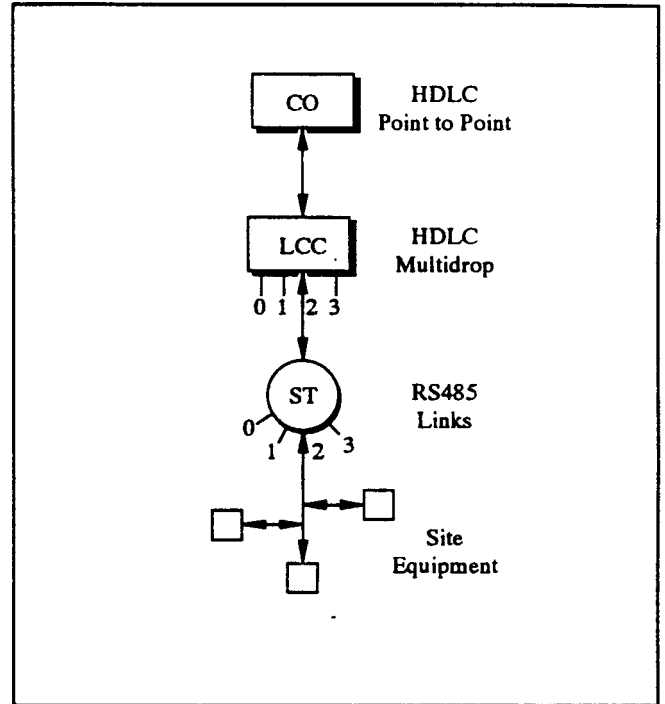

Figure A4.9b Data System Block Diagram

Subsystems

13. As well as the standard functions, all NMCS2 systems contain one or more Subsystems, which control a specific type of motorway device. A Subsystem is usually implemented on a separate processor, connected to the COBS via the LAN.
14. All NMCS2 systems have a Signals Subsystem which controls the signalling equipment.
15. Other Subsystems currently being considered are:
- (i) Message Sign (MS);
 - (ii) Lighting Control;
 - (iii) MIDAS;
 - (iv) Wall Mimic Control;
 - (v) Tunnels;
 - (vi) Fog.

NMCS1 to NMCS2 Changeover

16. NMCS1 to NMCS2 changeover may require modifications or renewal of much of a CO Area infrastructure.
17. A separate 21-bit Transponder can be installed at each ST site to allow NMCS2 signal site equipment to operate on NMCS1. It is possible to swap the 21-bit Transponder Interface Card for an ST Card with some makes of equipment. However, common practice is to replace the 21-bit Transponder with a new NMCS2 ST and return the 21-bit Transponder to Stores.
18. COs will in general be required to have both NMCS1 and NMCS2 equipment working in parallel until the changeover is completed.
19. TA 72 : National Motorway Communications Systems describes the stages necessary to achieve the changeover.

Further Information

20. Further information on NMCS2 is contained in TA 72 : National Motorway Communications Systems.

A5. GLOSSARY

Analogue Signal

An analogue signal is continuously variable within its limits for its duration.

Analogue Transmission

In analogue transmission the whole of the analogue signal is transmitted using an appropriate carrier.

Armoured Cable

A cable which incorporates a layer of steel wire wrapped helically around the cable to provide mechanical protection from damage. The armour wire is protected from moisture by a polyethylene sheath. The sheath is coated with graphite - this graphite coating is used when testing the integrity of the sheath.

Block

A section of carriageway between two Geographic addresses. If there could be multiple routes between the two addresses (eg clockwise and counter-clockwise on a circular route), a third Geographic Address is specified to identify a unique route.

Bulk Purchase

Standard items of motorway communications equipment are purchased by the Highways Agency in quantity. This ensures the equipment conforms to the relevant specifications, is available from several sources and benefits from economies of scale.

Cabinet Type 600

Standard motorway equipment cabinet, for use on motorway verges, to house equipment such as Standard Transponders, MIDAS Transponders, Responders, Sector Interfaces and Sector Blocks. Also used as a Marshalling Cabinet.

Cabinet Type 609

Standard motorway cable connection cabinet, for use on motorway verges, to house connection boxes for data, and also used to house (separately) electrical power supply distribution and isolation equipment.

Cabinet Type 617

Standard motorway cabinet, for use on motorway verges, to house transmission equipment.

Cabinet Type 620

Standard motorway cabinet, for use on motorway verges, to house interfacing to circuits provided by a Public Telecommunications Operator.

Cable joint Enclosure (CJE)

Environmentally sealed enclosure housed in underground chambers used to contain cable terminations, and in some cases, loading coils. CJE are available in the following types:

Type 15	Use	No. of Cables to be Accommodated	Comments
1	Longitudinal 40 pair joint	3 x 40 pair	Unloaded
2	Longitudinal 40 pair joint	3 x 40 pair	As 15-1, with additional module providing 22 circuits loaded at 22mH.
3	Longitudinal 40 pair joint	3 x 40 pair	As 15-1, with additional module providing 6 circuits loaded at 88mH.
4	Longitudinal 40 pair joint	3 x 40 pair	As 15-1, with additional module providing 28 circuits loaded as 22mH.
L	Local distribution	3 x 40 pair and 6 x quad	
RSI	Rural signal interface	4 x quad	
HFC	High frequency carrier joint	4 x carrier quad	
F	Optical Fibre Cables	3 x 24 fibre	

Note: Type RSI are housed in Cabinets Type 609

Cantilever

An overhead structure which extends from the verge. It has only one leg which is located in the verge. Used to support Enhanced Message Signs (EMS) and Enhanced Matrix Indicators (EMI).

Carrier

A signal comprising several individual signals multiplexed together. The carrier signal is at a higher frequency than the individual signals in analogue transmission and at a higher bit rate in digital transmission.

Central Processor (CP)

The main computer used in the Computer Centre, used to control, via the Control Offices, the motorway telephone and signals a number of COs. CPs in current use are:

- CP303 (Ferranti Argus) at Coleshill
- CP305 (Ferranti Argus) at Westhoughton

The CP is the central component in an NMCS1 system.

Closed Circuit Television (CCTV)

A system using remotely controlled television cameras to monitor traffic patterns at sites susceptible to traffic congestion such as tunnels junctions and interchanges. The images are transmitted from the camera to the Control Office (CO) over the fibre optic cable infrastructure.

Control Office (CO)

The Control Office (CO) is the location from where the Highways Agency's motorway communications equipment, for the motorways in a given Police Force Area, are controlled. The CO is used by the Police Authority for day-to-day control of motorway traffic. More than thirty Police Authorities are involved in operating the national system, each Police Authority being issued with a code of practice approved by the Association of Chief Police Officers, in order to standardise the use of motorway signals for each region.

Control Office Area

The area of influence and interest within a Control Office as defined by motorway devices with which it can communicate via the Local Communications Controller.

Control Office Area Base System (COBS)

That part of the installation which performs those functions which are common to all NMCS2 systems. Includes the Operator Interfaces (OI).

Control Room

The part of the Control Office where the operators answer telephone calls, set signals and, where available, monitor CCTV and operate other equipment. Sometimes shared with other Police Operations and equipment.

Digital Signal

A digital signal has discrete levels within its limits and these levels may be independent of preceding and succeeding levels.

Digital Transmission

The transmission of digital signals. The signal presented to the carrier is generally encoded and reconstructed at the receiving end.

Duct

A plastic pipe buried in the ground.

Electricity Supply Company Interface (EI)

An electrical power supply provided by an Electricity Supply Company at the motorway boundary.

EMI Driver

Data distribution unit Enhanced Matrix Indicator (EMI).

Enhanced Matrix Indicator (EMI)

A matrix signal which has additional aspects for use on four lane carriageways. EMI are mounted on Cantilevers only. When used in conjunction with an Enhanced Message Sign (EMS), it forms a Motorway Signal Mark 2 (MS2).

Enhanced Message Sign (EMS)

A sign which is used to display a variety of legends or messages. The legend or message is controlled from the installation. EMS has 2 rows of 12 characters. Can be mounted on a gantry or cantilever.

Enhanced Signalling

Generic term covering EMI and MS2.

Equipment Room

The part of the Control Office (CO) that houses the electronic equipment required to interface with the outstation devices and the operator interfaces within the Control Room.

Fixed Text Message Sign

A sign which can display more than one legend. The legends are changed by mechanical means such as rotating prisms. There are a fixed number of legends available; the legends themselves are also fixed.

Frequency Division Multiplexing (FDM)

An analogue transmission system where individual signals are multiplexed with a high frequency carrier to allow several signals to share a transmission circuit.

Gantry

An overhead structure which spans a carriageway having a leg in the verge and a leg in the central reserve (may span more than one carriageway and have more than 2 legs). Used to support signals and/or signs.

High-level Data Link Control (HDLC)

A protocol, at link level, which forms the basis of all inter-station communications on the NMCS2 data system, Closed Circuit Television (CCTV) system and the Regional Communications Controller (RCC) network. When each station communications link is set up, point to point or multidrop, the delivery, security and integrity of each frame of data is assured.

HDLC is the basis of a family of protocols which form the main data highway(s) for communication between Data Base Processor, Local Communications Controller, Regional Communications Controller and Transponders providing the packet message handling network.

Instation

Those parts of the National Motorway Communications System (NMCS) which are normally located within the Control Office. See also Outstation. Often referred to as the building which contains the Control Office and provides an office type environment for equipment sited at the instation.

Inter Panel Link Unit (IPLU)

An NMCS2 telephone instation unit used to co-ordinate the activities of the Telephone Link Controllers (TLC), such as call transfer and keeping each TLC aware of all other TLC relevant activity. It is the generator of the telephone logs.

Local Area Network (LAN)

Telecommunications terminology for a data communications network used to interconnect personal computers and equipment over a limited area.

Local Cabling

Cabling other than the longitudinal cabling, used to connect devices to the longitudinal cable or control equipment.

Local Communications Controller (LCC)

An NMCS2 data system message switching unit, the most significant CO area data system communications node. Sited at the most strategic point on the motorway network, it provides the downside on the Database Processor (DBP) - LCC level 2 link and the master on the four LCC-Transponder HDLC links.

Longitudinal Cable

The 40 pair copper and 24 fibre cables (two separate cables) running parallel to the motorway in the duct network, each pair and fibre is dedicated to a specific purpose. Historically 20 pair NMCS1 and 30 pair NMCS2 cables were direct buried. The 20/30 pair copper cables may be augmented by composite copper/optical fibre cables dedicated to CCTV or carrier circuits.

Longitudinal Circuit

A communications circuit running parallel to the motorway, contained in the longitudinal copper cable or the optical fibre cable.

Matrix Signal

A signal used for displaying traffic control legends to motorists. The legend (Aspect) is constructed from a matrix of lights. Each MS can display a predefined set of aspects only, such as 'Fog', 'End', speed restrictions, and lane restrictions using 'wickets'.

Message Sign

A generic term for signs which can display messages; this includes EMS, MS2 and FTMS.

Mimic Diagram

A large diagram which schematically represents the Control Office Area (COA) and indicates the status of the devices and systems in the COA.

Mini Carrier

Sub equipped high frequency Frequency Division Multiplex (FDM) carrier system used for local communications.

Motorway Device

Any outstation that interacts with its environment, serves as a source of information to be instation and/or is under the control of the instation.

Motorway Emergency Telephone

A telephone provided by the Highways Agency in the verge of motorways and all-purpose roads for use in the event of an incident or vehicle breakdown. Emergency telephones are linked, via the NMCS, to police Control Offices.

Motorway Incident Detection and Automatic Signalling (MIDAS)

A Control Office Base System (COBS) Subsystem which monitors traffic flow conditions and interacts with signal Subsystems to automatically set signals without

operator intervention. Signals are set when a queuing traffic is detected.

Motorway Signal Mark 2 (MS2)

A motorway signal comprising an Enhanced Matrix indicator (EMI) and an Enhanced Message Sign (EMS) mounted on a cantilever structure.

Multiplex

Individual signals mixed together into a single signal or carrier for transmission are said to be multiplexed, and applies to all types of signals. To recover the individual signals the carrier signal is demultiplexed.

National Motorway Communications System 1 (NMCS1)

A combined signalling and telephone system controlled from Regional and National central processors, installed up to 1988.

National Motorway Communications System 2 (NMCS2)

A system using locally based distributed processing to control telephones and signals, installed from 1988.

Operator Control Panel (OCP)

An NMCS2 unit, designed primarily for the telephone system to provide indicators, message display and keyed input to and from the operator. It also provides a means of input from the operator to the data system, in conjunction with the Operator Interface (OIF), using function keys to drive the menus and cursor keys to manipulate maps and text. Thirdly, it can provide a full text input when a QWERTY keyboard is plugged into the OCP.

Operator Interface (OIF)

The OIF provides a means of controlling the systems and can consist of an operator's control panel, a QWERTY keyboard and a visual display unit.

Optical Fibre Cable

Cable comprising glass fibres through which light is transmitted. The light is used as a medium for the transmission of signals. Optical fibre cables allow transmission over very long lengths due to their immunity from electromagnetic interference.

Outstation

Site installations outside computer centres and Control Offices, set up at convenient positions along the motorway to house communications equipment, such as Responders, distributors, signal controllers, signal

switches, connectors, terminal panels, and power supply units.

Packet Switch

Data network that divides messages into easily handled packages for transmission. Destination information is added to each package. The national transmission network linked by the Regional Communications Controllers (RCC) is a packet switched network.

Phase 1 Telephone System

A system of emergency telephones originally devised by the General Post Office (GPO) at the request of the, then, DTp, and sited along a motorway verge connected to a police control centre but not to the public telephone network. The Phase 1 system is completely independent of the NMCS.

Phase 2 Telephone System

The system of telephones installed along motorways as part of the first generation National Motorways Communications System, controlled by the Central Processor for call identification and switching.

Phase 3 Telephone System

The system of telephones installed along motorways as part of the second generation National Motorways Communications System (NMCS2).

Port

Telecommunications terminology for a physical interface or connection between equipment or between equipment and cables. A standard transponder has one High Level Data Link Connection (HDLC) port to the Local Communications Controller (LCC) and four RS485 ports.

Private Wire

A dedicated permanent circuit provided by a Public Telecommunications Operator between two locations.

Public Switched Telephone Network (PSTN)

PSTN is provided by a Public Telecommunications Operator (eg British Telecommunications Ltd, Mercury Communications Limited), ie a telephone connection accessed by the user dialling numbers.

Pulse Code Modulation (PCM) System

Pulse Code Modulation is a process of converting an analogue signal into a digital signal. A sample of the analogue signal is taken and equated to the nearest digital level. Each digital level is associated with a binary code. This code is transmitted instead of the

analogue signal. This process operates on an individual signal and does not create additional capacity. The analogue signals are sampled at 8KHz and produce 8-bit codes. This gives a single channel with a bit rate of 64,000 bits per second or 64Kbit/s.

PCM is commonly used to describe multi channel digital transmission systems. This is not totally correct as PCM is not a transmission system. PCM is generally used with Time Division Multiplexing (TDM) transmission systems.

Quad Cable

A 4 wire cable in which all the wires are twisted (laid) together, rather than in 2 pairs. This reduces cross pair interference where the pairs are used as the same channel.

Regional Communications Controller (RCC)

An NMCS message switching unit, and the national network communications network. The RCC is an NMCS item of equipment which provides the facility of linking a Control Office, to other communication centres and Control Offices.

Responder

An NMCS1 outstation which controls telephones and signals.

RS485

A data protocol (EIA RS485) and practice adopted for use by NMCS2 between the Standard Transponder and motorway devices.

The RS485 Multidrop Link is the lowest hierarchical level of transmission in an NMCS2 data system and provides the means, parameters and protocol of communication between Transponders and motorway devices. It allows the Transponder to control several devices at once or individual devices. However, individual devices can only transmit to the Transponder.

Transmission is half duplex, ie transmission in only one direction at once. Each link caters for up to 30 motorway devices. Each message comprises 5 characters of 8 data, 1 parity, 1 start and 1 stop bits. The characters represent address, command, data byte 1, data byte 2 and longitudinal parity.

Sector

An NMCS2 telephone system term. See Sector Switch and Sector Interface.

Sector Interface

An NMCS2 telephone system unit. Sited at the most strategic point in the motorway, the SI is the most significant telephone node in the Control Office area network. The SI provides, for the telephone system, the transmission system facility for common speech and data circuits. It comprises 4 ports which are themselves comprised of Sector Switches needing one Sector switch for each Telephone Line Controller the port serves. It provides an interface between the Telephone Line Controller and the lower order telephone switching stations.

Sector Switch

An NMCS2 telephone system unit, the next most significant telephone node after the Sector Interface. Sector Switches are the units that make up a sector interface. There is one Sector Switch for each telephone circuit. The Sector Switch, when used as a station in its own right, performs as an intermediate level between the Sector Interface and Responders.

Stand Alone Control (SAC)

A non NMCS2 system used to control and update Message Signs.

Standard Transponder (ST)

Standard Transponder is at the lowest hierarchical level within the Control Office Area. It interfaces to Local Communications Controller/HDLC links and provides a star point on the RS485 local links. It also provides some of the signal Subsystem functions and a post box service to other Subsystems. It controls up to 120 motorway devices.

Subsystem

A group of commands, communications messages and types of Motorway Devices which together implement a primary function of the system, eg Fog, Signals.

The Subsystem provides the format, sequence and information for the use of its facilities in NMCS2. Examples are as follows:

SIG	Signals
MSS	Message Signs Subsystem
FOG	Fog Detection
MIDAS	Motorway Incident Detection and Automatic Signalling

MET	Meteorological Monitoring (ie wind speed and direction, ice, etc)
LTG	Lighting Control

Telemetry System

Telecommunications terminology for the remote monitoring and control of equipment, devices and systems.

Telephone Answering Panel

A TAP is the instation element of the temporary telephone system. Telephone Bridging Units and Telephone Answering Units operate in pairs.

Telephone Bridging Unit (TBU)

The TBU is the outstation part of a temporary telephone system used on opened motorways before commissioning an NMCS1 or 2 system.

Telephone Line Controller (TLC)

An NMCS2 telephone system instation unit. The TLC links an Operator's Interface to the Inter Panel Link Unit and controls the outstation telephone status and switching on one of a set of parallel circuits serving all, or a selection of, Responders within a Control Office Area.

Telephone Responder

A motorway based mini telephone exchange controlling the connection of telephones with an NMCS2 Control Office.

21-bit Transponder

This item of equipment is a derivative of the Standard Transponder (ST), modified to allow communication with an NMCS1 Central Processor, to enable control of NMCS2 signals in an NMCS1 Control Office (CO) Area. The 21-bit Transponder translates and interprets messages received from NMCS1 and controls the signal accordingly. The term 21-bit is derived from the NMCS1 21 bit word length.

Transmission

Telecommunications terminology for the sending and receiving of signals.

Transmission Network

A network of cable and equipment which allows the sending and receiving of signals between devices and Control Offices.

Transmission Station

A Transmission station is an outstation unit provided to house telecommunication equipment required to allow successful communications between the Instation and Outstation Services. The TS are either buildings or cabinets Type 617 and are spaced at approximately 20km intervals within a Control Office area.

Variable Message Sign (VMS)

A sign which can display a number of defined legends or messages.

Visual Display Unit (VDU)

A VDU comprises a colour monitor for the presentation of active data system and telephone information superimposed on road layouts. It may be a component of the Operator's Interface provided for each Control Office operator position.

Wall Mimic Control

An NMCS2 Subsystem that controls mimic diagrams.

A6. REFERENCES

1. Design Manual for Roads and Bridges (DMRB): Stationery Office Ltd

TD 46 : Motorway Signalling (DMRB 9.1.1)

TA 71 : Design and Implementation (Overview) (DMRB: 9.3.1)

TA 72 : National Motorway Communications Systems (NMCS) (DMRB 9.4.1)

TA 73 : Motorway Emergency Telephones (DMRB 9.4.2)

TA 74 : Motorway Signalling (DMRB 9.4.3)

TA 75 : Motorway Transmission (DMRB 9.4.4)

TA 76 : Motorway Control Office (DMRB 9.4.5)

TA 77 : Motorway Infrastructure Design (DMRB 9.5.1)

2. MCH 1616 NMCS2 Guide to Documentation