



**THE HIGHWAYS AGENCY**

**BE13**



**THE SCOTTISH OFFICE DEVELOPMENT DEPARTMENT**



**THE WELSH OFFICE  
Y SWYDDFA GYMREIG**



**THE DEPARTMENT OF THE ENVIRONMENT  
FOR NORTHERN IRELAND**

# **Fatigue Risk in Bailey Bridges**

# TECHNICAL MEMORANDUM ( BRIDGES )

## Fatigue Risk in Bailey Bridges

1. The Military Engineering Experimental Establishment has drawn the Department's attention to the possibility of fatigue failure occurring in the main girder panels of Bailey Bridging when these are used in service for long periods. This arises because fatigue as a criteria was discounted in the original design on the grounds of the short life required from the bridge in its military role. A copy of the MEXE report is attached.
2. The most probable position for a fatigue crack to develop is at points of maximum stress in the tension cord at the sway brace slot as shown in the attached Sketch at 'A'. Occasionally the cracks shown at 'B' have been found under conditions of heavy shear.
3. The danger of a complete collapse as a result of fatigue cracking will depend on the make-up of the bridge. One crack in a "single-single" girder construction is much more dangerous than in multiple girder construction where a measure of "fail safe" is provided.
4. All highway authorities owning Bailey Bridging are therefore advised to observe the following precautions:-
  - 4.1 To arrange for an immediate inspection to be made of bridges in service and thereafter at regular intervals.
  - 4.2 If the bridge has been recently painted then the paint should be removed from the critical zones to ensure detection of cracks. Cracks are more readily discernible when the structure is under load and only those visible to the naked eye need cause concern.
  - 4.3 Whenever visible cracks are detected the panel should be taken out of service immediately. No attempt should be made to repair cracks by welding.
  - 4.4 Where the risk of complete collapse is revealed emergency action should be taken to relieve the bridge of load by road closure and by shoring.
  - 4.5 When any structure is dismantled the bridge panels should be carefully examined for cracks before repainting and stock piling for further use. Stored panels should be carefully examined before building into a bridge structure.
5. The foregoing precautions should also be observed when Bailey Bridging panels are used by a Contractor for Temporary Works.
6. Further information on fatigue in Bailey Bridges may be obtained by reference to a paper published by the British Welding Journal, April 1960 pages 272-280 ("Programmed Fatigue Testing of Full Sized Welded Steel Structural Assemblies" by J.G.Whitman and J.F.Alder).
7. This memorandum is also being circulated to the British Railways, London Transport and British Waterways Boards and Highway Authorities are requested to bring it to the attention of any other private bridge owner.

Bridges Engineering Division  
Ministry of Transport  
St. Christopher House  
Southwark Street  
London, S.E.1.  
8th April 1968

(L.R.Greenaway)  
Assistant Chief Engineer

## MILITARY ENGINEERING EXPERIMENTAL ESTABLISHMENT REPORT FATIGUE IN BAILEY BRIDGES

It is known that Bailey Bridges are being used in service for very long periods and the purpose of this note is to sound a warning on the possible dangers of fatigue failure of the main girder panels which may result if the original design of any particular Bailey Bridge did not take such long life into account.

The Bailey Bridge was designed to meet a military requirement where the lightness and transportability of the equipment was of paramount importance. The military load classification, therefore, represents the greatest loads that the structure can safely carry on short term considerations. Fatigue as a criterion in design was discounted on the grounds of the short life required from the bridge in its military role.

As a general statement it can be said that the danger of a fatigue failure will arise if the make-up of a Bailey Bridge was decided on the basis of the military load classification, and if the subsequent civilian loading approached this value for long periods. Even under such conditions, however, ten years or more have been known to elapse before fatigue cracks develop because the normal traffic spectrum includes a majority of light vehicles. The danger becomes more acute when local circumstances give rise to a larger proportion of vehicles which load the bridges to capacity, and this danger becomes particularly acute if the make-up of the bridge is designed for a low military class (e.g., Class 9), where common civil vehicles such as 3-ton lorries stress the bridge members to their "short life" limit.

Fatigue life in a bridge can be controlled through the level of live load stress and so any new design should be based on a stress level which will ensure an adequate life to meet the particular requirement. It is, therefore, recommended that for civilian use the make-up of the main girders of the Bailey Bridge are designed so that the stresses do not exceed the values laid down in British Standard 153, 1966 revision (Steel Girder Bridges) as given for British Standard 968 Steel (Case G).

If any existing bridge is found to be carry loads in excess of such recommendations, a very careful search should be made for the existence of fatigue cracks. The most probable position for a fatigue crack to develop is at points of maximum stress in the tension chord at the sway brace slot as shown in the attached Sketch at 'A'. Very occasionally the cracks shown at 'B' have been found under conditions of heavy shear. Examination for such cracks should be carried out some time after the application of any fresh coats of paint and are more readily discernible when the structure is under load. Only cracks visible to the naked eye need cause any concern - cracks less than 1/4" (6 mm) in length are, in fact, very fine, and not easy to see, but if they are found there may remain many years of life to the bridge. The rate of growth of such cracks, however, should be carefully watched and it is recommended that they are not allowed to exceed 1/2" (12 mm) in length - particularly if more than one crack is occurring as illustrated - before the component is taken out of use.

As the crack grows in length it becomes more easy to detect, and when it exceeds 1/2" (12 mm) in length and begins to open up, it is readily discernible. At this stage, however, the component will be getting dangerously near to the end of its fatigue life and immediate action should be taken. Naturally, the danger of complete collapse as a result of such cracks will depend on the make-up of the bridge. One crack in a single-single construction is much more dangerous than in a multiple construction where a fair measure of "fail safe" is provided. No attempt should be made to repair such cracks by welding.

Finally, it should be realised that fatigue is cumulative and no significant recovery takes place while the equipment is stored in an unstressed condition. When any structure is dismantled, therefore, the bridge panels should be carefully examined for this type of crack before repainting and stock-piling for further use. Also, existing stocks should be carefully examined before building into a structure where fatigue conditions would apply.

POSSIBLE LOCATIONS OF FATIGUE CRACKS

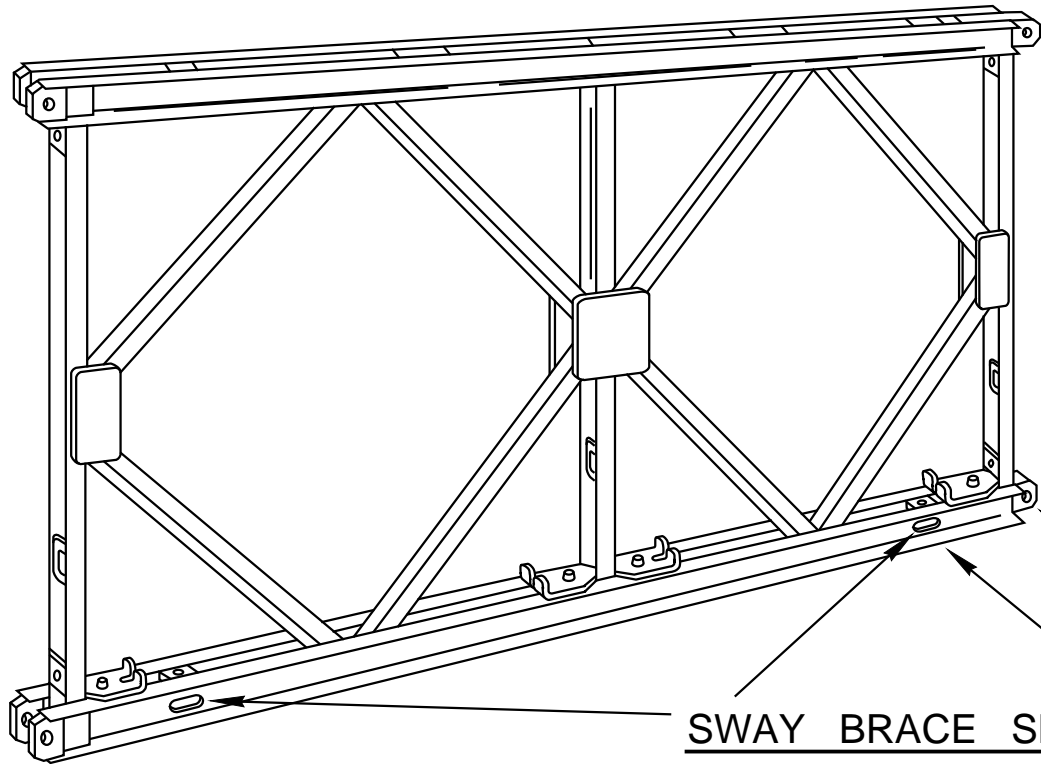

SWAY BRACE SLOTS

BAILEY PANEL

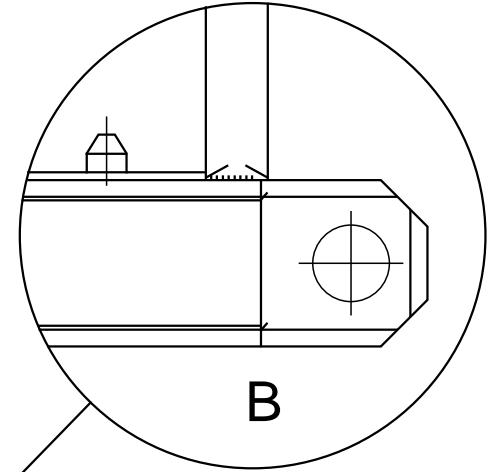

B

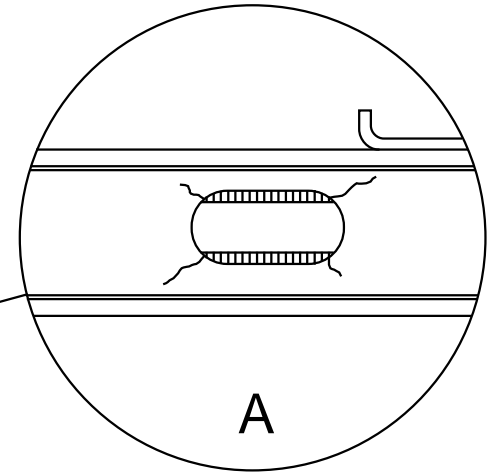

A

MEXE. SK. No. 39821