**VOLUME 2 HIGHWAY STRUCTURES:
DESIGN (SUB
STRUCTURES AND
SPECIAL STRUCTURES),
MATERIALS**

**SECTION 3 MATERIALS AND
COMPONENTS**

PART 4

BD 47/99

**WATERPROOFING AND SURFACING OF
CONCRETE BRIDGE DECKS**

SUMMARY

This Standard gives the requirements for the design materials and workmanship for the waterproofing and surfacing of the concrete decks of highway bridges and is to be read in conjunction with the Specification for Highway Works. It supersedes BD 47/94.

INSTRUCTIONS FOR USE

1. Remove BD 47/94 from Volume 2, Section 3, Part 4 of the DMRB, which is superseded by BD 47/99, and archive as appropriate.
2. Insert BD 47/99 into Volume 2, Sections 3, Part 4.
3. Archive this sheet at appropriate.

Note: A quarterly index with a full set of Volume Contents Pages is available separately from The Stationery Office Ltd.



THE HIGHWAYS AGENCY



**THE SCOTTISH EXECUTIVE DEVELOPMENT
DEPARTMENT**



**THE NATIONAL ASSEMBLY FOR WALES
CYNULLIAD CENEDLAETHOL CYMRU**



**DEPARTMENT OF THE ENVIRONMENT FOR
NORTHERN IRELAND**

Waterproofing and Surfacing of Concrete Bridge Decks

Summary:

This Standard gives the requirements for the design materials and workmanship for the waterproofing and surfacing of the concrete decks of highway bridges and is to be read in conjunction with the Specification for Highway Works. It supersedes BD 47/94.

REGISTRATION OF AMENDMENTS

Amend No	Page No	Signature & Date of incorporation of amendments	Amend No	Page No	Signature & Date of incorporation of amendments

REGISTRATION OF AMENDMENTS

Amend No	Page No	Signature & Date of incorporation of amendments	Amend No	Page No	Signature & Date of incorporation of amendments

**VOLUME 2 HIGHWAY STRUCTURES:
DESIGN (SUB
STRUCTURES AND
SPECIAL STRUCTURES),
MATERIALS**

**SECTION 3 MATERIALS AND
COMPONENTS**

PART 4

BD 47/99

**WATERPROOFING AND SURFACING OF
CONCRETE BRIDGE DECKS**

Contents

Chapter

1. Introduction
2. Scope
3. Definitions
4. Drainage
5. Detailing of Deck Waterproofing
6. Concrete Deck Construction
7. Waterproofing Systems
8. Installation and Workmanship
9. Protection of Waterproofing
10. Surfacing on Carriageways
11. Surfacing on Footways Central Reserves and Verges
12. References
13. Enquiries

Appendix A: Procedures to Enable the Use of
Waterproofing Systems in Highway
Contracts

Appendix B: Certification Test Requirements for
Waterproofing Systems on Concrete
Bridge Decks

Appendix C: Procedures and Requirements for
Certification Site Trials for Permitted
Waterproofing Systems

1. INTRODUCTION

General

1.1 The decks of highway bridges are protected to prevent surface water from coming into contact with the structure. This is achieved by the provision of adequate drainage and by waterproofing the upper surface of the deck. Such waterproofing has to be sufficiently robust to resist transient vehicular loading, maintain good adhesion to the deck and the surfacing, be resistant to de-icing salts and possess long term durability.

1.2 Bituminous road surfacing materials are not sufficiently waterproof to protect bridge decks. Satisfactory waterproofing is achieved by applying a membrane on to the structural deck.

1.3 This Standard updates BD 47/94 (DMRB 2.3.4) which superseded BE 27 (DMRB 2.3) which is now cancelled. It should be read in conjunction with BA 47 (DMRB 2.3.5) and the Specification for Highway Works (MCHW 1).

1.4 Except where a standard specified in this document implements or is technically equivalent to a Harmonised European Standard or to a European Standard adopted for use within the European Economic Area after 31 December 1985, any requirements for products or materials to comply with the specified standard shall be satisfied by compliance with

- i) a relevant standard or code of practice of a national standards institution or equivalent body of any member state of the European Economic Area
- or ii) any relevant international standard recognised in any member state of the European Economic Area
- or iii) a relevant technical specification acknowledged for use as a standard by a public authority of any member state of the European Economic Area
- or iv) traditional procedures of manufacture of a member state of the European Economic Area where these are the subject of a written technical description sufficiently detailed to permit assessment of the goods or materials for the use specified

provided that the proposed standard, code of practice, technical specification or technical description provides

in use levels of safety, suitability and fitness for purpose equivalent to those required by the specified standard in so far as they are not inconsistent with the 'Essential Requirements' of the Construction Products Directive (89/106/EEC).

1.5 Where reference is made to the British Board of Agrément (BBA) the equivalent assessment body in any member state of the European Economic Area will also be acceptable.

1.6 Where tests are carried out in other Member States these requirements shall be satisfied if the Test House is accredited in a member state of the European Economic Area in accordance with the relevant part of the EN 45000 series of standards for the tests carried out.

Certification and Registration Requirements

1.7 Waterproofing systems are required to have a BBA Roads and Bridges Agrément Certificate before they may be installed on concrete bridge decks constructed, improved, or maintained in compliance with the Specification for Highway Works (MCHW 1). Requirements are given in Appendices A, B, and C. In addition, waterproofing systems are required to be registered with the Overseeing Organisation. Departmental Registration is administered by the Highways Agency on behalf of all the Overseeing Organisations.

1.8 This Standard contains new Certification test requirements. New certificates will be required from 1 June 1998.

1.9 Waterproofing systems that have been granted Departmental Registration are listed in SA1 (MCHW 0.3.1). The details in the Advice Note are updated by the Overseeing Organisations on a regular basis.

Implementation

1.10 This Standard should be used forthwith on all schemes for the construction, improvement, and maintenance of trunk roads, including motorways, currently being prepared, provided that, in the opinion of the Overseeing Organisation, this would not result in significant additional expense or delay. Design Organisations should confirm its application to particular schemes with the Overseeing Organisation.

2. SCOPE

General

2.1 This Standard specifies the requirements for waterproofing and surfacing concrete bridge decks and shall apply generally to new works and where appropriate to the maintenance and repair of existing works. It describes the design and registration requirements for waterproofing systems for use on concrete decks of highway bridges.

2.2 The types of bridge decks covered by this Standard are described but the waterproofing of other parts of bridge structures (eg below ground surfaces, piers and abutments and other salt spray susceptible areas) are not included.

2.3 For the purpose of this Standard, concrete bridges are deemed to include accommodation bridges together with tunnels, box type underpasses, culverts and cattle creeps etc except when such structures are constructed by thrust boring or tunnel techniques where the external faces are inaccessible for the application of waterproofing. In such cases reference should be made to the appropriate Overseeing Organisation.

In the case of tunnels and box type underpasses where the bottom slab carries traffic and also where a ground slab is used in a traffic underpass, the slab carrying traffic shall be waterproofed and surfaced as a bridge deck.

2.4 The requirements for waterproofing the top slabs of concrete buried structures are included. For concrete pipes or curved arch sections reference should be made to Clauses 2004 and 2006 of the Specification (MCHW 1).

Steel Decks

2.5 Requirements for the waterproofing and surfacing of steel decks are not included in this Standard and the treatment of such decks shall be considered individually for each case using the most appropriate techniques available at the time and agreed with the Technical Approval Authority (TAA).

Footbridges

2.6 Requirements for the waterproofing and surfacing of footbridges are not included in this Standard and the treatment of such structures shall be considered individually for each case using the most appropriate techniques available at the time and agreed with the TAA.

Corrugated Steel Buried Structures

2.7 Requirements for the waterproofing of corrugated steel buried structures are given in BD 12 (DMRB 2.2).

Aqueducts

2.8 The waterproofing of aqueducts is not within the scope of this Standard, and the treatment of such structures shall be considered individually for each case using the most appropriate techniques available at the time and agreed with the TAA, except where the top of the aqueduct is over-slabbed and carries a highway, in which case the top slab is considered as a bridge deck.

3. DEFINITIONS

Waterproofing system

3.1 A material or combination of materials which form an impervious membrane, including where appropriate a protective layer, for ordered application to a bridge deck to protect it from the ingress of water and de-icing salts.

Permitted Waterproofing System (PWS)

3.2 A waterproofing system (proprietary or non-proprietary) which is in accordance with the requirements and conditions of this Standard.

Protective layer

3.3 Material forming part of a Permitted Waterproofing System laid on the waterproofing membrane to protect it from damage during construction.

Additional Protective Layer (APL)

3.4 Bituminous material complying with Clause 2003.4 of the Specification (MCHW 1) laid on specified areas of the complete waterproofing system to protect it from damage during construction, surfacing and resurfacing operations.

Surfacing

3.5 Road, footway, central reserve and verge wearing course or combination of wearing course and base course.

Sub-surface drainage

3.6 A system for draining water from within the surfacing.

Specification

3.7 Specification for Highway Works (MCHW 1).

4. DRAINAGE

Surface Water Drainage

4.1 Surface water shall be removed from the bridge deck by the provision of falls and suitable drainage outlets, continuous drainage channels etc. Advice on surface water drainage is given in BA 47 (DMRB 2.3.5).

and resistant to all commonly occurring chemical spillages. Drainage systems shall not contain details which are integral with structural elements. Drainage waters from bridge decks shall not be exhausted into the drainage layers behind abutments.

Sub-surface Drainage

4.2 Bituminous surfacing is porous and can retain surface water. Where the geometry of the deck or deck movement joints prevents this water from draining naturally through surface drainage, sub-surface drains shall be provided. Advice on sub-surface water drainage is given in BA 47 (DMRB 2.3.5).

Drainage of Service Bays and Ducts

4.3 All service bays shall have provision for drainage. Wherever possible service bays shall be left unfilled. If a statutory undertaker requires a filling to be used it shall be a free draining material as described in paragraph 4.4. Where surface or sub-surface water flows towards a bridge from the approaches suitable upstands and drainage outlets shall be provided to prevent water entering the service bays and leaking into expansion joints.

Make-up Materials for Footways, Central Reserves and Verges

4.4 Wherever possible make-up material of either no-fines concrete or other free draining materials or concrete shall be used over the waterproofing. Where loose filling is required it should be a material such as 10mm nominal single size aggregate rather than sand. Sub-surface drainage shall be provided.

Drainage Systems

4.5 Systems for the drainage of water from bridges shall be so detailed that water is not allowed to fall freely from the bridge deck. Closed drainage systems shall be provided, and these systems shall be fully provided with facilities for rodding and other necessary maintenance. It is essential that drainage systems are sufficiently robust to withstand damage during cleaning,

5. DETAILING OF DECK WATERPROOFING

5.1 The waterproofing shall be continuous and cover the entire deck between parapet upstands including footways, central reserves, verges, service bays and under kerbs (see Detail 1). On bridges with separate superstructures each deck shall be waterproofed independently. Particular attention is to be paid to sealing the waterproofing membrane at its edges and around interruptions such as gulleys.

5.2 Sharp arrises and internal angles should be avoided in the deck surface to be waterproofed. Arrises should be chamfered or rounded and fillets formed in internal angles. Chases into which sheet waterproofing membranes are tucked should have the lower face splayed (see Detail 1).

Deck Movement Joints

5.3 At all movement joints in the deck the waterproofing shall be detailed in such a way to prevent water percolating beneath the waterproofing membrane.

5.4 At sealed joints, it is essential that the waterproofing membrane, the relevant parts of the joint and any sealing material form a continuous impervious barrier. Impervious materials, eg epoxy resin mortar, are to be bonded directly to the deck.

5.5 The detailing of waterproofing at deck movement joints including buried joints is given in BD 33 (DMRB 2.3.6).

Service Bays

5.6 All service bays shall be waterproofed on sides and floor and the system shall generally be the same as for the deck. Waterproofing on the floor of service bays shall always be protected (see paragraph 9.5). For service bay drainage see paragraph 4.3.

Top Slabs of Buried Structures

5.7 Where the structure is covered with fill such as in the case of underpasses, culverts and cattle creeps etc the top slab shall be waterproofed with a Permitted Waterproofing System. Where the top slab is continuous with the abutments waterproofing on the top surface shall be continued down the outside of the abutment to a

level 200mm below the soffit of the top slab. On top slabs of buried structures protection to the waterproofing system shall be either a bituminous APL or concrete to Clause 2602 of the Specification (MCHW 1) and ST1 mix.

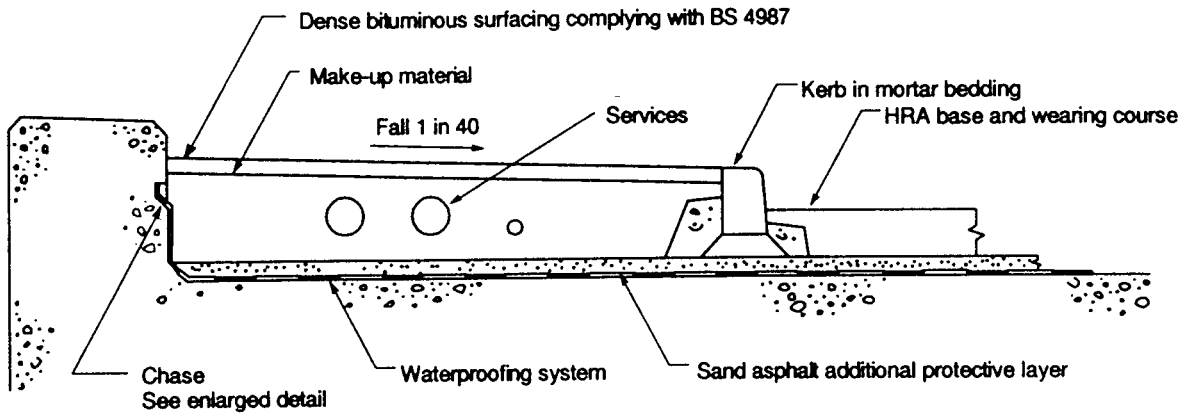

DETAIL 1

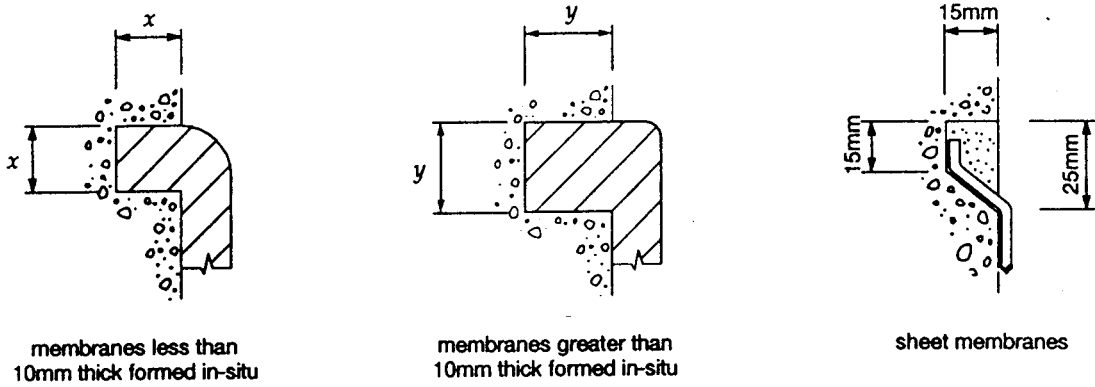

Details of chases

TYPICAL DETAILS OF WATERPROOFING SYSTEMS

6. CONCRETE DECK CONSTRUCTION

Surface Finish

6.1 The required surface finish to new bridge decks between parapet upstands and to top slabs of buried structures is Class U4 in accordance with Clause 1708.4 of the Specification (MCHW 1).

7. WATERPROOFING SYSTEMS

7.1 Procedures to enable the use of waterproofing systems in highway contracts are given in Appendix A of this Standard. Requirements, tests and checks for Permitted Waterproofing Systems are given in Appendix B of this Standard, and requirements for Certification site trials are given in Appendix C.

7.2 The use of a Permitted Waterproofing System on concrete bridge decks and buried top slabs does not prejudice the need to ensure adhesion compatibility with the concrete and the surfacing.

8. INSTALLATION AND WORKMANSHIP

General

8.1 The installation of the waterproofing system shall be in accordance with the Specification (MCHW 1) and the requirements specified in the BBA Roads and Bridges Agrément Certificate for the particular system.

8.2 Uniform adhesion is essential at all interfaces ie concrete/primer/waterproofing membrane/tack coat/additional protective layer/surfacing in order to ensure durability of the concrete deck, waterproofing system and the surfacing. Minimum values for adhesion are given in Appendix B.

8.3 The use of ventilating layers, partial bonding or bond breakers with the waterproofing system shall not be permitted.

8.4 All waterproofing systems shall be terminated in a chase. Where a prefabricated membrane is terminated in a chase, the rebate shall be filled with a compatible sealant (see Chapter 5, Detail 1). Where a liquid applied membrane is terminated in a chase, the membrane shall be taken into the chase, but a sealant is not required.

Blisters and Pin/Blow holes

8.5 It is essential that all defects in waterproofing systems such as blisters and pin/blow holes are made good before any subsequent layers/coats are applied.

8.6 Details for making good of defects are included in the BBA Roads and Bridges Agrément Certificate and the method statement for the particular waterproofing system.

9. PROTECTION OF WATERPROOFING

9.1 The protection of bridge deck waterproofing during construction shall be in accordance with Clause 2002 of the Specification (MCHW 1).

9.2 Protective layers forming part of a waterproofing system shall be incorporated over the whole of the deck area to be waterproofed.

9.3 The APL 20mm nominal thickness shall be laid on all waterproofed bridge deck areas to protect the waterproofing during subsequent construction operations. Waterproofed vertical faces eg upstands and the sides of service bays do not require an APL, and for the floor of service bays alternative materials may be used.

9.4 In specific instances (either maintenance or new works) where there are limitations on the total thickness of the asphaltic material above the waterproofing system, the requirement for the APL may be relaxed and the Overseeing Organisation shall be consulted for advice on the choice of suitable waterproofing systems and application made to the TAA for a departure from Standards to cover this non-standard aspect. In such cases, waterproofing systems meeting the requirements of the Aggregate Indentation Test at 125°C (paragraph B4.2.(i)) shall be considered suitable.

Service Bays

9.5 Waterproofing on the floor of service bays shall receive additional protection with one of the following:

- i) 20mm of sand asphalt protection.
- ii) 50mm thick screed of concrete to Clause 2602 of the Specification (MCHW 1) and ST1 mix.
- iii) Approved tiles hand set in bitumen.

10. SURFACING ON CARRIAGEWAYS

10.1 Except for accommodation bridges, on both flexible and rigid pavement roads the bridge decks shall be surfaced with bituminous materials complying with Series 900, Road Pavements - Bituminous Bound Materials, in the Specification (MCHW 1). Accommodation bridges may be treated similarly or may be surfaced with concrete.

10.2 For new works the designed total minimum thickness of surfacing material shall generally be 100mm excluding the waterproofing system and APL. For maintenance works the total minimum thickness may be determined by existing circumstances.

Bridge Deck Expansion Joints

10.3 Special consideration shall be given to the detail at deck expansion joints where the surfacing thickness may be locally reduced by the design of the deck joint.

Bonding of APL or Surfacing to the Waterproofing System

10.4 The APL or surfacing laid on the waterproofing system shall be uniformly bonded to the system with a compatible tack coat. Where a tack coat for the APL or surfacing is not required as part of the waterproofing system a uniform bond to the membrane shall be obtained from the binder within the directly applied APL or surfacing. Minimum bond values are given in Appendix B.

11. SURFACING ON FOOTWAYS, CENTRAL RESERVES AND VERGES

11.1 The surfaces of footways, central reserves and verges shall be laid to falls so that surface water will be shed into the drainage system.

11.2 Surfacing may be flexible, rigid or formed with paving flags. Flexible surfacing shall be dense bituminous surfacing complying with BS 4987 or mastic asphalt complying with BS 1447.

11.3 Where any make up material is free draining a dense surfacing shall be used. The surfacing may be applied directly to a stable make up material such as concrete or no-fines concrete. Where mastic asphalt surfacing complying with BS 1447 is to be used on no-fines concrete it shall first have been sealed with a sand-cement slurry. In Scotland only air entrained structural concrete complying with Clause 4.4 shall be used as make up material.

11.4 Where the make up material is a loose filling a suitable base course shall be used before the flexible surfacing is applied.

12. REFERENCES

1 Design Manual for Roads and Bridges

Volume 2: Section 2: Special Structures

BD 12 Corrugated Steel Buried Structures
(DMRB 2.2.6)

Volume 2: Section 3: Materials and Components

BD 33 Expansion Joints for Use in Highway
Bridge Decks (DMRB 2.3.6)

BA 47 Waterproofing and Surfacing of
Concrete Bridge Decks (DMRB 2.3.5)

2 Manual of Contract Documents for Highway Works

Volume 0: Section 3: Advice Notes

SA1 Lists of Approved/Registered Products
(MCHW 0.3.1)

Volume 1: Specification for Highway Works
(MCHW 1)

Volume 2: Notes for Guidance on the
Specification for Highway Works (MCHW 2)

3 British Standards

BS 1447: 1988: Mastic asphalt (limestone fine
aggregate) for roads, footways and paving in
buildings.

BS 4987: 1988: Coated macadam for roads and
other paved areas.

4 Technical Memorandum (Bridges)

BE 27 - Waterproofing and Surfacing of Bridge
Decks.

5 Statutes

Health and Safety at Work Act 1974.

Health and Safety at Work (Northern Ireland)
Order 1978.

Control of Substances Hazardous to Health
Regulations 1989.

Control of Substances Hazardous to Health
Regulations (Northern Ireland) 1990.

Factories Act 1961.

Factories Act (Northern Ireland) 1965.

13. ENQUIRIES

All technical enquiries or comments on this Standard should be sent in writing as appropriate to:

Chief Highway Engineer
The Highways Agency
St Christopher House
Southwark Street
London SE1 0TE

J KERMAN
Chief Highway Engineer

Director, Road Network Management
and Maintenance Division
The Scottish Executive Development Department
Victoria Quay
Edinburgh EH6 6QQ

N B MACKENZIE
Director, Road Network Management
and Maintenance Division

The Director of Highways
The National Assembly for Wales
Cynulliad Cenedlaethol Cymru
Crown Buildings
Cathays Park
Cardiff CF1 3NQ

K J THOMAS
Director of Highways

Director of Engineering
Department of the Environment for
Northern Ireland
Roads Service Headquarters
Clarence Court
10-18 Adelaide Street
Belfast BT2 8GB

V CRAWFORD
Director of Engineering

PROCEDURES TO ENABLE THE USE OF WATERPROOFING SYSTEMS IN HIGHWAY CONTRACTS

A1. A waterproofing system is permitted for use in trunk road works provided that

- (a) It has a BBA Roads and Bridges Agrément Certificate showing compliance with current HA requirements (see Appendix B) and
- (b) The Permitted Waterproofing System (PWS) is registered with the Overseeing Organisation and
- (c) The Overseeing Organisation has not suspended use of the system.

A2. It is for the manufacturer or their representative to obtain a BBA Roads and Bridges Agrément Certificate for their particular system.

A3. To be awarded a BBA Roads and Bridges Agrément Certificate the waterproofing system is subjected to laboratory testing and checking for compliance with HA requirements by BBA or a BBA/HA approved Test Laboratory. The laboratory results are assessed by BBA and if acceptable the system is subjected to a site trial on an actual bridge deck.

A4. Detailed requirements for the site trial are given in Appendix C.

A5. When the assessment by BBA of both the laboratory testing and checking and the site trial show the system to be acceptable BBA award a Roads and Bridges Agrément Certificate and the system is permitted for use in trunk road works.

A6. If at some subsequent time the system shows itself to be unsatisfactory by failing to maintain its Certification requirements, the Overseeing Organisation reserve the right to suspend or remove permission for the system to be used in trunk road works notwithstanding the validity of the BBA Roads and Bridges Agrément Certificate.

CERTIFICATION TEST REQUIREMENTS FOR WATERPROOFING SYSTEMS ON CONCRETE BRIDGE DECKS

B1. INTRODUCTION

B1.1 This Appendix gives a series of test requirements for the Certification of waterproofing systems for concrete bridge decks. The Certification procedure has been designed so that the manufacturer or their representative has the option of withdrawing from the test programme at various stages if the British Board of Agrément (BBA) finds the system submitted fails to comply with the requirements.

B1.2 The HA reserves the right to amend or supplement the tests required for BBA Certification. The costs of additional tests will be the responsibility of the manufacturer or their representative.

B1.3 Certification shall be given only if the waterproofing system successfully passes the complete test programme and site trial. The HA reserves the right to suspend or remove permission for the systems to be used in highway works for the Overseeing Organisations, and to withdraw Departmental Registration for any system which fails to maintain the test requirements in service.

B2. PROCEDURE

The procedure for Certification is divided into the following stages:

- i) Application for assessment
- ii) Provision of unbonded membranes for testing
- iii) Provision of systems bonded to concrete for testing
- iv) Provision of a site trial on an actual bridge deck.

The manufacturer may withdraw from the remainder of the test programme at the completion of any of these stages.

B2.1 Application for Assessment

Manufacturers requiring a waterproofing system to be assessed shall submit the following basic details of their waterproofing system to the BBA.

For All Systems:

System name
Description of Materials
Storage requirements
Installation Method Statement
Repair techniques
On site integrity testing by non-destructive testing (NDT) method(s)
Expected Service Life
Health and Safety Data Sheets

Where Applicable:

Concrete surface preparation
Type of primer
Type of adhesive and application temperature
Number of layers/coats
Type of protection
Type of tack coat for bituminous overlay
Minimum activation temperature of system or tack coat
Other details

Additional information required for:

Sheet and Board Systems

Dimensions
Weight
Handling temperatures

Liquid Applied Systems

Mixing time of components
Pot life of mixed liquid materials
Nominal coverage rates
Setting time
Cured/dry density
Mix details
Dry film minimum/maximum thickness (Note. HA requirement for 2mm minimum thickness: see paragraph C12)

B2.2 Unbonded (As Received) Membranes

It is necessary for samples of unbonded sheets, boards and cured/dry film of liquid applied membranes (prepared by the manufacturer or their representative in the presence of the BBA) to be submitted for the test programme.

The following sample sizes are required.

- Sheet systems - Minimum 3 standard rolls
- Board systems - Minimum to cover 5 square metres
- Liquid applied systems - Free film to cover 5 square metres minimum size (1 x 1)m

In addition, following a successful outcome to checks and basic tests by the BBA (B3.1 and B3.2), membranes/systems bonded to concrete (prepared by the manufacturer or their representative in the presence of the BBA) will be required for B3.3 and B4.2.

B2.3 Preparation of Bonded Systems**Preparation of Concrete Test Blocks**

Three sizes of concrete test blocks are to be used for the bonded membrane tests.

- (A) (170 x 170 x 55)mm
- (B) (300 x 300 x 55)mm
- (C) (400 x 220 x 55)mm with crack inducer - see Fig 1

The tolerance on block dimensions shall be ± 3 mm.

Portland Cement to BS 12 shall be used with mix proportions by weight 1 : 2 : 3.5 (cement : sand : aggregate) using 20mm gravel aggregate for Blocks A and B and 10mm gravel aggregate for Blocks C in accordance with BS 882 and having a water: cement ratio of 0.5 maximum. The surface to which the membrane is to be bonded shall have a U4 finish in accordance with Clause 1708 of the Specification for Highway Works (MCHW 1).

All blocks shall be cured and thoroughly dry before use. A suitable curing regime is:

Demould after 24 hours.

Store under wet hessian and polythene sheet at normal ambient room conditions for 6 days.
Store uncovered at normal ambient room conditions for at least 21 days.

With BBA in attendance samples of the waterproofing membrane/system are to be bonded to the blocks by the manufacturer or their representative.

The following minimum number of blocks are required to test one waterproofing system:

- 72 size (A) blocks
- 12 size (B) blocks
- 9 size (C) blocks with crack inducers

For systems using a separate bonding agent (eg those using oxidised bitumen adhesive or similar), the adhesive is to be omitted from a central circular area of 120mm diameter for selected tests (see B3). This is in order that the system may be tested without the influence of the adhesive. For this requirement size (A) blocks shall be used. The system is bonded around the periphery only of the block, leaving the central area unbonded. This requirement will normally apply to selected sheet systems and is referred to in paragraph B4.2(d).

B2.4 Site Trial

Following the successful results of the laboratory test programme (see B3) the manufacturer or their representative is then required to undertake a site trial (see Appendix C).

B3. TEST PROGRAMME

The programme of tests and checks is sub-divided as follows (Test Methods are given in B4.):

B3.1 Identification and Quality Control

Identification and quality control tests are to be defined by the BBA for the purpose of checking manufacturers' submitted data (see B2.1). These control tests will not form part of the Certification but the BBA will advise the manufacturer on the suitability of the submitted system for continuing with the Certification testing.

The manufacturer may withdraw at this stage.

B3.2 Tests on Unbonded Sheets, Boards and Film of Liquid Applied Membranes (As Received From Manufacturer)

Dimensional checks	
For sheets and boards	For films
(a) Straightness (b) Width (c) Thickness	(d) Thickness

The thickness of prefabricated sheet and board samples submitted for examination and testing shall comply with the nominal thickness intended with a tolerance of $\pm 10\%$.

For all systems:

- Weight per unit area
- Water absorption
- Resistance to water penetration including penetration through joints etc.
- Resistance to damage
- Change in flexibility
- Dimensional stability

Handling tests
(a) Unrolling of sheet materials (complete rolls) (b) Unrolling sheet materials off a mandrel (c) Tests on boards

For sheet and board materials:

- Resistance to tear
- Ability to lay flat
- Ease of cutting and preparation

For sheet materials only:

- Resistance to recoil
- Resistance to edge curl
- Ability to bend through 90°
- Ability to be tapped to 90° corner

Failure to meet any of the test requirements may result in the BBA refusing Certification or placing limitations on use.

The manufacturer shall be advised and may withdraw from the remainder of the test programme.

B3.3 Tests on Waterproofing Membranes/Systems Bonded to Concrete

These tests shall be applied to all systems.

(a) Tests and Checks During Installation:

- i) Nominal coverage rates of all liquid components of the system.
- ii) Setting time of all liquid components of the system under the recorded conditions of installation including temperature and humidity.
- iii) Resistance to pin/blow holing (principally liquid applied membranes).
- iv) Effects of moisture on setting time (liquid applied membranes).

(b) Tests After Installation

- i) Tensile adhesion test (tat)
- ii) Resistance to chloride ion penetration (cip)
- iii) Resistance to freeze thaw +(cip) and (tat)
- iv) Resistance to heat ageing +(cip) and (tat)
- v) Resistance to chisel impact +(cip)
- vi) Resistance to aggregate indentation +(cip)
- vii) Resistance to thermal shock, heat ageing and crack cycling +(cip)
- viii) Surfacing to waterproofing system interface shear adhesion test
- ix) Surfacing to waterproofing system interface tensile bond test.

(c) Failure to meet any of the test requirements of this stage may result in the BBA refusing Certification or placing limitations on use.

The manufacturer shall be advised and may withdraw from the remainder of the test programme.

(d) A copy of the test report shall be lodged by the BBA with the HA who in consultation with the BBA will confirm whether the assessment may proceed to the site trial.

B3.4 Site Trial Checks and Tests

Prior to installation of the waterproofing system the BBA shall verify:

- i) the suitability and condition of the bridge deck for the site trial including any preparation necessary.
- ii) the quality assurance statement of all materials forming the waterproofing system.

During the installation of the waterproofing system and the asphalt surfacing the BBA shall record the following as applicable:

Age of concrete
Installation temperature of the system
Relative humidity
Weather conditions
Nominal coverage rates
Setting time
Thickness applied
Pin/blow holing/blistering
Bond of the membrane to the concrete bridge deck
In situ integrity NDT method(s)
Repair procedure
Workmanship and supervision
Damage to system prior to asphalt surfacing
Temperature of asphalt applied
Damage caused by asphalt surfacing
Bond of the asphalt surfacing to the system

B4. TEST METHODS

For all tests where the temperatures are $(-10 \pm 2)^\circ\text{C}$, $(+23 \pm 2)^\circ\text{C}$ and $(+40 \pm 2)^\circ\text{C}$ respectively the RH at 23°C shall be $(50 \pm 5)\%$ and the actual RH at the other temperatures shall be recorded.

B4.1 Tests on Unbonded Sheets, Boards and Film of Liquid Applied Membranes (where applicable)**(a) Dimensional Checks**

- i) Straightness of sheets and boards

Sheets shall be unrolled over a 10m length (or the length of the roll if less) and boards laid flat along a straight edge at an ambient temperature of $(23 \pm 2)^\circ\text{C}$. The deviation from the straight edge to be no more than $\pm 10\text{mm}$ in any 2m length.

- ii) Width of sheets and boards

Width shall be measured to an accuracy of 1.0mm at 10 evenly spaced intervals along the full length of the sheet or board. This shall remain uniform within $\pm 10\text{mm}$ from the nominal.

- iii) Thickness

Thickness shall be measured to an accuracy of 0.01mm using a micrometer or dial gauge with an 8mm diameter circular foot loaded to exert a pressure of $0.02\text{N}/\text{mm}^2$. 60 measurements shall be made on specimens taken over the whole area. For mineral dressed sheets measurements shall also be made along the seldge. For sheets and boards measurements are over the full length and width at regular intervals and for cured liquid applied membranes over the central (1 x 1)m, ignoring the edge perimeter width of at least 50mm. For sheets and boards the thickness at any location shall be within $\pm 10\%$ of the nominal thickness.

(b) Weight per Unit Area

A minimum of three specimens (150 x 150)mm each weighed to an accuracy of 0.01 grammes.

(c) Water Absorption

The specimens used for weight measurement shall be immersed in a water bath for 28 days at $(23 \pm 2)^\circ\text{C}$ and then re-weighed after removing the surface water. The increase in weight shall not exceed 7%.

Specimens which exceed this limit shall be subjected to freezing for 24 hours at $(-10 \pm 2)^\circ\text{C}$. After the freeze period the specimen shall be conditioned for at least 4 hours at $(23 \pm 2)^\circ\text{C}$ and then observed under a minimum of x20 magnification for damage or thickness change.

When compared with a control specimen there shall be no damage and for sheets and boards any change in thickness shall be limited to $\pm 10\%$ of the control thickness.

(d) Resistance to Water Penetration

Three specimens of membrane, (250 x 250)mm, are subjected to a water pressure of 0.6 atmospheres over a diameter of 150mm at a test temperature of $(23 \pm 2)^\circ\text{C}$. Specimens consisting of maximum 100mm overlaps, and where appropriate butt joints are also tested. The specimens shall be fully supported by a metal gauze sheet. There shall be no water penetration after 28 days.

(e) **Handling Tests**

The following are basically qualitative tests to give initial indication of suitability.

Rolls of Sheet Membranes

Complying with the manufacturer's storage conditions rolls of sheet membranes are placed in a temperature controlled cabinet at $(-10 \pm 2)^{\circ}\text{C}$, $(23 \pm 2)^{\circ}\text{C}$ and $(40 \pm 2)^{\circ}\text{C}$ respectively for 24 hours. The manufacturer may declare a reduced temperature range for handling but this shall include 4°C to 30°C and the range limits shall be tested. The membranes are then unrolled immediately on removal from the cabinet.

The following requirements shall apply:

- i) No edge damage to roll during storage
- ii) One man operation to unroll
- iii) Minimal increase in stiffness of the sheet
- iv) Membrane shall lay flat without damage or rucking
- v) No cracking in the membrane on unrolling
- vi) Recoil shall not exceed 2.5m over a length of 10m
- vii) Edge curl shall not exceed a height of 50mm in 150mm
- viii) Deviation from the straight edge shall be limited to 10mm in any 2m length.

Unrolling Sheet Membranes from a Mandrel

Three longitudinal and three transverse specimens (450 x 50)mm are cut from the roll, wound onto a 25mm diameter mandrel and secured with tape.

These are then placed in a temperature controlled cabinet at $(-10 \pm 2)^{\circ}\text{C}$, $(23 \pm 2)^{\circ}\text{C}$ and $(40 \pm 2)^{\circ}\text{C}$ respectively for 24 hours. They are then unwound slowly at the stored temperature.

The following tests shall be conducted:

One end is bent through 90° and the other end is tapped gently to a 90° corner.

The ease of cutting is checked using a razor edged knife.

The following requirements shall apply:

- i) A minimal increase in the stiffness with no embrittlement.
- ii) No damage, cracking, permanent set or dimensional instability.
- iii) Membrane easily cut to shape with minimal contamination of cutting blade.
- iv) Good resistance to tearing under normal handling.

Board Materials

Specimens and sizes prepared similarly to those for unrolling sheet membranes from a mandrel but laid flat in a cabinet under the same temperature conditions.

The flexibility, damage and tendency for dimensional instability are checked as above.

The tear and ease of cutting are checked for boards as above.

If the handling tests are unsatisfactory at the minimum and maximum temperatures, intermediate temperatures may need to be included. The membrane shall be rejected if there is an unsatisfactory performance between 4°C and 30°C .

Membranes not conforming to the full range but satisfactory at the reduced range shall have these limits quoted on the Certificate.

B4.2 Tests on Waterproofing Systems Bonded to Concrete

(a) Resistance to Pin/Blow Holing (principally liquid applied membranes)

Four size (B) concrete blocks are used for this test.

Two size (B) blocks are immersed in water for a minimum of 24 hours, removed and the surface allowed to dry in still air for up to two hours at $(23 \pm 2)^{\circ}\text{C}$. The sealer/primer and waterproofing membrane is applied according to the manufacturer's requirements to all four blocks as one or two coats. The samples are observed after two hours for pin/blow holes or blisters. Temperature and RH should be recorded during the test.

There shall be no blisters and not more than four pin/blow holes continuous or non-continuous within a central area of (250 x 250)mm for both samples. The

size of any pin/blow hole present shall be recorded and no pin/blow hole shall exceed 1mm in diameter. The requirement for pin/blow holing applies to single-coat, two or more coat membranes.

Where single coat membranes do not meet the above requirements the manufacturer shall be given the opportunity of applying the membrane as two or more coats to the same total thickness. If then acceptable the system shall be used as a two or more coat membrane and the remainder of the tests shall be as for a two or more coat membrane.

(b) Setting of a Liquid Applied Membrane on a Concrete Block with a High Moisture Content

During the pin/blow holing test the setting time of the membrane on the four blocks is also noted. The nominal value for the membrane on the wetted blocks shall be within $\pm 10\%$ of the nominal setting time on the dry blocks, unless the manufacturer specifies differently. If this applies then the time shall accord with the manufacturer's declared limits.

(c) Nominal Coverage Rates of all Liquid Components of the System

During preparation of the samples, nominal coverage rates will be confirmed by the manufacturer or their representative.

(d) Tensile Adhesion Test

Bond of waterproofing membrane to concrete substrate.

Nine size (A) concrete blocks with membranes fully bonded are to be used for this test ie 3 blocks for each test temperature. On each block, an area of membrane, (100 x 100)mm, is isolated by cutting down to the concrete without disturbance to the membrane. A steel plate, (100 x 100 x 10)mm is bonded to this area with a suitable adhesive. A tensile pull off apparatus that locates onto the surface of the plate is used (eg Figure 2). The loading shall be applied progressively at a rate of (0.4 ± 0.2) kN/sec. The test shall be carried out in temperature controlled conditions at $(-10 \pm 2)^\circ\text{C}$, $(23 \pm 2)^\circ\text{C}$ and $(40 \pm 2)^\circ\text{C}$ respectively. The test samples shall have been preconditioned at the above temperatures for at least 2 hours.

The stress at failure for each individual sample shall be not less than:

0.3 N/mm² at $(-10 \pm 2)^\circ\text{C}$ and $(23 \pm 2)^\circ\text{C}$ respectively, and
0.2 N/mm² at $(40 \pm 2)^\circ\text{C}$.

(e) Resistance to Chloride Ion Penetration

Three size (A) concrete blocks are to be used for this test [B3.3(b)(ii)].

For membranes where a separate adhesive is used, the samples for testing for cip alone, together with chisel impact with cip [B3.3(b) (ii) and (v)], shall be unbonded in the central circular 120mm diameter area (see preparation of concrete test blocks B2.3). For all other combined cip tests [B3.3(b)(iii), (iv), (vi) and (vii)], the membranes shall be fully bonded.

Note: For 3.3(b)(iv) size (B) block is required.
For 3.3(b)(vii) size (C) block is required.

A glass vessel, 100mm diameter (Figure 3) is sealed with a silicone or similar suitable adhesive to the surface of the membrane. For mineral dressed membranes the dressing may need to be modified or removed in the area of the seal to ensure adequate sealing.

The vessel is filled with 1.47 litres of saturated sodium chloride solution which makes contact with the membrane surface. The test is conducted at $(23 \pm 2)^\circ\text{C}$ over a period of 28 days. Water penetration or absorption is detected by a fall in the level of the liquid.

Observations of surface sweating and wicking of salt solution along an interface are made periodically. The solution, vessel and membrane are then removed.

A sample of powdered concrete is taken from the surface of the concrete block using the profile grinding technique. The sample shall be obtained by grinding the surface of the concrete to a depth of 3mm. Approximately 40 grams of dust shall be collected.

Two representative specimens, approximately 5 grams each, are taken from the sampled dust and analysed for chloride ion concentration. The average value of the two results obtained from the analysis shall represent the chloride ion concentration for each block.

Salt penetration is determined by measuring the percentage of chloride ions present in the powdered concrete sample. Ion selective electrode method shall be used.

The following requirements shall be met after 28 days.

- i) The maximum increase in chloride ion concentration in the concrete shall be not more than 0.04%.
- ii) The maximum loss in volume of the liquid in the test vessel shall be less than 20ml.

- iii) There shall not be any significant surface sweating.
- iv) There shall not be any significant inter-laminar salt penetration.
- v) There shall not be any deterioration or debonding of the membrane from the concrete.

(f) Resistance to Freeze-Thaw

Six size (A) concrete blocks with the membrane bonded are to be used for this test. Three of the blocks with membrane fully bonded are used for water absorption/freeze-thaw/tensile adhesion B4.2(d) tests and three blocks with the membrane fully bonded but partially bonded for membranes using a separate adhesive (see B2.3) are for the water absorption/freeze-thaw/chloride ion penetration (B4.2(e)) test. The six samples are subjected to water absorption (using deionised water) for 28 days at $(23 \pm 2)^{\circ}\text{C}$ using a 100mm diameter vessel and pipe coupling as shown in Figure 4.

Membranes exhibiting up to 7% water absorption determined in B4.1(c) shall be subjected to 6 freeze-thaw cycles. Membranes exhibiting more than 7% water absorption (see paragraph B4.1(c)) shall be subjected to 20 freeze-thaw cycles. Each cycle shall consist of 8 hours freeze at $(-10 \pm 2)^{\circ}\text{C}$ and 16 hours thaw at $(23 \pm 2)^{\circ}\text{C}$. During the thawing period water is introduced into the pipe coupling collar to a depth of approximately 50mm. The water is then removed before commencing the freeze cycle. On completion of the freeze-thaw cycling the samples are conditioned for at least 24 hours at $(23 \pm 2)^{\circ}\text{C}$. Three samples are then subjected to the tensile adhesion test (B4.2(d)) and the remaining three samples to the chloride ion test (B4.4(e)). The requirements for both these tests shall apply at $(23 \pm 2)^{\circ}\text{C}$.

If there is severe loss of salt solution but no increase in chloride ion concentration in the concrete, further investigation shall be made by the BBA.

(g) Resistance to Heat Ageing

Six size (A) concrete blocks with the membrane fully bonded are to be used for the two aspects of this test.

All samples are placed in a ventilated oven and maintained at $(70 \pm 3)^{\circ}\text{C}$ for 28 days. These are then conditioned for at least 24 hours at $(23 \pm 2)^{\circ}\text{C}$. Three samples are subjected to the chloride ion test (B4.2(e)) and the remaining three samples are subjected to the tensile adhesion test (B4.2(d)). The requirements for both these tests shall apply at $(23 \pm 2)^{\circ}\text{C}$.

(h) Resistance to Chisel Impact

The membrane bonded to nine size (A) blocks (prepared in accordance with B2.3 and B4.2(e)) are to be used for this test, ie 3 blocks for each test temperature. The test shall be carried out in temperature controlled conditions at $(-10 \pm 2)^{\circ}\text{C}$, $(23 \pm 2)^{\circ}\text{C}$, and $(40 \pm 2)^{\circ}\text{C}$ respectively. The chisel impact apparatus and the test specimen shall be preconditioned at the respective temperatures for at least 2 hours.

A chisel head 20mm wide with a 90° tip angle and weighing 1.0kg is dropped from a height of 200mm directly onto the central test area of the membrane. The chisel is guided through a linear bearing inside a tube of low thermal conductivity (Figure 5). Five impacts are made within an area delineated by a circle of 75mm diameter.

The chloride ion test (B4.2(e)) at $(23 \pm 2)^{\circ}\text{C}$ shall then be applied. If one of the three samples indicates an unacceptable increase in chloride ion concentration or significantly high solution volume loss, the test shall be repeated on a further three samples and all of these specimens are required to pass the test.

(i) Resistance to Aggregate Indentation

Systems (excluding any tack coat) with an overall thickness of 20mm or greater are exempted from this test.

The tests are conducted at $(40 \pm 2)^{\circ}\text{C}$, $(80 \pm 3)^{\circ}\text{C}$ and $(125 \pm 3)^{\circ}\text{C}$.

Nine size (A) concrete blocks with the system fully bonded (excluding any tack coat) are to be used for these tests, ie 3 blocks for each test temperature.

Each concrete block is first measured within the central 75mm diameter test area at 4 separate locations using a template (Figure 6) with a dial gauge. The system is then fully bonded and the block re-measured at the same 4 locations using the template and the dial gauge.

The system thickness is calculated by subtracting the measured concrete block thickness from the total thickness. The mean thickness of the system is calculated from the four results. For sheet and board systems the thickness shall comply within $\pm 10\%$ of the declared nominal thickness.

Aggregate Indentation Test at 40°C

All systems shall be subjected to aggregate indentation at $(40 \pm 2)^\circ\text{C}$. This is to simulate the compaction of loose aggregates into the system during normal site activities prior to the APL being applied.

Aggregate indentation is simulated by a steel indenter in the shape of a truncated cone. The cone angle is 90° , the diameter at the truncation 8mm and the diameter at the base not less than 25mm. Indentation is produced by forcing the truncated end into the system using a test machine that measures force and displacement simultaneously. The indenter is electrically heated to a temperature of $(40 \pm 2)^\circ\text{C}$ and the samples shall have been preconditioned for at least 4 hours at $(40 \pm 2)^\circ\text{C}$. The test is conducted at a temperature of $(40 \pm 2)^\circ\text{C}$ checked by a probe or thermocouple (Figure 7).

Indentations are made in the same 4 locations as the thickness measurements. Each indentation is made by driving the indenter into the system at a rate of 5mm/minute. Indentation is stopped when the force applied reaches 1000N. The load is removed at the same rate. The sample is then conditioned for a minimum of 24 hours at $(23 \pm 2)^\circ\text{C}$ to allow the system to recover.

The overall thickness is then measured at the same 4 locations using the template and the dial gauge. Individual thickness measurements are then determined by subtracting the concrete block thickness from the overall thickness.

Indentation after the recovery period shall not exceed 50% of the initial thickness of the system.

The chloride ion test (B4.2(e)) at $(23 \pm 2)^\circ\text{C}$ shall then be applied.

Aggregate Indentation Test at 80°C

This test including the chloride ion test (B4.2(e)) at $(23 \pm 2)^\circ\text{C}$ is the same as that at $(40 \pm 2)^\circ\text{C}$ except that the temperature of the indenter is $(80 \pm 3)^\circ\text{C}$ and the indenter is stopped when the force reaches 500N.

Aggregate Indentation Test at 125°C

This test shall be carried out unless the manufacturer indicates that the system is not suitable to be tested at $(125 \pm 3)^\circ\text{C}$.

The indenter, number of indentations, application loads and procedure are the same as for the test at $(40 \pm 2)^\circ\text{C}$

except that the preconditioning temperature shall be $(50 \pm 3)^\circ\text{C}$.

The temperature controlled cabinet is maintained at $(50 \pm 3)^\circ\text{C}$. The indenter is electrically heated to a constant $(125 \pm 3)^\circ\text{C}$.

The requirements for indentation and chloride ion test (B4.2(e)) at $(23 \pm 2)^\circ\text{C}$ remain as for the test at $(40 \pm 2)^\circ\text{C}$.

If the system fails to meet these criteria at $(125 \pm 3)^\circ\text{C}$ but is satisfactory at $(80 \pm 3)^\circ\text{C}$ and $(40 \pm 2)^\circ\text{C}$ then APL shall always be applied. (Also see paragraph 9.4 for relaxation of APL).

(j) Thermal Shock, Heat Ageing and Crack Cycling

Nine size (C) concrete blocks with the membrane fully bonded are to be used for this test, ie 3 blocks for each test temperature. See Figure 1 for extent of membrane application. For liquid applied membranes the concrete block shall be masked over length ways, 40mm either side before applying the membrane.

The sample is first subjected to a thermal shock to simulate the application of hot surfacing, and then heat ageing followed by crack cycling.

i) Thermal Shock

A wooden box with no base, having a wall thickness of 50mm, a height of 55mm and internal plan of (170 x 170)mm is placed on the membrane in the centre of the test block over the area where the crack cycling test is to be made. A thermocouple or similar is placed on the surface of the membrane within the box and the temperature progressively recorded. Aluminium foil (thin gauge) is laid on the membrane and lines the inside of the box.

A suitable heat source, such as liquid bitumen or hot sand is poured into the box and sealed in to give a temperature of $(145 \pm 5)^\circ\text{C}$ on the surface of the membrane. Due to heat loss the initial temperature of the heated material is to be approximately 240°C . After two hours the heat source is removed and the sample conditioned at $(23 \pm 2)^\circ\text{C}$ for at least 4 hours.

If necessary where the membrane incorporates a protective layer, this may be removed to permit examination of the membrane proper for cracks.

ii) Heat Ageing

The samples are placed in a ventilated oven and maintained at $(70 \pm 3)^\circ\text{C}$ for 28 days. These are then conditioned for 24 hours at $(23 \pm 2)^\circ\text{C}$.

iii) Crack Cycling

Crack cycling is conducted at $(-10 \pm 2)^\circ\text{C}$, $(23 \pm 2)^\circ\text{C}$ and $(40 \pm 2)^\circ\text{C}$ respectively after the recovery period of the heat ageing test.

Initial cracking of the sample at the crack inducer (Figure 1) is made using a suitable crack cycling apparatus (Figure 8). Cracking is induced at $(23 \pm 2)^\circ\text{C}$ and the crack width is limited to 1.0mm. The sample is then cycled at a rate of 1 cycle/second to the maximum crack width at one of the above temperatures and subjected to a total of 100 cycles. On completion the crack is maintained at maximum opening for 24 hours at the test temperature.

There shall be no visually obvious cracks in the membrane proper at any stage during the test.

After conditioning the test sample for a minimum of 24 hours at $(23 \pm 2)^\circ\text{C}$ the chloride ion test (B4.2(e)) at $(23 \pm 2)^\circ\text{C}$ shall be applied.

The complete test is repeated for each of the above temperatures.

(k) Surfacing to Waterproofing System Interface Shear Adhesion Test

This test is conducted at $(-10 \pm 2)^\circ\text{C}$, $(23 \pm 2)^\circ\text{C}$ and $(40 \pm 2)^\circ\text{C}$. Fifteen size (A) concrete blocks ie 5 blocks for each test temperature are used with the system fully bonded together with any tack coat specified for the system.

Samples are prepared with an overlay of sand asphalt and/or hot rolled asphalt using mixtures as specified in BS 594: Part 1, the rolling temperature being within the range specified in BS 594: Part 2 but not exceeding the maximum values given in Clause 901.9 of the Specification (MCHW 1), and in particular

i) where a minimum rolling temperature to achieve bond to the system is declared, this shall be applied

or ii) where a tack coat forms part of the system the rolling temperature shall be the minimum temperature declared to activate the tack coat.

The sand asphalt and hot rolled asphalt shall be prepared as and when required in compliance with BS 594: Part 1. Reheated material shall not be used.

For samples overlaid with sand asphalt, it shall be compacted to a nominal thickness of 20 mm and the total overlay thickness made up with hot rolled asphalt laid and compacted to a finished total nominal thickness of 50mm. Sand asphalt shall comply with BS 594: Part 1, recipe Type F wearing course mixture Designation 0/3 except that $(5 \pm 0.5)\%$ of the total mix shall be inorganic red oxide and regarded as part of the filler content. The make-up of the hot rolled asphalt shall comply with BS 594: Part 1, Table 2, Column 2/1.

For samples overlaid with hot rolled asphalt only it shall comply with BS 594: Part 1: Table 2, Column 2/1, and be laid and compacted to a nominal thickness of 50mm.

The binder throughout shall be 50 pen bitumen complying with BS 3690: Part 1. The coarse aggregate shall comply with BS 594: Part 1, Clause 2.2, Group (a) granite and the sand fine aggregate with Clause 2.3.

The test samples shall have been pre-conditioned at $(-10 \pm 2)^\circ\text{C}$, $(23 \pm 2)^\circ\text{C}$ and $(40 \pm 2)^\circ\text{C}$ for at least 4 hours and then supported in a test frame (Figure 9). This complete apparatus is placed in a temperature controlled cabinet and maintained at one of the test temperatures.

A shearing force shall be applied to the sand asphalt and/or hot rolled asphalt via a steel loading plate at the rate of 20mm/minute; the load and deformation characteristics being continuously recorded. The test shall be continued until the sample fails. The assembly is then removed, the failure interface and peak force noted and failure stress determined. The stress at failure for each individual sample shall be not less than

0.2N/mm² at $(-10 \pm 2)^\circ\text{C}$ and $(23 \pm 2)^\circ\text{C}$ respectively, and 0.1N/mm² at $(40 \pm 2)^\circ\text{C}$.

(l) Surfacing to Waterproofing System Interface Tensile Bond Test

Four size (B) concrete blocks are to be used with the system fully bonded together with any tack coat specified for the system.

Specimens are prepared with an overlay of sand asphalt or hot rolled asphalt using a mixture as specified in BS 594: Part 1, the rolling temperature being within the range specified in BS 594 : Part 2 but not exceeding the maximum values given in Clause 901.9 of the Specification (MCHW 1), and in particular

- i) where a minimum rolling temperature to achieve bond to the system is declared, this shall be applied
- or ii) where a tack coat forms part of the system the rolling temperature shall be the minimum temperature declared to activate the tack coat.

The sand asphalt and hot rolled asphalt shall be prepared as and when required in compliance with BS 594: Part 1. Reheated material shall not be used.

For samples overlaid with sand asphalt, it shall be laid and compacted to a nominal thickness of 20mm and comply with BS 594: Part 1 recipe Type F wearing course mixture Designation 0/3 except that $(5 \pm 0.5)\%$ of the total mix shall be inorganic red oxide and regarded as part of the filler content.

For samples overlaid with hot rolled asphalt, it shall comply with BS 594: Part 1, Table 2, Column 2/1, and be laid and compacted to a nominal thickness of 50mm.

The binder throughout shall be 50 pen bitumen complying with BS 3690: Part 1. The coarse aggregate shall comply with BS 594: Part 1, Clause 2.2, Group (a) granite and the sand fine aggregate with Clause 2.3.

On each sample two test areas (100 x 100)mm are isolated by cutting down to the concrete without disturbance to the complete system. Steel plates are bonded to the test areas with a suitable adhesive (see Fig 10).

The test shall be carried out at $(23 \pm 2)^\circ\text{C}$ on a tensile testing machine with a crosshead speed of 20mm/minute. The test samples shall have been preconditioned at $(23 \pm 2)^\circ\text{C}$ for at least 4 hours. Bond failure at the interface of the system and the sand asphalt or hot rolled asphalt shall be not less than $0.1\text{N}/\text{mm}^2$ for each specimen.

B4.3 Site Trial

- (a) Procedures and requirements for the site trial are given in Appendix C
- (b) The site trial shall be formally assessed by the BBA. The HA reserve the right to attend any site trial.

B5. REFERENCES

The following documents are referred to in this Appendix B.

B5.1 Manual of Contract Documents for Highway Works

Volume 1: Specification for Highway Works (MCHW 1).

B5.2 British Standards

BS 12: 1989 Specification for Portland cements.

BS 882: 1992 Specification for aggregates from natural sources for concrete.

BS 594: Part 1: 1992 Hot rolled asphalt for roads and other paved areas. Specification for constituent materials and asphalt mixtures.

BS 594: Part 2: 1992 Hot rolled asphalt for roads and other paved areas. Specification for the transport, laying and compaction of rolled asphalt.

BS 3690: Part 1: 1989 Bitumens for building and civil engineering. Specification for bitumens and for roads and other paved areas.

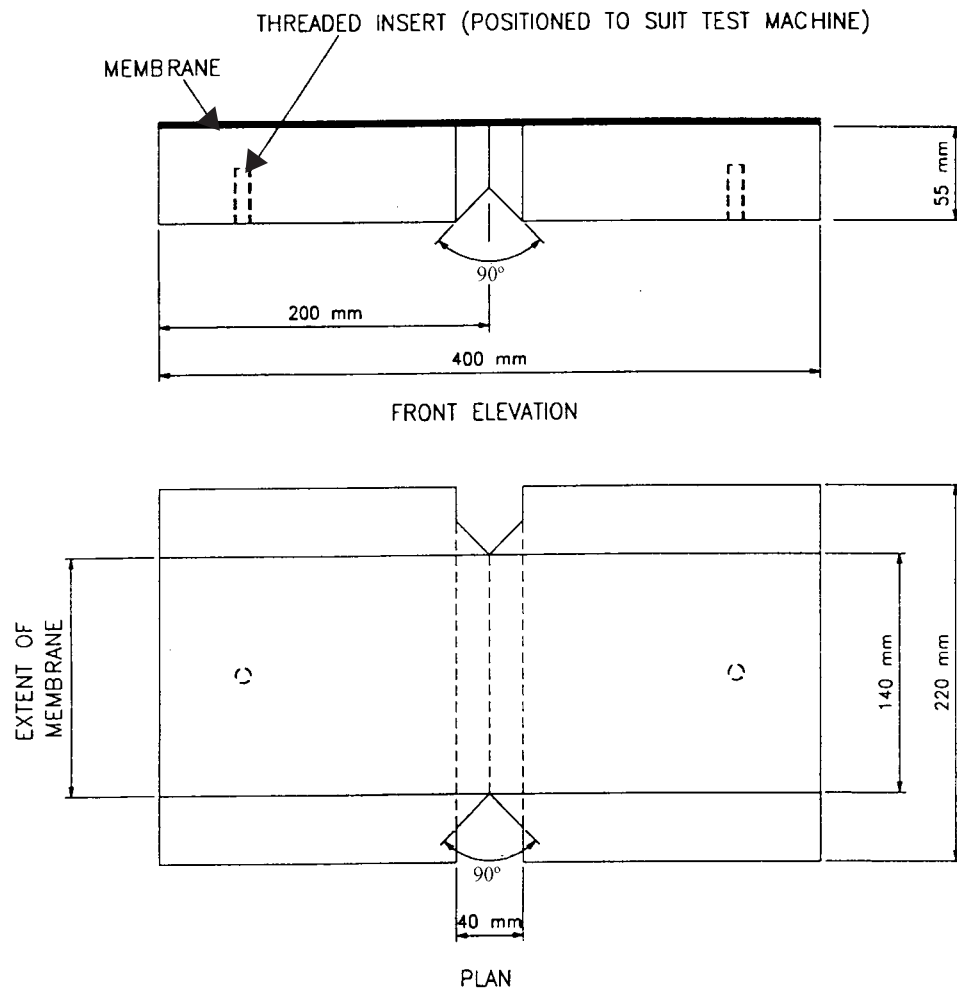

**FIGURE 1 CONCRETE TEST BLOCK WITH CRACK INDUCER
(SCALE 1:4 APPROX) ALL DIMENSIONS ARE IN mm**

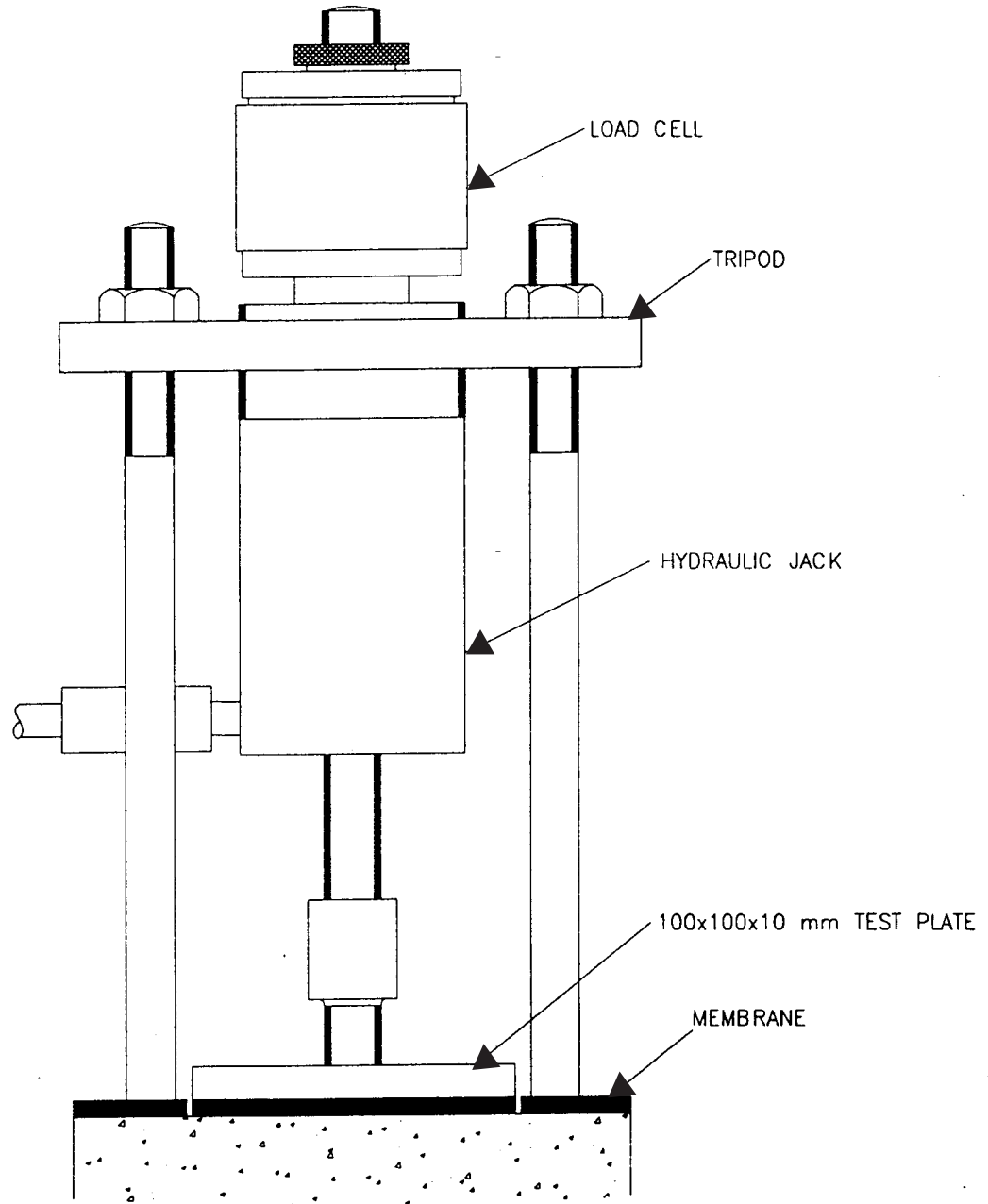
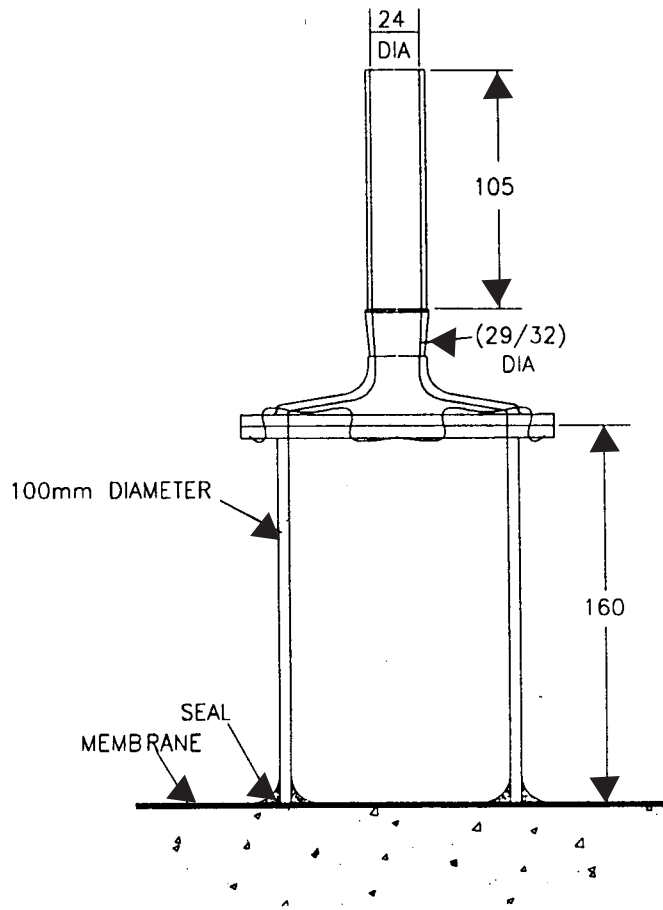
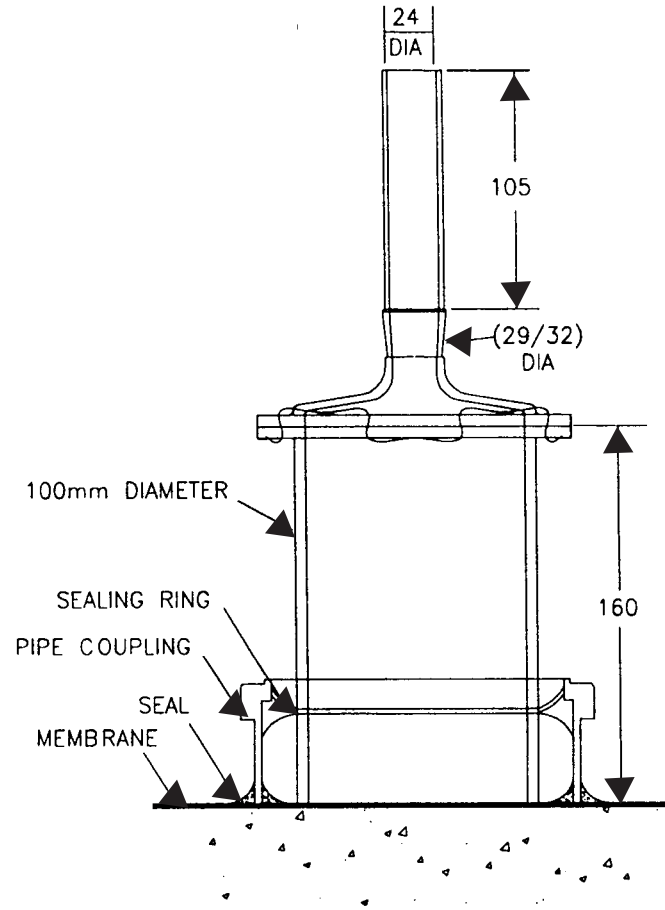

FIGURE 2 EXAMPLE OF A TENSILE PULL-OFF (SCALE: HALF FULL SIZE)



**FIGURE 3 CHLORIDE ION PENETRATION TEST
(SCALE 1:3 APPROX)
ALL DIMENSIONS ARE IN mm**



**FIGURE 4 EXPOSURE TO WATER OR
CHLORIDE IONS GLASSWARE
(SCALE 1:3 APPROX)
ALL DIMENSIONS ARE IN mm**

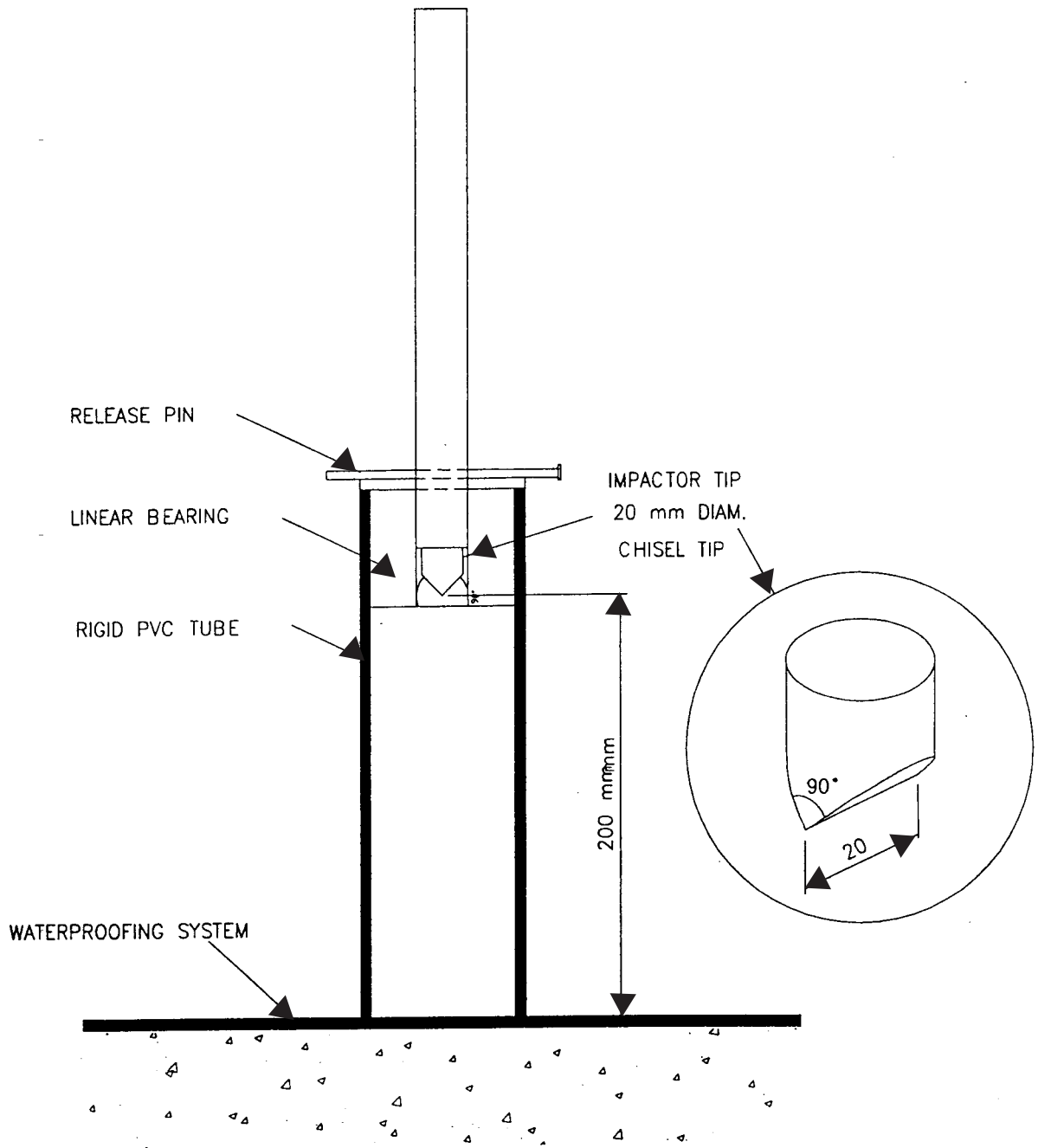
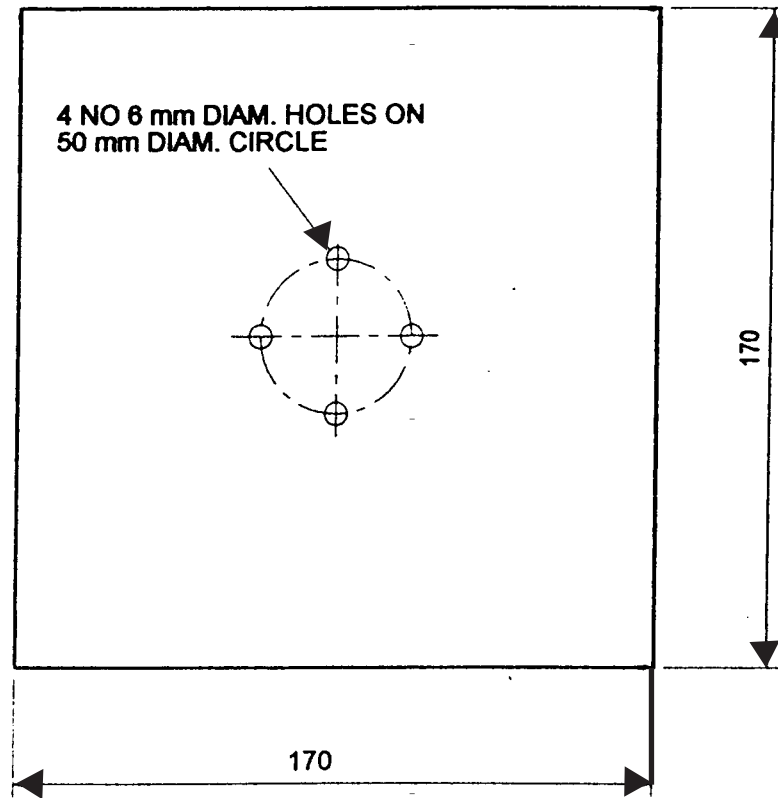

FIGURE 5 CHISEL IMPACT APPARATUS (SCALE: 1:3 APPROX)



**FIGURE 6 AGGREGATE INDENTATION TEST TEMPLATE
(SCALE HALF FULL SIZE) ALL DIMENSIONS ARE IN mm**

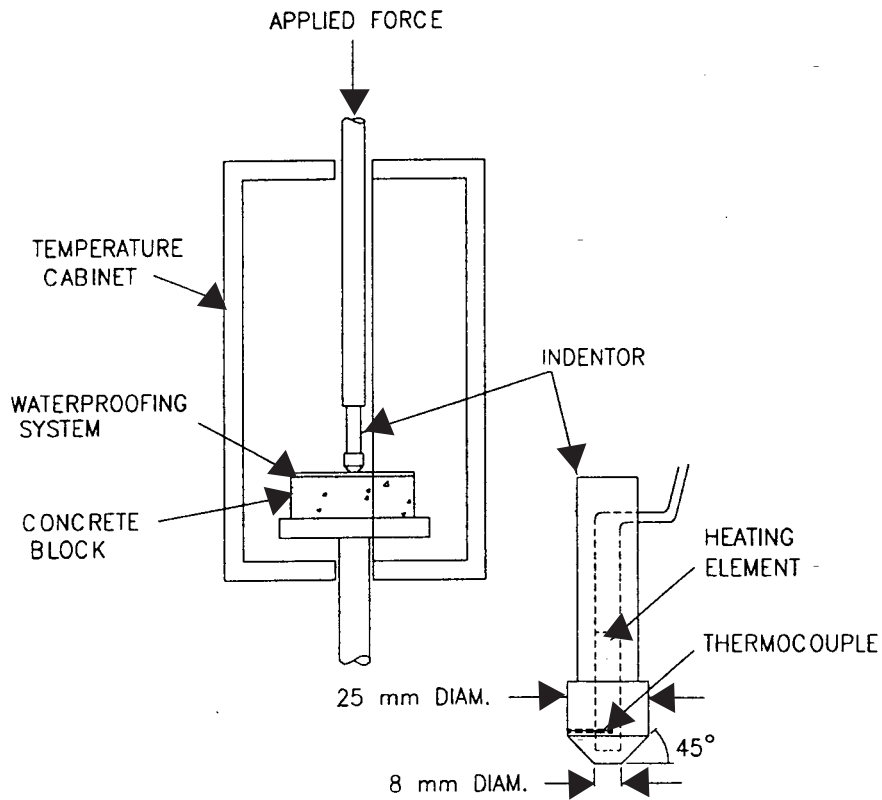

FIGURE 7 AGGREGATE INDENTATION TEST (SCALES 1:10 & 1:2 APPROX)

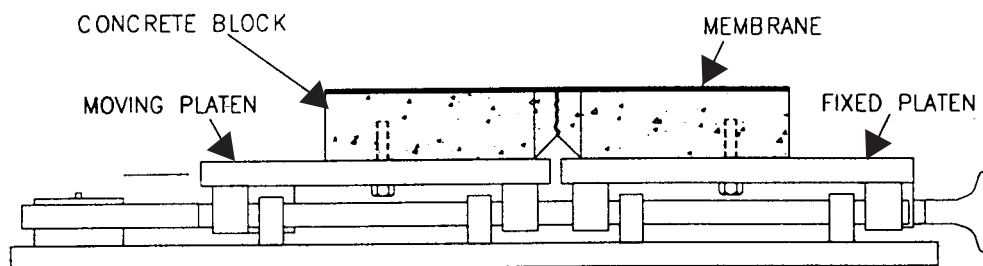

FIGURE 8 CRACK CYCLING APPARATUS (SCALE 1:6 APPROX)

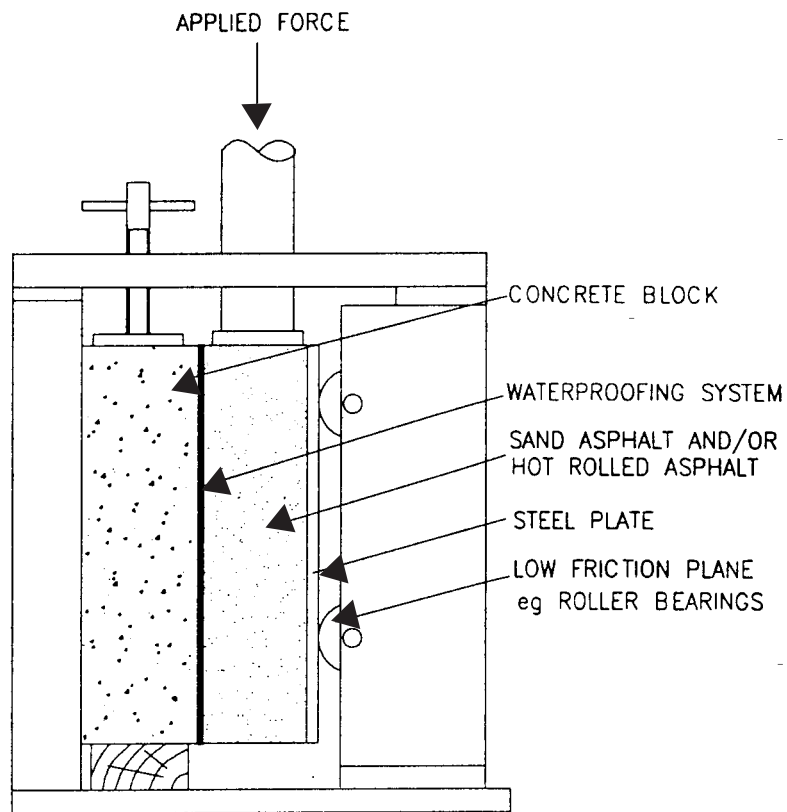

FIGURE 9 SHEAR ADHESION APPARATUS (SCALE 1:3 APPROX)

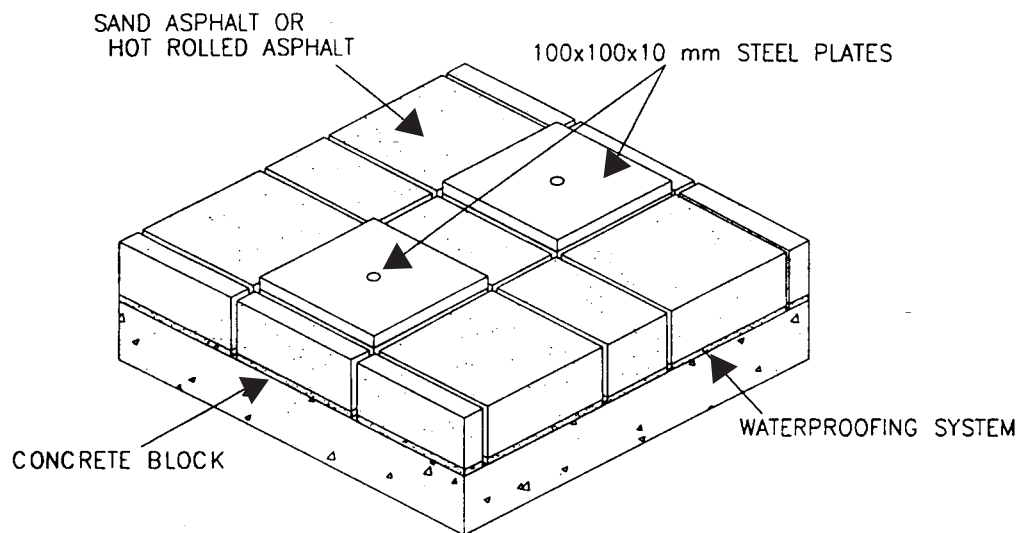

FIGURE 10 PREPARED SAMPLE FOR CHECK OF INTERFACE TENSILE BOND

PROCEDURES AND REQUIREMENTS FOR CERTIFICATION SITE TRIALS FOR PERMITTED WATERPROOFING SYSTEMS (PWS)

Part of the requirements for the award of a BBA Roads and Bridges Agrément Certificate for a PWS is a successful site trial on an actual bridge deck. This can take place only after the laboratory tests and checks have been successfully completed by the BBA. It is then for the manufacturer or their representative of the PWS to arrange for the system to be installed on a suitable bridge.

In arranging the site trial the manufacturer or their representative shall take into account the following procedures and requirements.

C1. Where a bridge is being considered for the site trial the bridge owner or highway authority shall consider the importance of the bridge location (ie not on a strategic route), when giving agreement in principle to the installation of a waterproofing system undergoing a Certification site trial.

C2. The BBA shall be sent a general arrangement drawing of the bridge showing the size and type of deck including a cross section showing details of the waterproofing system. A minimum deck area of 150 square metres is necessary and the bridge shall include some features such as parapet upstands, service bays, chases and fillets. Also required are details of

- (a) Bridge name, location and bridge owner/highway authority.
- (b) Whether the bridge is of new construction or in the course of maintenance.
- (c) Surfacing type, thickness and size and type of aggregate when not given on the drawing.
- (d) Additional protective layer ie sand asphalt to be applied to the system.
- (e) Make-up of deck concrete ie proportion of cement replacements and other additives in the concrete.
- (f) Concrete curing method.
- (g) Proposed dates of installation of the system and surfacing. When this is not known then the likely dates which can be confirmed as the programme progresses.

C3. Where the BBA confirms that the bridge is acceptable for the site trial the manufacturer or their representative may pursue arrangements with the highway authority and the Contractor and shall advise them that the site trial will be formally assessed by the BBA. HA reserve the right to attend the site trial.

C4. The site trial shall be performed in a workmanlike manner by trained operatives under competent supervision and shall afford the level of quality of workmanship required for the Certification.

C5. In addition to the BBA Roads and Bridges Agrément Certification requirements the works shall comply with the Specification for Highway Works (MCHW1).

C6. The site trial shall include observation of the preparation of the concrete deck, the installation of the waterproofing system and the surfacing. The performance of the system between its installation and prior to overlaying with the surfacing shall also be monitored.

C7. On arrival at the trial site the BBA shall inspect the condition of the concrete deck. This shall be U4 finish but the manufacturer or their representative may opt to apply the system on a deck with a lesser finish in consultation with the BBA. In such a case the system will be expected to perform as though the finish was U4. The deck surface shall be clean, dry and free from ice, frost and laitance etc as given in Clause 2001 of the Specification (MCHW 1).

C8. Before any part of the waterproofing system is installed the BBA shall verify that the system is as that submitted for the laboratory tests.

C9. Discrepancies that arise with respect to either site conditions or changes to the waterproofing system shall be agreed with the BBA before the site trial can proceed.

C10. On site the concrete surface and air temperature shall be measured by the manufacturer or their representative using thermocouples or similar. This shall be checked frequently over the period of the site trial. The relative humidity shall also be noted at the same time.

C11. The nominal coverage rates and setting times of the liquid components of the system shall accord with the manufacturer's specification. Checks shall be made for ponding of primers and any ponding that has occurred shall be minimal.

C12. During and after installation of the system the following requirements shall apply:

- i) The hot bitumen adhesives for sheet systems shall not be greater than 240°C measured using a suitable temperature probe by the manufacturer or their representative.
- ii) The thickness of liquid membranes shall be a minimum of 2mm over peaks, arrises and irregularities in the concrete deck and shall be checked with a wet film thickness gauge or other appropriate method by the manufacture or their representative.
- iii) There shall be appropriate bond to the concrete substrate checked by the manufacturer or their representative and it shall be virtually free from visible defects including pin/blow holes and blisters which shall be made good by repair before being covered.
- iv) Sheet and board systems shall be laid to follow the contours of the deck surface and be free from ripples and rucks.
- v) Laps in sheet systems shall comply with Clause 2005.6 of the Specification (MCHW 1). Butt joints in board systems shall be formed in accordance with the manufacturer's instructions.
- vi) The manufacturer or their representative laying the waterproofing system at the site trial shall demonstrate to the BBA an acceptable repair method.
- vii) The manufacturer or their representative shall demonstrate the integrity of the waterproofing membrane by an appropriate NDT method agreed with the BBA.

C13. The waterproofing system shall be checked for damage before applying the APL or asphalt surfacing. Where damage has occurred it shall be suitably repaired before the trial proceeds.

C14. In order to dispense with the requirement of the APL for waterproofing systems which are less than 20mm thick and which have complied with the 125°C

aggregate indentation test in the laboratory, Clauses C13 to C22 inclusive shall apply except that the APL shall be replaced with asphalt surfacing.

C15 The placing temperature of the APL or asphalt surfacing, measured with a suitable temperature probe by the manufacturer or their representative shall not exceed 145°C. The minimum rolling temperature of the APL or asphalt surfacing shall not be less than that specified in BS 594 Part 2 or less than the minimum declared activation temperature for bond to the system, whichever is greater.

C16. Prior to the completion of the APL or asphalt surfacing laying on site, the compacted but still hot APL or asphalt surfacing is removed from a sample area of the system and any damage to the waterproofing membrane is observed.

C17 If damage has occurred restrictions on any further application of the surfacing may be imposed and the damaged waterproofing membrane shall be repaired or replaced.

C18. Where no damage occurs the cut back areas are then filled with new APL or asphalt surfacing and compacted.

C19. Throughout the site trial, workmanship, supervision and general site procedure will be observed by the BBA. Where this is at an unacceptably low standard, Certification shall not be granted.

C20. Where the system is deemed to have failed the site trial, the Contractor shall be instructed to remove the failed system from the bridge and dispose off-site. The bridge shall then be waterproofed with a registered system.

C21. If during the site trial it is considered that the system is unlikely to proceed to a successful conclusion, then the manufacturer or their representative may be given an opportunity to abort the site trial and propose modifications to the system/procedures to be considered for a further trial. The manufacturer or their representative shall provide a written report to the BBA with proposed changes that would overcome identified deficiencies in the original submission. If the proposed modifications are acceptable to the BBA the manufacturer or their representative will be allowed to make arrangements for a further site trial.

C22. Notwithstanding Clause C21, the bridge owner/highway authority reserve the right to have the bridge waterproofed with a registered system.